

Supplemental Information & Instructions

for

453-618 Rack & Pinion Assembly with Installation Kit

453-619 Rack & Pinion Assembly

453-628 Installation kit, Rack & Pinion

MGB 63-74½ RD to (c)360300, GT to (c)361000 (Chrome Bumper)

(For Rack & Pinion Installation in a Rubber Bumper MGB, see page 5 of 7)

Safety Warning

Proper installation of the MGB steering rack is a safety critical procedure. Improperly installed, the steering will be stiff, which may make it difficult to control the car. In some cases the loading on the steering shaft will be so great that it will fail. If this occurs while the vehicle is in motion, the result may be an accident with the potential for serious or fatal injury. If you have the slightest doubt about your ability to complete this procedure, you should have the installation done by a competent mechanic who understands the importance of following the procedure.

Background

The same rack and pinion was fitted to US spec MGBs from 1962 to 1974 ½. The rack changed when the MGB went from chrome to rubber bumpers. The steering column changed from a solid shaft to an energy absorbing column in 1967. The installation and alignment procedures are significantly different and are covered in separate sections to avoid confusion. Because the alignment is so critical, Moss has reproduced the factory alignment tools so that the factory procedure can be followed. We developed these instructions based on the original factory workshop manual, adding information and rearranging some of the material for clarity.

Parts Reference

Ref	Part#	Description	Qty
	453-618	Rack & Pinion Assembly, with Installation kit	1
		<i>Which Consists of</i>	
10	453-619	Rack & Pinion Assembly	1
11	-	Steering shaft	1
	453-628	Installation Kit	1
		<i>Which Consists of</i>	
20	453-622	Alignment Tool, Rack & Pinion	1
22	263-130	Shim, rack adjusting	5
		<i>The rest of these parts are listed for clarity, but are not included in any kit.</i>	
12	263-090	U-Joint Assembly	1
13	17H3839	Pinch bolt, U-joint	2
14	365-730	Lock washer, 5/16	2
15	310-140	Nut, 5/16 UNF	2
16	BH605161	BOLT 5/16 UNF X 2IN	2
17	365-720	Lock washer, 5/16, rear	2
18	365-720	Flat washer, 5/16	4
19	320-585	BOLT 5/16UNF X 2-1/4	2
21	365-720	Flat washer, 5/16	2
23	-	Rivet, shim to crossmember	2
24	365-720	Flat washer, 5/16	2
25	310-290	Nut,nyloc, front, 5/16 unf	2

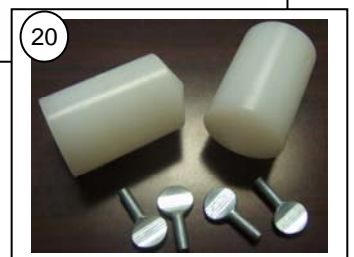
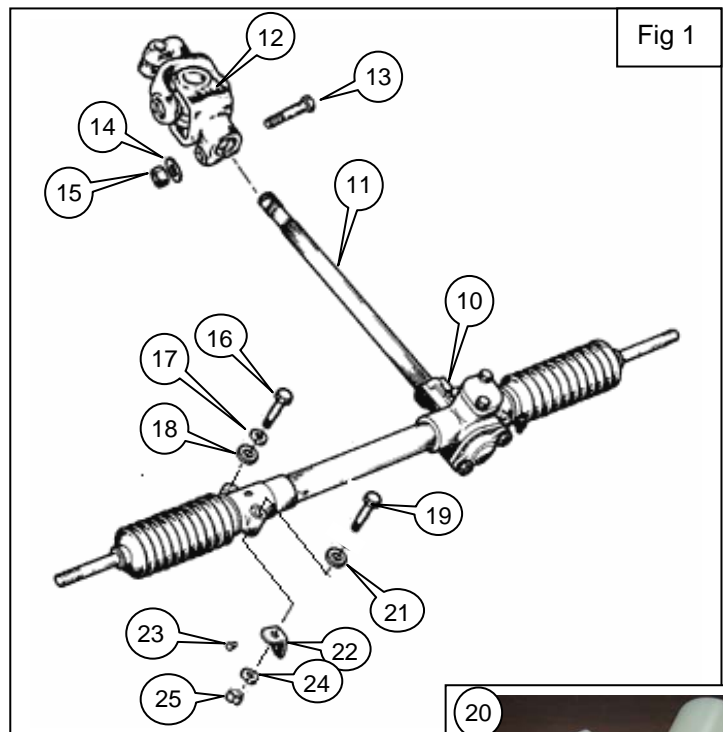

26 **Before You Begin**

27 *These instructions do not replace the factory workshop manual, which you will need to remove the existing rack*
28 *and pinion from the vehicle properly. The manual also contains information on the steering column not contained in*
29 *these instructions. If you do not have a workshop manual, get one. As with all instructions, read through this*
30 *document completely and make sure you understand what you are going to do before you pick up a tool.*

31 **Steering Shaft Alignment Instructions, MGB 1963-67 (without the energy**
32 **absorbing column)**

33 ***When assembling the steering-column or steering gearbox assembly to the car care must be taken to***
34 ***ensure that universal joint is free (no binding) before the column or steering rack securing bolts are***
35 ***tightened. For the universal joint to be completely unloaded the centre-line of the steering-column and***
36 ***the centre-line of the steering shaft must pass through the centre of the universal joint spider when***
37 ***the assembly is viewed from above and from the side. Failure to ensure complete freedom at the***
38 ***universal joint will load the steering pinion upper bearing and cause extreme wear and steering***
39 ***stiffness.***

- 40
- 41 1) Block the rear tires, and support the front of the car on a pair of jack stands on a level hard surface.
42 Observe all normal shop safety procedures.
 - 43 2) Set the steering in the straight-ahead position and check that the turn signal cancellation stud at the top of
44 the column is in the correct angular position when the serrations on the coupling and column are aligned.
 - 45 3) Loosen the steering column. Loosen the bolts retaining the steering-column upper and lower support clamp
46 brackets.
 - 47 4) To obtain the proper alignment of the steering shaft, the steering-column support bracket and plate may be
48 moved up and down and sideways and packing shims (Fig 1, 22) may be fitted between the steering rack
49 mounting bosses and the brackets on the front cross member.
 - 50 5) Tighten the universal joint clamp bolts.
 - 51 6) With all column and rack securing bolts loose (Fig 1, 16, 19), position the universal joint and tighten the
52 support bracket clamp bolts at the lower end of the column.
 - 53 7) Look very carefully at the steering rack where it rests on the mounting plates on the crossmember. If there
54 is a gap between the steering rack bosses and mounting brackets on the crossmember, remove the bolts
55 (Fig 1, 16, 19), pack with shims (Fig 1, 22) as required, and replace the rack securing bolts.
 - 56 8) Tighten each rack securing bolt one full turn at a time while your assistant turns the steering wheel from
57 lock to lock. Tighten each bolt one turn, then move to the next one as the steering wheel is being cycled
58 from lock to lock. When the person turning the wheel feels resistance in the steering, stop tightening the
59 bolts. Another shim is needed. Remove the bolt, insert another shim and continue the process. *John Twist*
60 *of University Motors, who suggested this technique, also suggests the use of 5/6" flat washers that have*
61 *been slotted so you don't have to remove the bolt completely to insert a shim. We are grateful to John for*
62 *his input.*
 - 63 9) To ensure complete alignment again slacken and retighten the steering-column lower support bolt.
 - 64 10) Tighten the upper support bracket bolt.

65
66 *To finish the installation of the rack, you will need to install the tie rod ends and finally, you will need to have the*
67 *front end aligned. For guidance on these procedures, please refer to your workshop manual.*

Steering Shaft Alignment Instructions, MGB 1967-74 1/2 (with the energy absorbing column)

- 1) Block the rear tires, and support the front of the car on a pair of jack stands on a level hard surface. Observe all normal shop safety procedures.
- 2) Verify that there is at least one packing washer between each of the 2 top column fixing flanges and the body brackets. (4B)
- 3) Loosen the two top fixing bolts (4B) until the packing washers are just pinched. Remove the third bolt (4A) entirely.
- 4) Check that the column is free to move forwards, backwards and sideways.
- 5) Loosen the three toe-plate fixings bolts, leaving them hand tight. (Fig 5, 5A)
- 6) Check that the lower end of the column is free to move and position it centrally in the opening in the firewall.
- 7) Fit one of the point gauges of the 453-622 Alignment Tool (substitute for the OE tool 18G1140) on the lower end of the column (6B) Position it so that the retaining thumb screw tightens onto the flat machined in the splines.
- 8) Fit the other point gauge (6C) of the 453-622 Alignment Tool to the steering shaft. Position it so that the retaining screw tightens onto the radial groove machined in the splines.
- 9) Fit the rack assembly and tighten the rack mounting bolts.
- 10) Loosen the screw on the column point gauge (6B) and slide the gauge down until the points of both gauges are on the same plane but **not** overlapping.
- 11) The steering-column and rack assembly are correctly aligned when the gauges meet exactly at their points (6A).
- 12) Correct any horizontal (left-right) misalignment by moving the end of the steering-column.
- 13) If any vertical misalignment exists between the gauge points, proceed as follows:
 - a. Remove the rack mounting bolts (7A)
 - b. Add shims (7B) between the mounting brackets on the crossmember (7C) and the rack to correct the vertical misalignment. *You will generally find there is a stack of shims already riveted to your crossmember. You can bend them back out of the way or bend them forward so the shim is between the rack and the mounts on the crossmember. Additional shims are available from Moss as 263-130, or you may use 5/16 flat washers. If you slot the washers, they can be added without removing the mounting bolts.*
 - c. Refit and tighten the rack mounting bolts.
 - d. Recheck the alignment of the gauge points.
 - e. If the alignment is still unsatisfactory, adjust the shim thickness.
 - f. When correct alignment of the gauge points has been achieved, rivet the shims (7B) to the mounting bracket. *If there are shims already riveted to the bracket, it will be necessary to drill out the existing rivet first, and then rivet all the shims together.*
- 14) Remove the rack assembly.
- 15) Remove the point gauges from the steering shaft and steering column.
- 16) Check that the steering-column is in the straight ahead position, and fit the universal joint on to its splines with the pinch-bolt hole aligned with the machined flat.
- 17) Check that the rack is in the straight-ahead position
- 18) Fit the rack assembly and fully tighten the rack mounting bolts.

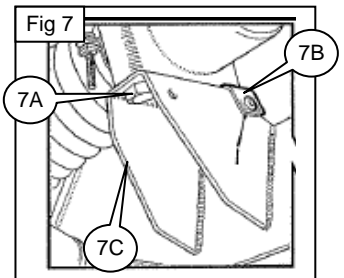
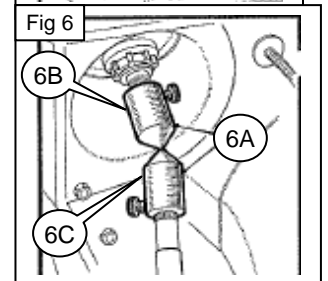
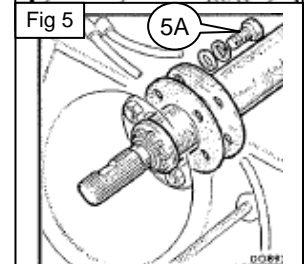
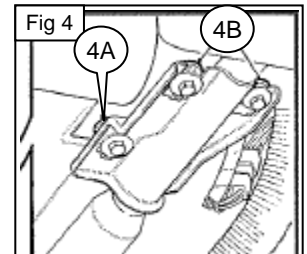

- 125 19) Tighten the three toe-plate to steering-column securing bolts. (Fig 5, 5A)
126 a. Tighten the two steering-column upper fixing bolts (4B). Torque to 12-13 lbs-ft *
127 b. Measure the gap between the column upper mounting flange and the body bracket at the third bolt
128 position (4A). Fit packing washers to the thickness of the gap, then fit and tighten the bolt. Torque
129 to 12-13 lbs-ft.*
130 c. Fit the two universal joint pinch-bolts and tighten them. Torque to 20-22 lbs-ft.*
131

132 *To finish the installation of the rack, you will need to install the tie rod ends and finally, you will need to have the*
133 *front end aligned. For guidance on these procedures, please refer to your workshop manual.*
134

135 **Procedure based on the factory workshop manual, section Ja. Torque specifications taken from the factory*
136 *workshop manual, General Data 18.*
137
138
139
140
141

142
143
144
145
146
147

Supplemental Information & Instructions for 453-638 Rack & Pinion Assembly with Installation Kit 453-627 Rack & Pinion Assembly 453-628 Installation kit, Rack & Pinion MGB 74½ -80 RD from (c)360301, GT from (c)361001

148 Safety Warning

149 **Proper installation of the MGB steering rack is a safety critical procedure. Improperly installed, the steering**
 150 **will be stiff, which may make it difficult to control the car. In some cases the loading on the steering shaft**
 151 **will be so great that it will fail. If this occurs while the vehicle is in motion, the result may be an accident**
 152 **with the potential for serious or fatal injury. If you have the slightest doubt about your ability to complete**
 153 **this procedure, you should have the installation done by a competent mechanic who understands the**
 154 **importance of following the procedure.**

155 Background

156 *The rack and pinion fitted to US spec MGBs changed at 1974 ½ when the MGB went from chrome to rubber*
 157 *bumpers. The energy absorbing column introduced in 1967 was used from 74 ½ through the end of production. The*
 158 *installation and alignment procedures are especially critical on cars with the energy absorbing column. Because the*
 159 *alignment is so critical, Moss has reproduced the factory alignment tools so that the factory procedure can be*
 160 *followed. We developed these instructions based on the original factory workshop manual, adding information and*
 161 *rearranging some of the material for clarity.*

162 Parts Reference

Ref	Part#	Description	Qty
	453-638	Rack & Pinion Assembly, with Installation kit	1
		<i>Which Consists of</i>	
10	453-627	Rack & Pinion Assembly	1
11	-	Steering shaft	1
	453-628	Installation Kit	1
		<i>Which Consists of</i>	
20	453-622	Alignment Tool, Rack & Pinion	1
22	263-130	Shim, rack adjusting	5
		<i>The rest of these parts are listed for clarity, but are not included in any kit.</i>	
12	263-090	U-Joint Assembly	1
13	17H3839	Pinch bolt, U-joint	2
14	365-730	Lock washer, 5/16	2
15	310-140	Nut, 5/16 UNF	2
16	BH605161	BOLT 5/16 UNF X 2IN	2
17	365-720	Lock washer, 5/16, rear	2
18	365-720	Flat washer, 5/16	4
19	320-585	BOLT 5/16UNF X 2-1/4	2
21	365-720	Flat washer, 5/16	2
23	-	Rivet, shim to crossmember	2
24			
25	310-290	Nut,nyloc, front, 5/16 unf	2

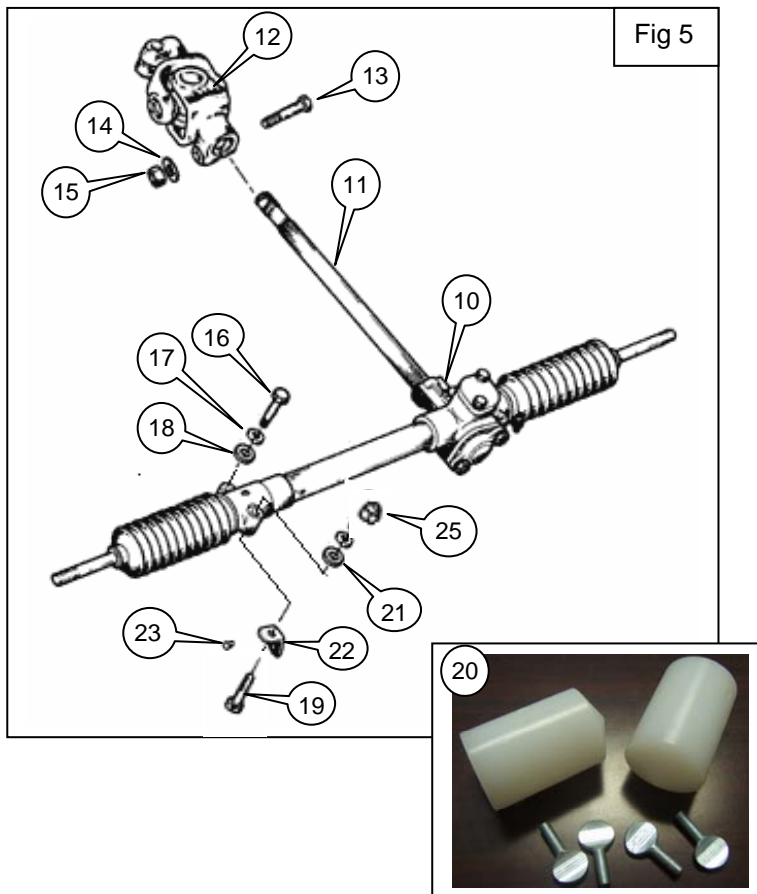

163
164
165

166 **Before You Begin**

167 *These instructions do not replace the factory workshop manual, which you will need to remove the existing rack*
168 *and pinion from the vehicle properly. The manual also contains information on the steering column not contained in*
169 *these instructions. If you do not have a workshop manual, get one. As with all instructions, read through this*
170 *document completely and make sure you understand what you are going to do before you pick up a tool.*
171

172 **Steering Shaft Alignment Instructions, MGB 74 1/2-80 (Rubber Bumper, with**
173 **Energy Absorbing Column)**

174 20) Block the rear tires, and support the front of the car on a pair of jack stands on a
175 level hard surface. Observe all normal shop safety procedures.

176 21) Verify that there is at least one packing washer between each of the 2 top
177 column fixing flanges and the body brackets. (6B)

178
179 22) Loosen the two top fixing bolts (6B) until the packing washers are just pinched.
180 Remove the third bolt (6A) entirely.

181
182 23) Check that the column is free to move forwards, backwards and sideways.

183
184 24) Loosen the three toe-plate fixings bolts, leaving them hand tight. (7A)

185
186
187 25) Check that the lower end of the column is free to move and position it centrally in
188 the opening in the firewall.

189
190 26) Fit one of the point gauges (8B) of the 453-622 Alignment Tool (substitute for the
191 OE tool 18G1140) on the lower end of the column. Position it so that the retaining
192 thumb screw tightens onto the flat machined in the splines.

193 27) Fit the other point gauge (8C) of the 453-622 Alignment Tool to the steering shaft.
194 Position it so that the retaining screw tightens onto the radial groove machined in
195 the splines.

196 28) Fit the rack assembly and tighten the rack mounting bolts.

197 29) Loosen the screw on the column point gauge (8B) and slide the gauge down until
198 the points of both gauges are on the same plane but **not** overlapping.

199 30) The steering-column and rack assembly are correctly aligned when the
200 gauges meet exactly at their points (8A).

201 31) Correct any horizontal (left-right) misalignment by moving the end of the steering-column.

202 32) If any vertical misalignment exists between the gauge points, proceed as
203 follows:

204 a. Remove the rack mounting bolts (9A)

205 b. Add shims (9B) between the mounting brackets on the crossmember
206 (9C) and the rack to correct the vertical misalignment. *You will*
207 *generally find there is a stack of shims already riveted to your*
208 *crossmember. You can bend them back out of the way or bend them*
209 *forward so the shim is between the rack and the mounts on the*
210 *crossmember. Additional shims are available from Moss as 263-130,*
211 *or you may use 5/16 flat washers. If you slot the washers, they can*
212 *be added without removing the mounting bolts.*

213 c. Refit and tighten the rack mounting bolts.

214 d. Recheck the alignment of the gauge points.

215 e. If the alignment is still unsatisfactory, adjust the shim thickness.

216 f. When correct alignment of the gauge points has been achieved, rivet the shims (9B) to the
217 mounting bracket. *If there are shims already riveted to the bracket, it will be necessary to drill out*
218 *the existing rivet first, and then rivet all the shims together.*

219 33) Remove the rack assembly.

220 34) Remove the point gauges from the steering shaft and steering column.

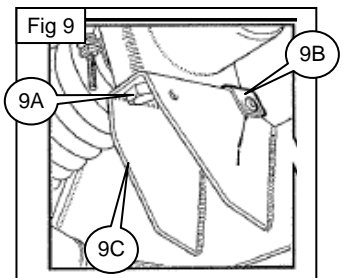
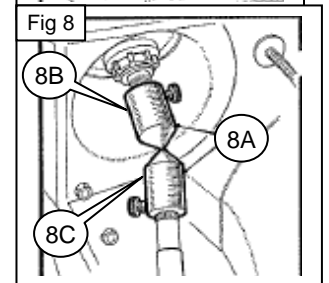
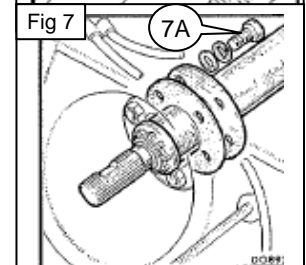
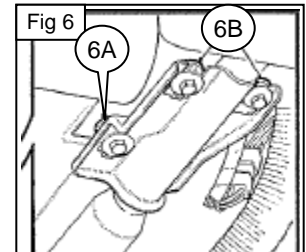

- 221 35) Check that the steering-column is in the straight ahead position, and fit the universal joint on to its splines
- 222 with the pinch-bolt hole aligned with the machined flat.
- 223 36) Check that the rack is in the straight-ahead position
- 224 37) Fit the rack assembly and fully tighten the rack mounting bolts.
- 225 38) Tighten the three toe-plate to steering-column securing bolts. (Fig 5, 5A)
- 226 a. Tighten the two steering-column upper fixing bolts (4B). Torque to 12-13 lbs-ft *
- 227 b. Measure the gap between the column upper mounting flange and the body bracket at the third bolt
- 228 position (4A). Fit packing washers to the thickness of the gap, then fit and tighten the bolt. Torque
- 229 to 12-13 lbs-ft.*
- 230 c. Fit the two universal joint pinch-bolts and tighten them. Torque to 20-22 lbs-ft.*
- 231

232 *To finish the installation of the rack, you will need to install the tie rod ends and finally, you will need to have the*

233 *front end aligned. For guidance on these procedures, please refer to your workshop manual.*

234

235 **Procedure based on the factory workshop manual, section Ja. Torque specifications taken from the factory*

236 *workshop manual, General Data 18.*

237

238

239

240

241

242

243

244

245

246

247

248

249

250

251

252

253

254

255

256

257 *Although we have spent considerable time and effort to ensure that these*

258 *instructions are clear and accurate, it is inevitable that there will be*

259 *corrections or improvements that need to be made. If you have a*

260 *suggestion for a correction or improvement to these instructions, please*

261 *contact our Technical Services Department by phone (805-681-3411) or by*

262 *email using the contact us form on our website.*

263

264

265

266

267

268

269



270 **Moss Motors, Ltd.**

271 440 Rutherford Street, Goleta, California 93117

272 In the US & Canada Toll Free (800) 667-7872 FAX (805) 692-2510 (805) 681-3400

273 **Moss Europe Ltd.**

274 Hampton Farm Industrial Estate, Hampton Road West, Hanworth Middlesex, TW13 6DB

275 In the UK: 020-8867-2020 FAX:- 020-8867-2030