

DECK LUGGAGE RACK ASSEMBLY AND INSTALLATION INSTRUCTIONS

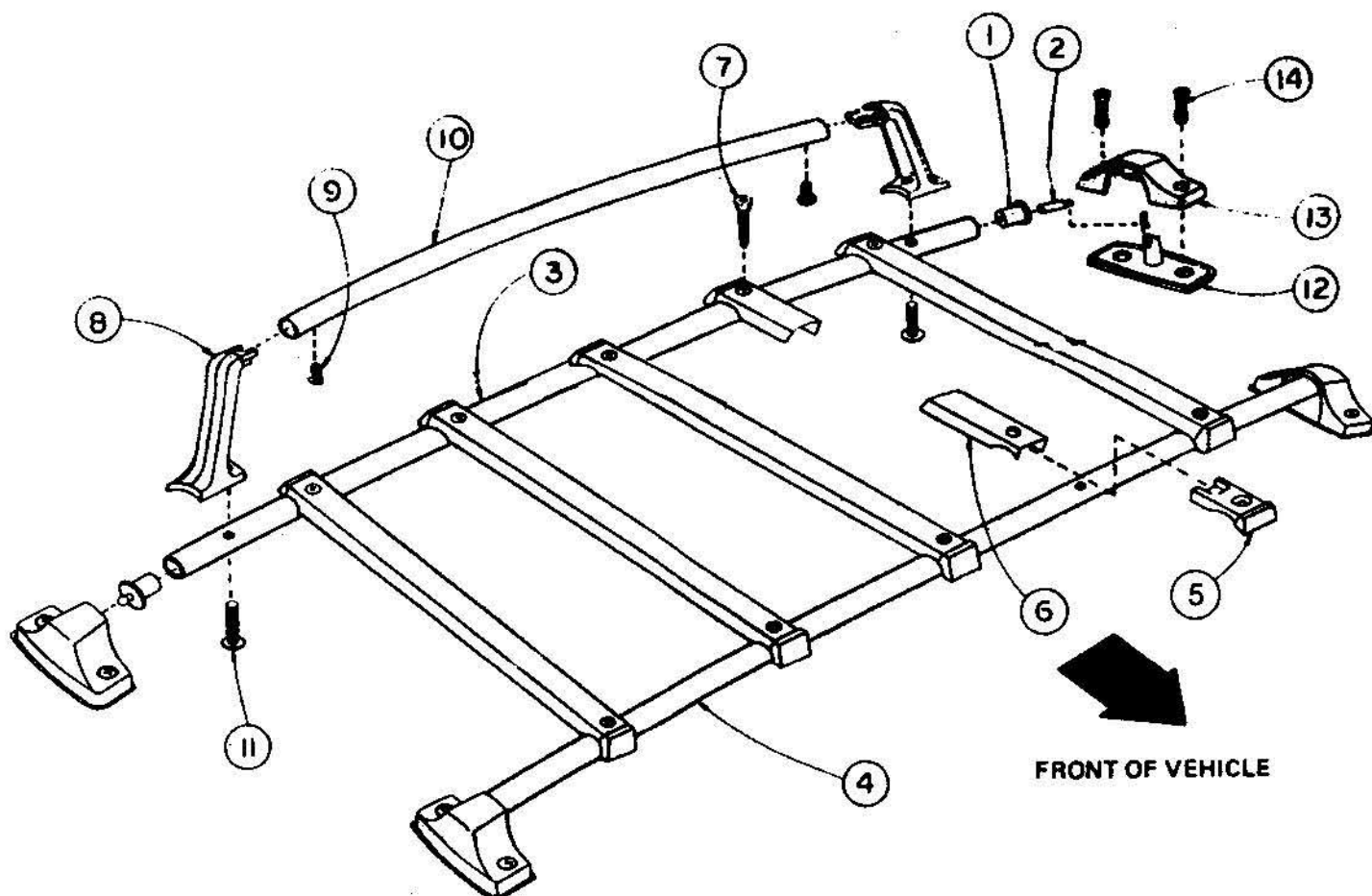

ASSEMBLY PROCEDURE

- (1) DRIVE PIVOT PLUGS (ITEM #1) INTO FRONT AND REAR RAILS (ITEMS #3 & #4), USING A SOFT HAMMER OR A BLOCK OF WOOD.
- (2) USING A SOFT HAMMER OR A BLOCK OF WOOD, DRIVE PIVOTS (ITEM #2) INTO PIVOT PLUGS (ITEMS #1). IMPORTANT: TO INSURE PROPER FIT, THE PIVOTS MUST BE DRIVEN THE FULL LENGTH OF THE PIVOT PLUG HOLE. IMPORTANT: SPHERICAL BALL MUST BE LOCATED OUTSIDE OF PIVOT PLUG.
- (3) INSERT THE PLASTIC END CAPS (ITEM #5) INTO THE LONGITUDINALS (ITEM #6).
- (4) MOUNT AND SECURE THIS LONGITUDINAL ASSEMBLY TO THE FRONT AND REAR RAILS (ITEMS #3 & #4) USING THE #10-16 X 1/2" LONG (12.7 MM) OVAL HEAD, SELF TAPPING, SCREWS (ITEM #7).

NOTE: DUE TO PRESSURE THAT IS EXERTED DURING THE TIGHTENING OF THE LONGITUDINAL ASSEMBLY TO THE RAILS, IT IS RECOMMENDED THAT A BLOCK OF WOOD BE PLACED UNDER THE CURVATURE OF THE RAIL AS A MEANS OF SUPPORT.

- (5) ASSEMBLE STANCHIONS (ITEM #8) TO THE TOP RAIL (ITEM #10) USING THE #10-24 X 3/8" LONG (9.5 MM) ROUND HEAD SCREWS (ITEM #9).
- (6) MOUNT THE STANCHION ASSEMBLY TO THE REAR RAIL (ITEM #3) USING THE 1/4-20 X 1.00" LONG (25.4 MM) PAN HEAD SCREWS (ITEM #11).
- (7) SNAP THE PIVOT BALL (ITEM #2) IN PLACE ON THE BASE GASKETS (ITEM #12) AS SHOWN.

INSTALLATION PROCEDURE

- (1) PLACE MASKING TAPE OVER APPROXIMATE AREA TO BE DRILLED TO PROTECT PAINT FINISH. CENTER CARRIER ON DECK. AFTER CHECKING LOCATION OF CARRIER, PLACE BRACKETS (ITEM #13) ON GASKETS (ITEM #12). USE BRACKET SCREW HOLES AS TEMPLATES BY MARKING HOLE CENTERS WITH PENCIL OR SCRIBER, BEING CAREFUL TO MAKE THE MARKS ON THE TAPE. WHEN THIS IS COMPLETED REMOVE BRACKETS FROM GASKETS THEN CAREFULLY LIFT CARRIER FROM VEHICLE.
- (2) CENTER PUNCH AND DRILL 9/64" (3.6 MM) DIA. HOLES AT MARKED LOCATIONS.
- (3) ATTACH LUGGAGE CARRIER ASSEMBLY TO DECK PANEL USING THE #10-16 X 3/4" LONG (19.05 MM) OVAL HEAD, WAXED SCREWS (ITEM #14). TIGHTEN SECURELY.

PARTS LIST

ITEM	NO. REQ'D.	PART NO.	PARTS DESCRIPTION
1.	4	05778	PIVOT PLUG
2.	4	05805	PIVOT
3.	1		REAR RAIL "(SPECIFY LENGTH)"
4.	1		FRONT RAIL "(SPECIFY LENGTH)"
5.	8 TO 12	04185	END CAP
6.	4 TO 6		LONGITUDINAL "(SPECIFY LENGTH)"
7.	8 TO 12	05897	SCREW #10-16x1/2" (12.7MM) OVAL HEAD
8.	2	05775	STANCHION
9.	2	00717	SCREW #10-24x3/8" (9.5MM) ROUND HEAD
10.	1		TOP RAIL "(SPECIFY LENGTH)"
11.	2	03788	SCREW 1/4-20x1.00" (25.4MM) PAN HEAD
12.	4	05843	GASKET
13.	4	04982	BRACKET
14.	8	02994	SCREW #10-16x3/4" (19.05MM) OVAL HEAD WAXED