



Owner Handbook



RSX 519

Introduction

Thank you for buying this RSX 519 coil-over suspension kit. RSX is the ultimate in performance with built-in race technology. Your kit is Epoxy Powder Coated and Dyno tested to the strictest TÜV standards. The dampers are Krypton Gas filled to give stunning high speed performance and better quality low speed ride. A well installed and set up RSX kit will transform the handling of your car. This handbook is designed to help you achieve this.

Safety First

- If working under or on a lifted vehicle, ensure that it is safely supported.
- If compressing a spring, ensure that the correct tools are used. Failure to do this can result in serious or fatal injury.
- SPAX dampers are gas pressurised. Never puncture, dismantle or incinerate.
- Performance suspension puts higher than normal loads on all other suspension components and car bodywork/chassis. All suspension components should be inspected for wear and for damage. They should be replaced if there is any doubt as to their condition.
- The literature contained with this suspension kit is meant as a guide only and is not comprehensive. SPAX Performance Ltd accepts no liability whatsoever for damage, loss or injury incurred as a result of using this literature.

Fitting Notes

- SPAX recommends that this kit be fitted by a suspension specialist. We can advise you on our Nationwide network of Authorised Fitting Centres.
- This kit is intended to lower your car using standard wheels and tyres. All non standard wheel and tyre combinations should be inspected for clearance, before fitment.
- Never grip or hit the damper piston rod. This will damage the highly polished surface, leading to premature damper failure
- Never use an impact wrench to tighten nuts and bolts.
- Never force the damper adjusters. Forcing them will cause damage.
- On ride height adjustable telescopic dampers, ensure the piston rod does not turn in the damper body when making ride height alterations or when pre-loading the spring. This may cause the damper internals to unscrew causing damper failure, damage or injury.
- To get the best results from your RSX kit, corner weights should be set. However, initially it is normally sufficient to ensure the spring seats are at the same height on each axle.
- After fitting, the tracking and (in some cases) the camber settings should be reset. These should be returned to factory settings where possible.

Kit Contents

2	G2034 Front Dampers	2	G2035 (L/R) Rear Dampers
2	A6400 Front Springs	2	CS815 Rear Springs
2	½" UNF Bolts	2	½" UNF Nyloc Nuts
8	½" Washers	8	½" Spacers
2	7/16" UNF Nyloc Nuts	2	7/16" Washers
2	3/8" UNF Bolts	2	3/8" UNF Nyloc Nuts
8	3/8" Washers	2	5/16" UNF Bolts
2	5/16" UNF Nyloc Nuts	6	5/16" Washers
8	¼" UNF Bolts	8	Spring Washers

Fitting Instructions

Front

1. Remove the existing damper units, upper mounting brackets, aluminium struts, rubber cone springs and vehicle bumpstops.
2. Loosely fit the new upper damper bracket on the original fixing using the $\frac{1}{4}$ " bolts supplied. We also recommend that the two extra holes on the bracket are used for increased strength.
3. Remove the top suspension ball joint nut. Loosely fit the top cradle with the $\frac{7}{16}$ " nut.
4. Loosely fit the two side plates using the $\frac{3}{8}$ " and $\frac{5}{16}$ " bolts making sure the double sided plate is towards the side of the car and the welded spacer is facing towards the back of the car.
5. With the $\frac{3}{8}$ " lower damper bolt loosely in position tighten the $\frac{5}{16}$ " bolt and the ball joint locknut to the correct torque as specified on the drawing below.
6. Remove the $\frac{3}{8}$ " bolt and loosely fit the damper (with spring fitted) with sufficient washers to space the unit in the bottom mount. With the damper held vertically fit the $\frac{1}{2}$ " upper bolt with the spacer tubes provided to ensure no sideways movement of the damper in the bracket. Re-check the damper is vertical, adjusting with the tubes/washers if necessary.
7. Tighten the $\frac{1}{4}$ " upper bracket bolts to the manufacturers torque setting before tightening the damper bolts to the setting given on the sheet with the suspension at ride height.

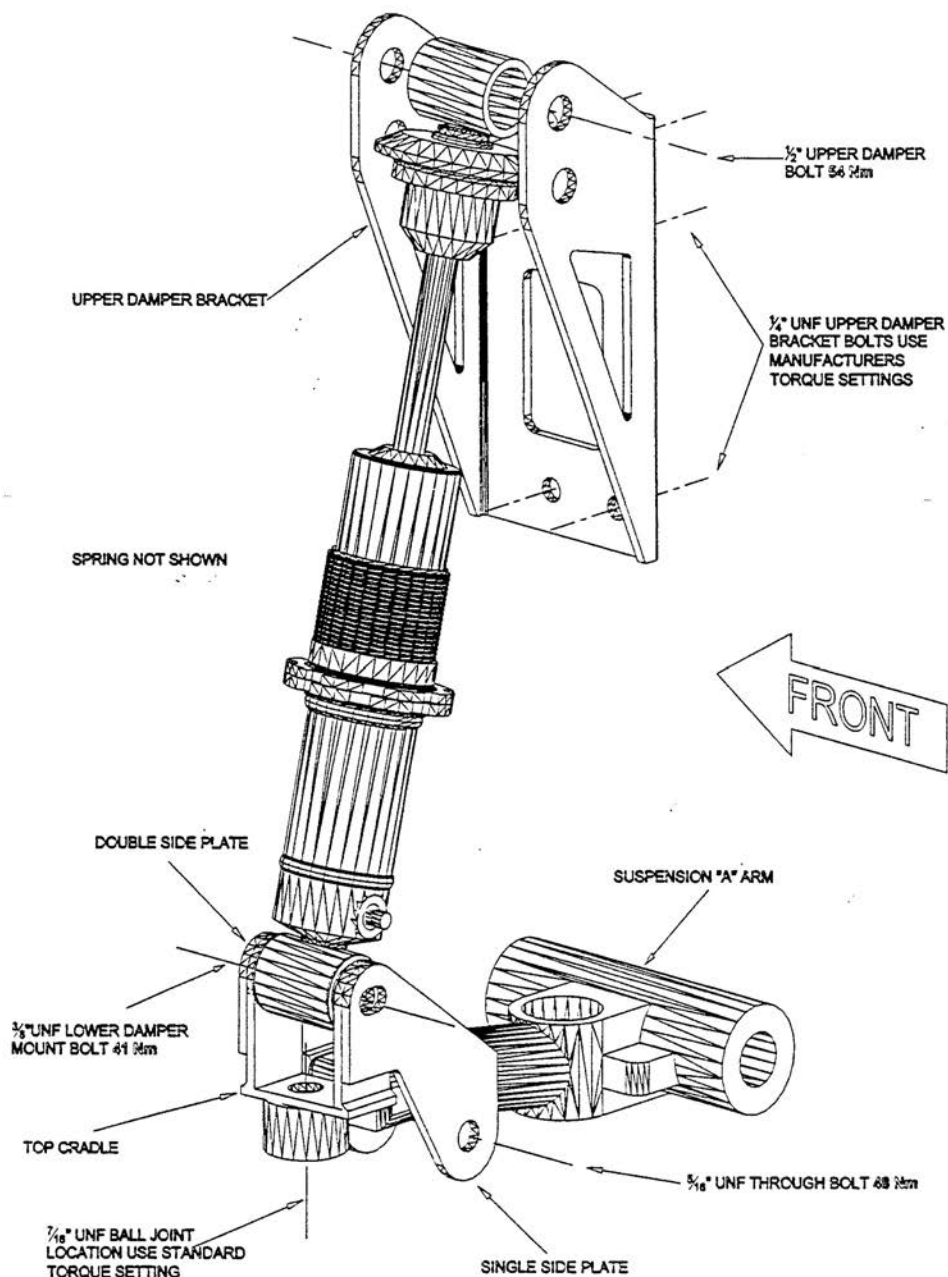

Rear

1. Remove the fuel tank to gain access to damper upper fixing. To do this the fuel tank should be empty.
2. Remove the standard damper units, aluminium suspension struts and rubber cones.
3. When viewing the inner wing from inside the wheel arch two thin steel reinforcing plates can be seen below the damper upper mounting point. These must be tapped back into the wheel arch using a suitable soft face hammer. Protection should be applied to any exposed metalwork.
4. When adequate clearance has been achieved fit the correct handed damper with the spring fitted to the radius arm (adjusters facing rearwards and the bottom loop offset towards the body of the car away from the radius arm). To fit the spring, remove the top stem by releasing the locknut. When refitting make sure the locknut is at the bottom of the thread.
5. Raise the radius arm and damper up until the pin passes through it's fixing point and tighten the bushing as for the standard damper. Tighten the bottom bush to the manufacturers torque setting with the radius arm at ride height.
6. Check there is clearance between the damper and the body and also the wheel/tyre.
7. Re-fit the fuel tank.

Setting Up

Your RSX kit is adjustable for corner weight setting and for damping force. All adjustments can be made without any dismantling of components, making it simpler, faster and easier to obtain your ultimate set-up.

Corner Weight Adjustment

- This kit is designed through the springs and dampers to run a specific ride height. The adjustable platforms are to allow corner weight adjustment.
- Always use the C-Spanners provided to adjust spring seat height.
- Always adjust spring seat height with no weight on the wheel.

Damping Force adjustment

- All Krypton Gas dampers have 28 stages of adjustment. This allows a wide range of adjustment to suit different driving styles and road conditions.
- Telescopic dampers (adjuster at the base) are adjustable in rebound and in bump.
- To obtain the ideal set up for you and your car, we recommend initially setting the dampers to:
Front: - 8 clicks up from fully soft (anti-clockwise);
Rear: - 6 clicks up from fully soft (anti-clockwise).
- Then adjust up in 4 click steps. Every time the driving sensation improves, carry on adjusting up by 4 clicks. Every time the driving sensation becomes worse, adjust down by one click.

Use

SPAX performance suspension is designed to improve the safety, performance and looks of your car. Performance suspension is normally noisier, stiffer and less comfortable than original equipment suspension.

This suspension kit has been designed for road use and for limited track day use.

Lowering and stiffening the suspension provides increased performance on smooth, grippy surfaces, but may result in some discomfort and loss of performance on bumpy roads.

Maintenance

Clean components using mild detergent and water. Never use abrasive products.

Long-term exposure to corrosive conditions (e.g. salt, acids) or driving in sandy or dusty conditions will reduce the life span of the components.

Regular lubrication of the threaded height adjuster and damper adjuster mechanism with a waxy corrosion inhibitor will prolong life of the components.

What makes SPAX special?

TüV Certification of the Company & Products - The toughest quality standard in Europe

POWDER COATING to give looks and protection that are second to none

DYNO TESTING of each and every damper so you get maximum performance and quality - guaranteed

GAS DAMPERS - Krypton pressurised for awesome high speed performance and superior low speed ride

Everything Adjustable on car, with no dismantling

