

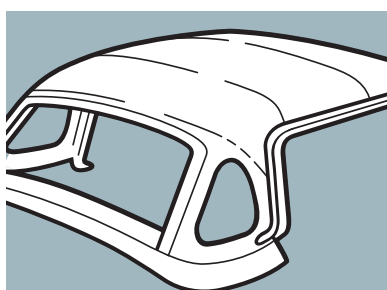

ISSUE 1

PARTS & ACCESSORIES FOR YOUR AUSTIN-HEALEY

including technical advice and detailed schematics

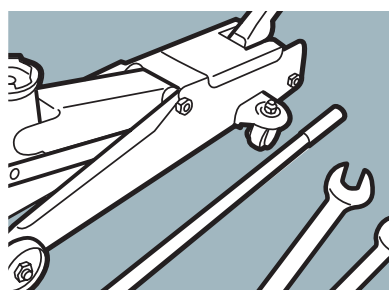
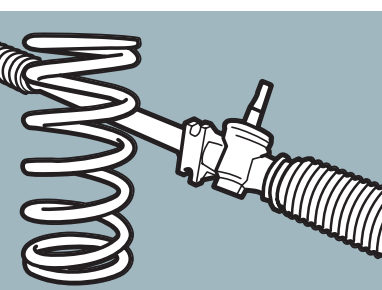
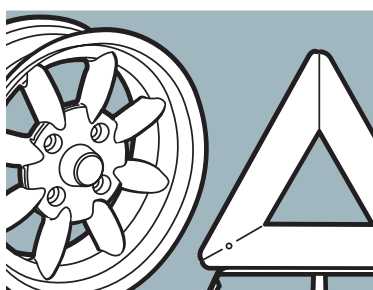
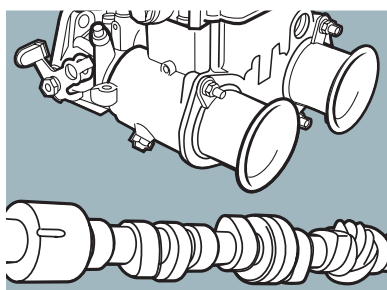
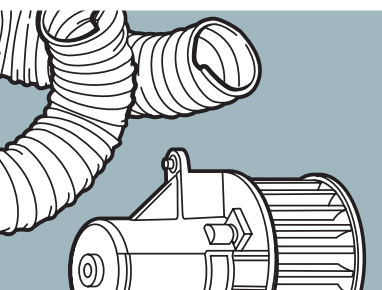
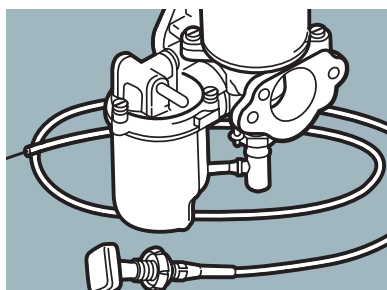
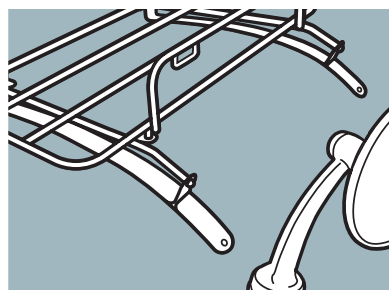
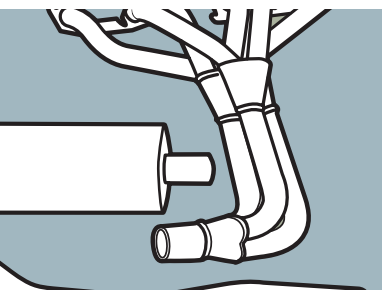
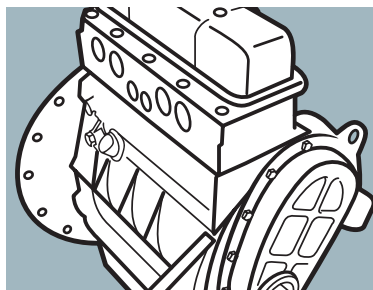
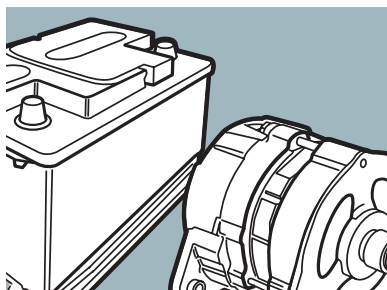
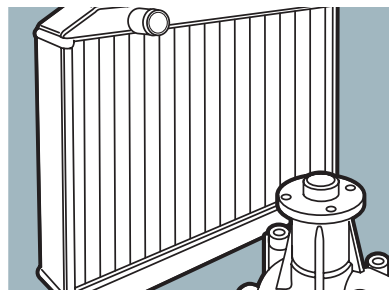
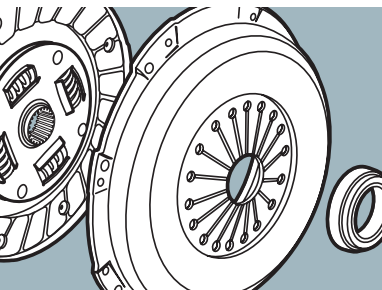
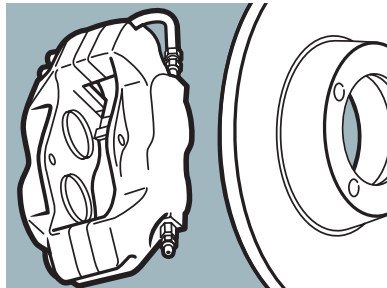
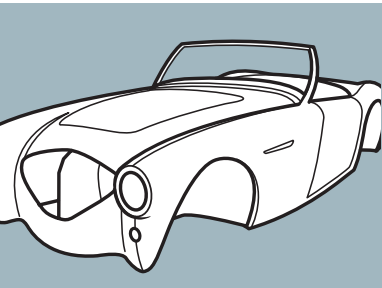

PARTS · ACCESSORIES · TOOLS

 Moss has been supplying Classic Car parts to enthusiasts since 1948. We specialise in MG, Triumph, Austin-Healey, classic Mini, Jaguar, Morris, and Mazda MX-5 parts and accessories, and offer a wide range of tools and consumables. Benefitting from decades of experience, we are now one of the world's oldest and largest suppliers to owners of classic cars.

Today, our mission is to keep the great marques alive and well by supplying parts and accessories of the highest standard. We offer friendly, professional, and knowledgeable service, and hold a vast inventory of parts in stock, backed by fast, reliable delivery throughout Europe.

EU based customers can now shop with Moss in the EU without worrying about customs charges or import taxes, and can benefit from fast and reliable delivery sent from Moss Paris across the EU.

- ✓ No customs charges
- ✓ No import taxes
- ✓ EU to EU shipping
- ✓ EU based sales and customer service team
- ✓ English speaking staff

 Moss fournit des pièces de voitures de collection aux passionnés depuis 1948. Nous sommes spécialisés dans les pièces et accessoires MG, Triumph, Austin-Healey, Mini classique, Jaguar, Morris et Mazda MX-5, et proposons une large gamme d'outils et de consommables. Forts de plusieurs décennies d'expérience, nous sommes de fait, l'un des plus anciens et des plus importants fournisseurs de propriétaires de voitures de collection au monde.

Aujourd'hui, notre mission est de maintenir les grandes marques en vie et en parfait état ce, en fournissant des pièces et des accessoires de la plus haute qualité. Nous offrons un service convivial, professionnel et compétent, et possédons une vaste gamme de pièces en stock, doublé d'une livraison rapide et fiable dans toute l'Europe.

Les clients basés au sein de l'UE peuvent désormais faire leurs achats chez Moss dans l'UE sans se soucier des frais de douane ou des taxes d'importation et peuvent bénéficier d'une livraison rapide et fiable expédiée depuis Moss Paris dans toute l'UE.

- ✓ Pas de frais de transitaire
- ✓ Pas de taxes d'importation
- ✓ Livraison de l'UE à l'UE
- ✓ Équipe de vente et de service à la clientèle basée dans l'UE
- ✓ Personnel parlant anglais

 Moss versorgt Oldtimer-Liebhaber seit 1948 mit Einzelteilen für Ihre Klassiker und ist mit seiner jahrzehntelangen Erfahrung einer der ältesten und größten Anbieter für Kunden in diesem Segment. Zu unserem Repertoire zählen Autoteile und Zubehör für die Marken MG, Triumph, Austin-Healey, den klassischen Mini, Jaguar, Morris und den Mazda MX-5. Darüber hinaus bieten wir eine breite Palette an Werkzeugen und Verschleißteilen an.

Mit unserer Arbeit möchten wir die großen Marken am Leben erhalten und liefern hierzu die hochwertigsten Teile und Zubehörartikel. Unser umfassender Lagerbestand kann schnell und zuverlässig an verschiedene Orte in ganz Europa versandt werden. Unser freundlicher, professioneller und fachkundiger Kundenservice berät Sie gerne dazu.

Kunden aus der EU können nun dank EU-Versand über Moss Paris ganz sorgenfrei bei Moss bestellen, ohne Zollgebühren oder Importsteuern zu zahlen.

- ✓ Keine Zollgebühren
- ✓ Keine Importsteuern
- ✓ Versand innerhalb der EU
- ✓ Vertriebs- und Kundendienstbüro in der EU
- ✓ Englischsprachige Mitarbeiter

 Moss fornisce parti per auto classiche agli appassionati dal 1948. Siamo specializzati in parti e accessori per MG, Triumph, Austin-Healey, Mini Classic, Jaguar, Morris e Mazda MX-5 e offriamo una vasta gamma di utensili e prodotti di consumo. Grazie all'esperienza decennale, ora siamo uno dei fornitori più vecchi e più grandi del mondo per i proprietari di auto classiche.

Oggi la nostra missione è mantenere vivi e in buone condizioni i grandi marchi, fornendo parti e accessori dello standard più elevato. Offriamo un servizio cordiale, professionale e competente e possediamo un vasto catalogo di parti in stock, supportato da un sistema di consegne veloce e affidabile in tutta Europa.

I clienti nell'UE ora possono acquistare da Moss nell'Unione Europea senza preoccuparsi di spese doganali o tasse di importazione e possono beneficiare della consegna veloce e affidabile da Moss Paris in tutta l'Unione.

- ✓ Niente spese doganali
- ✓ Niente tasse di importazione
- ✓ Spedizione in UE dall'UE
- ✓ Team di vendita e di assistenza clienti con sede in Europa
- ✓ Staff che parla la lingua inglese

 Moss lleva suministrando piezas a los amantes de los deportivos clásicos desde 1948. Estamos especializados en piezas y accesorios de MG, Triumph, Austin-Healey, Mini clásico, Jaguar, Morris y Mazda MX-5, y ofrecemos una amplia variedad de herramientas y consumibles. Gracias a las décadas de experiencia acumuladas, ahora somos uno de los proveedores más antiguos y grandes del mundo para propietarios de coches clásicos.

Hoy nuestra misión es mantener vivas y presentes las grandes marcas suministrando piezas y accesorios de la más alta calidad. Ofrecemos un servicio cercano, experimentado y profesional, y poseemos un extenso inventario de piezas en stock que se ve respaldado por un servicio de entrega a toda Europa rápido y fiable.

Ahora, los clientes de la Unión Europea (UE) pueden adquirir los productos de Moss directamente desde su territorio, sin preocuparse por las tarifas aduaneras ni los aranceles, y beneficiarse así de un servicio de entrega rápido y fiable a toda la UE desde Moss París.

- ✓ Sin tarifas aduaneras
- ✓ Sin aranceles
- ✓ Envío de UE a UE
- ✓ Equipo comercial y de atención al cliente basado en la UE
- ✓ Le atendemos en inglés

 A Moss tem vindo a fornecer peças de automóveis clássicos a entusiastas desde 1948. Especializamo-nos em peças e acessórios para MG, Triumph, Austin-Healey, Mini clássico, Jaguar, Morris e Mazda MX-5. Disponibilizamos também uma vasta gama de ferramentas e consumíveis. Com décadas de experiência, somos um dos maiores e mais antigos fornecedores de peças do mundo para proprietários de automóveis clássicos.

A nossa missão é manter as grandes marcas vivas e presentes, fornecendo peças e acessórios do mais alto nível. Oferecemos um serviço amigável, profissional e especializado, e mantemos um vasto inventário de peças em stock, apoiado por uma entrega rápida e fiável em toda a Europa.

Os clientes sedeados na UE podem agora efetuar compras na Moss Paris sem preocupações relativas a taxas aduaneiras ou impostos de importação, beneficiando também de entregas rápidas e fiáveis com envio a partir de França.

- ✓ Sem taxas aduaneiras
- ✓ Sem impostos de importação
- ✓ Envio da UE para a UE
- ✓ Equipa de vendas e apoio ao cliente sediada na UE
- ✓ Funcionários que falam inglês

A	Adjustable shock mount set A08	Door glass A37	King pin reaming tool A09	Throttle shaft bush set A22
Aerials A31	Aerosecreens A37	Door top rails A45	King pin set A09	Towing eye kit A36
Air filters A25	Air socks A25	Driving & fog lamps A34	Kneeling pad A50	Triplex glass A37
Alternator conversion kits A16	Aluminium panels A04	Driving lamp clamp A35	L	Trunnion bearing kit A09
Anti roll bars A08	Armrests A42	E	Lamp wiring harness A37	Tyre gauge A33
B	Badge bars & mountings A30	Embroidered patches A47	Laygears A20	U
Badges A29	Badges A29	Engine fasteners A27	Leaf springs A08	Umbrella A47
Bar stool A49	Batteries A16	Exhaust exit silencer A10	Leather key fobs A49	V
Batteries A16	Battery cut off switches A16	Exhaust fitting kits A10	Luggage straps A29	Valve & spring set A27
Battery tray A17	Beansies A47	Exhaust heat insulation A11-12	M	Valve caps A33
Bezel removal tool set A36	Body panels A04	Exhaust manifolds A10-11	Mikalor band clamps A11	Valve cover gaskets A26
Body panels A04	Bonnet & boot badges A30	Exhaust skid plate A11	Mirror riser A28	W
Bonnet & boot badges A30	Bonnet straps A30	Exhaust systems A10	Mirrors A28	Waterproof blankets A48
Books & Manuals A46	Books & Manuals A46	Exhaust U bolt clamps A11	O	Weber carburetors A23
Boot liner sets A44	Boot liner sets A44	F	Oil catch tanks A19	Wheel spacers A33
Boot racks A29	Bottle stoppers A49	Felt/rubber door seal A45	Oil cooler kits A17	Wheel spinners A32
Bottle stoppers A49	Brake caliper repair kit A06	Flag A49	Oil cooler radiators A17	Wheels A31
Brake calipers A05-06	Brake calipers A05-06	Flasher units A36	Oil pump strainer A19	Wheels & Tyres A32
Brake discs A05	Brake drums A06	Flying helmets & goggles A49	Oil seal conversion kits A19	White wall trims A32
Brake drums A06	Brake hoses A06-07	Footwell light kit A45	P	Wind wings A37
Brake hoses A06-07	Brake kit (disc brakes) A04	Footwell mats A44	Period style lamps A34	Windscreen glass A37
Brake light kit A35	Brake pads A05	Front coil springs A09	Pertronix ignition A14	Wine glass set A48
Brake pipes A07	Brake reservoir A07	Fuel caps A29	Pertronix ignition coils A15	Wing mirrors A28
Brake reservoir A07	Brake servo kit A06	Fuel hoses A22	Petrol can hip flask A49	Wire wheel hubs A33
Brake servo kit A06	Brake shoes A05	Fuel pressure regulators A21	Pinion gears A27	Wire wheel inner tubes A33
Brake shoes A05	Brass float A21	Fuel pumps A21	Pint cup A48	Wire wheel spokes A33
Bumpers A04	C	Fuel tanks A22	R	Wire wheel tools A33
Car covers A37	Carburettor balancer A24	G	Radiators A17	Workshop apron A47
Carburettor balancer A24	Carburettor conversion sets A23	Garage signs A49	Radios A50	Wosp high torque starter motor A15
Carburettor dashpot covers A25	Carburettor service kits A23	Gauges A40	Ram pipe kits A24	
Carburettor shafts A24	Cigar lighter A39	Gear knobs A40	Ram pipes A24	
Classic Gold fuel tank A22	Clutch hose A20	Gearbox rod bush kit A20	Rear brake kit (shoes) A06	
Clutch hose A20	Clutch linkages A20	Gearbox rod bushes A09	Rear hub nut socket A20	
Clutch linkages A20	Clutch pedal A20	Glove box lock A39	Rear spring bush set A09	
Clutch pedal A20	Clutch plates A20	Grille assemblies A31	Rev limiters A15	
Clutch plates A20	Competition lap belt A40	Groser jet A24	Reverse & fog lamps A35	
Competition lap belt A40	Complete car sets A45	H	Rocker covers A26	
Complete car sets A45	Complete panel kits A44	Head gasket sets A26	Rocker shafts & fittings A26	
Complete panel kits A44	Cool bags A48	Headlamp blanks A35	Rotor arms A15	
Cool bags A48	Carburettor float A24	Headlamp conversions A34	S	
Carburettor float A24	Crank balancer A26	Headlamp peaks A34	Scarf A48	
Crank balancer A26	CSI ignition A13-14	Headlamp protectors A35	Seat covers A44	
CSI ignition A13-14	Cup holder A47	Headlamp relay kit A36	Shock absorbers A08	
Cup holder A47	Cylinder heads A26	Headlamp rim A35	Side windscreen mirrors A29	
Cylinder heads A26	D	Headlamp stone guards A34	Smart screen wash/wiper system A38	
Dash LED bulbs A39	Decals A30	Headlamps A34	Snap straps A12	
Decals A30	Door 1/4 light mirrors A28	Heat shields A12	Spare wheel straps A32	
Door 1/4 light mirrors A28	J	Heated fleece blanket A49	Spark plugs & caps A15	
J	Jet bearing kits A25	Heel mats A44	Speakers A52	
Jet bearing kits A25	K	Hood frames A39	Spin-on oil filter A19	
K	K&N air filters A25	Hood stowage covers A39	Steering box & shaft A09	
K&N air filters A25		Hoods A38	Steering wheel covers A42	
		Horns A30	Steering wheels & bosses A41-42	
		HT leads A12	SU carburettor needle chart A25	
		I	SU carburetors A23	
		Idle screw kit A25	Sumps A19	
		Ignition lead numbering set A12	Sun catcher ornaments A49	
		Interior & dashboard mirrors A28	Suspension bush kits A08	
		T	Switches A35	
		Texas cooler fan A19		
		Thermal mug A48		

Sections

Performance A04

Exterior A28

Interior A39

Personal A46

BLACK & WHITE Restoration Section

Restoration
Parts 01

Where the price is replaced with NA this part is currently Not Available. Please visit our website (moss-europe.eu) or call our sales staff for the latest availability information or to enquire if we can offer an alternative part.

AHcat ©Copyright Moss Europe Ltd. August 2022. Printed in the EU. All rights reserved. No part of this publication may be reproduced, stored in a retrieval system, or transmitted in any form by any means, electronic, photocopying, recording or otherwise without prior written consent of Moss Europe Ltd. Please note: Product colours may vary slightly to samples featured in this catalogue, due to the limitations of colour printing.



ALUMINIUM PANELS

If you have to change any of your panels because they are corroded, why not to replace them with the aluminium version. You will never have to replace them again.

100-4

Front apron (BN1-BN2).....	858-130.....	€67,44
Bonnet assembly, plain (BN1-BN2).....	858-080.....	NA
Bonnet assembly, louvered (BN1-BN2).....	858-070.....	€978,00
Front wing, RH (BN1).....	858-105.....	€1.548,00
Front wing, LH (BN1).....	858-115.....	€1.548,00
Rear wing, RH (BN1).....	858-405.....	€1.074,00
Rear wing, LH (BN1).....	858-415.....	€1.074,00
Front wing, RH (BN2).....	858-125.....	€1.467,60
Front wing, LH (BN2).....	858-135.....	€1.467,60
Rear wing, RH (BN2).....	806-760.....	€1.068,00
Rear wing, LH (BN2).....	806-770.....	€1.068,00
Door skin, RH (BN1-BN2).....	858-165.....	€331,20
Door skin, LH (BN1-BN2).....	858-175.....	€331,20
Boot lid assembly (BN1-BN2).....	858-120.....	€1.304,40

100-6 & 3000

Front apron (BN4, BN6, BN7, BT7, BJ8).....	021-749.....	€68,16
Bonnet assembly, ribbed, (BN4, BN6 as fitted) ...	856-145.....	€1.353,60
Bonnet assembly, plain (BN6, BN7, BT7, BJ7, BJ8)	858-140.....	€1.231,20
Bonnet assembly, louvered (BN6, BN7, BT7, BJ7, BJ8)	021-751.....	€1.117,20
Front wing, RH (BN4, BN6, BN7, BT7, BJ7, BJ8)	858-055.....	€1.206,00
Front wing, LH (BN4, BN6, BN7, BT7, BJ7, BJ8)	858-065.....	€1.206,00
Rear wing, RH (BN4, BN6, BN7, BT7, BJ7, BJ8)	806-760.....	€1.068,00
Rear wing, LH (BN4, BN6, BN7, BT7, BJ7, BJ8)	806-770.....	€1.068,00
Door assembly bare, RH (BN4, BN6, BN7, BT7)	858-075.....	€1.018,80
Door assembly, bare, LH (BN4, BN6, BN7, BT7)	858-085.....	€1.018,80
Door skin, RH (BN4, BN6, BN7, BT7)	856-640.....	€620,40
Door skin, LH (BN4, BN6, BN7, BT7).....	856-650.....	€620,40
Boot lid assembly (BN4, BN6, BN7, BT7, BJ7, BJ8) .	858-005.....	€1.328,40



BUMPERS

Car bumpers aren't just an aesthetic feature at the front or rear part of the body. The main purpose of a bumper attached to these most conspicuous parts of your car is to keep you and your passengers safe, as well as to protect the car itself and minimise any damage in the event of an accident. Our bumpers are made of solid material, which provides wide areas in the front and rear of the car for effective protection. These bumpers are chromed for that authentic classic car look.

Front bumper (100-4)	854-260.....	€406,80
Rear bumper (100-4)	854-270.....	€416,40
Overrider, front or rear (100-4).....	27H9612.....	€101,52
Front bumper (100-6)	11B5303.....	€318,00
Rear bumper (100-6)	11B5312.....	€318,00
Overrider, front or rear (100-6 & 3000).....	11B5308.....	€63,60



BIG BRAKE KIT

Modern four piston calipers combined with our unique cross-drilled and slotted discs improve pedal feel and braking response.

Kit includes:

- A set of braided stainless steel hoses
- A set of pads for an all-around improvement that is reassuring in today's traffic
- Complete instructions

Drilled & slotted disc brake kit	586-725.....	€943,20
(BJ8 from (c)26705-on)		



BRAKE DISCS

Improved braking for your Big Healey. Get the stopping power you need with a Moss Exclusive. Cross Drilled holes lower brake temperatures and reduce rotational mass and out-gassing, while slots allow excess water, dirt, and dust to dissipate.

- Brake disc, single (BN7-BJ7, BJ8 to (c)26704)... BTC104 €41,64
- Brake disc, single (late BJ8)..... BTC371 €84,60
- Drilled & slotted discs, pair (late BJ8) 586-620..... €252,00



EBC BRAKE PADS

Designed for premium road driving offering better brake effect at loads and speed. EBC Greenstuff has a high initial brake effect and gives drivers confidence from first application of the brake pedal. There is no such thing as a no dust pad. The very nature of how a brake works requires that some dust be generated to avoid disc vibration (shimmying). The EBC pad creates less dust and dust is more easily washed off than most. All pads create more dust as they are bedding in especially if discs are worn. Nominal friction coefficient 0.55.

- Greenstuff brake pad set (BJ8 from (c)26705)... TT31501G.... €63,84



CLASSIC GOLD BRAKE SHOES

The Classic Gold range has been developed to directly replace hard to find original components, like brake shoes and other replacement parts.

- Brake shoe set, front (BN2-BN6) 8G8159..... €88,92
- Brake shoe set, rear (BN1-BJ8) LKKB1088.... €51,72



CLASSIC GOLD BRAKE PADS

Replace old and worn out brake pads with new ones to improve your braking. Our semi-metallic brake pad sets by Classic Gold offer:

- Shorter stopping distances
- Squeal free
- Less dusting than organic pads
- Asbestos free composition
- Anti-squeal compound bonded to brake pad backing
- No need to purchase expensive Anti-Squeal Shims

For the best brake pads Moss offers, step up to the Classic Gold Premium Ceramic Brake Pad which features:

- Withstands high braking temperatures
- Less fade
- Quicker recovery
- Ultra quiet braking
- Nearly dust free (Wire Wheel owners, this is the pad for you!)
- Anti-squeal compound bonded to brake pad backing (no need to purchase expensive Anti-Squeal Shims)

- Brake pads, semi-metallic (BN7-BJ8 to (c) C26704) . GBP116AF... €41,64
- Brake pads, semi-metallic (BJ8 from (c) C26705).. GBP114 €26,64
- Brake pads, ceramic (BN7-BJ8 to (c) C26704)... GBP116CM... €33,96
- Brake pads, ceramic (BJ8 from (c) C26705) GBP114CM... €45,84



BCC BRAKE CALIPER SET

Each BCC brake caliper kit contains a pair of BCC 4 pot calipers anodised in black, EBC Ultimax brake pads (including pins, clips and springs), bleed nipples, bridge and feed pipes. Each kit is a simple bolt-on installation requiring no permanent modification to the vehicle and is completely reversible.

- Using the proven BCC design the calipers are machined from Aerospace grade Aluminium for strength and durability.
- BCC calipers are hard anodised to prevent corrosion and then assembled.
- The pistons are made by BCC from 303 Stainless Steel to prevent corrosion and ensure a long life of faultless operation.
- The seals are supplied by British manufacturers of OEM automotive hydraulic seals.
- BCC calipers are fastened together with 10.9 grade high tensile steel bolts or high grade 316 HiMo Stainless Steel bolts certified to grade 10.9.
- They are supplied with Copper/Nickel Alloy hard lines with Brass fittings and EBC Ultimax brake pads.

- BCC brake caliper set, front (BN1- BN7, BT7) ... BCC105.... €1.040,40
- BCC brake caliper set, front (BJ7, BJ8) BCC104.... €1.040,40
- EBC brake pad set, Greenstuff (replacement)..... BCC202G €57,36
- EBC brake pad set, Ultimax (replacement)..... BCC202KV.... €47,04



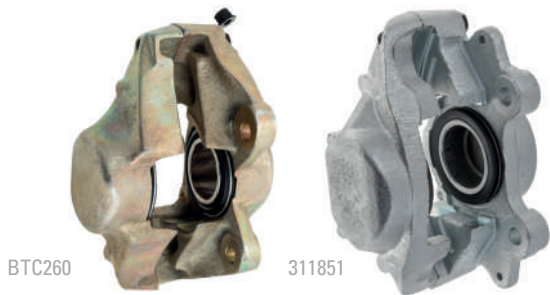

BRAKE CALIPERS

We have recently re-tooled to produce these high quality new brake calipers, supplied complete with pistons and seals and ready to fit. As these calipers are sold outright, there is no need to return old units and no additional surcharge. Please do not attempt to 'split' the calipers.

- Brake caliper, RH (BN7, BT7, BJ7, BJ8 up to (c)26704). BTC260 €308,40
- Brake caliper, LH (BN7, BT7, BJ7, BJ8 up to (c)26704). BTC261 €308,40
- Brake caliper, RH (BJ8 from (c)26705) 311851 €110,04
- Brake caliper, LH (BJ8 from (c)26705) 311852 €110,04

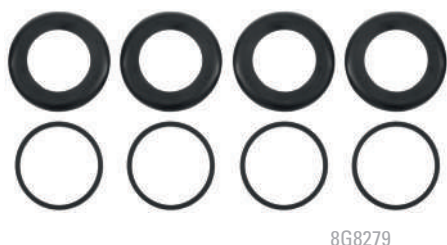

BRAKE CALIPER REPAIR KITS

The repair kits and pistons for 16P and 16PB calipers are different and they are not interchangeable. The later 16PB type kit (519731Z) differs from the early 16P kit (601960) in using a steel spring clip to retain the dust shield on the caliper body.

- Caliper seal set (BN7, BT7, BJ7, BJ8 to (c) 26704). 8G8279 €24,60
- Caliper seal set (BJ8 from (c) 26704) - aftermarket. 519731Z €19,80
- Caliper seal set (BJ8 from (c) 26705)..... 601960 €70,32

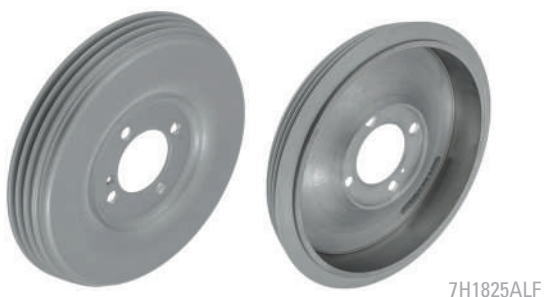

ALFIN STYLE BRAKE DRUMS

These Alfin style brake drums, reproductions of the rare factory alloy finned shell units, not only help to reduce brake fade under heavy braking, they also look great on your classic.

Sold individually.

- Alfin style brake drum, front 7H1825ALF .. €358,80 (BN1 to 228046)
- Alfin style brake drum, rear 7H1825ALF .. €358,80 (BN1 to 221535)
- Alfin style brake drum, rear 1B7526ALF .. €316,80 (BN1 from 221536, BN2, BN4, BN6, BN7, BT7, BJ7, BJ8)



REMOTE BRAKE SERVO KIT

For those who find the brake pedal rather hard after driving modern vehicles, these remote mounted servo kits will make braking easier by reducing pedal effort.

Suitable for all single-line brake circuits they are remote mounted and easily plumbed into the hydraulic and vacuum systems of the car.

We offer either a Lockheed or an aftermarket kit, both are supplied with mounting brackets and hardware.

- Remote brake servo kit, Lockheed TT3949..... €404,40
- Remote brake servo kit, aftermarket..... TT3949Z €139,56

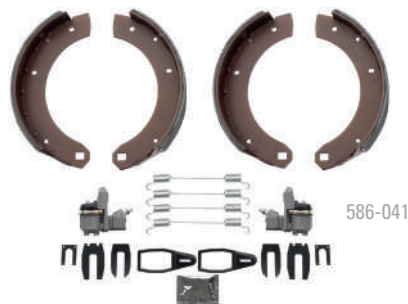

REAR BRAKE KITS

For your convenience we've grouped all the high quality parts you need for a complete rear brake job on a stock system.

The rear brake kit includes:

- 4 Brake Shoes
- 4 Brake Shoe Return springs
- 2 Wheel Cylinders
- 1 Fitting Kit

- Brake kit, rear (BN1-BN6) 586-041..... €149,04
- Brake kit, rear (BN7-BJ8) 586-042..... €143,88



COBALT STAINLESS STEEL BRAKE HOSE SETS

Stainless steel brake hoses provide a more direct and consistent brake feel. They won't expand like rubber hoses can. Order this complete set of long-lasting braided steel hoses for your next brake job. DOT approved.

- BN1, BN2, BN4 584-068..... €81,84
- BN6 584-098..... €55,56
- BN7 584-058..... €89,76
- BT7, BJ7, BJ8 584-078..... €73,80



GOODRIDGE BRAIDED HOSE SETS

Goodridge brake hose kits feature the finest quality hose, consisting of a PTFE inner with a stainless steel outer braid. This eliminates the spongy feel under arduous conditions, giving greater brake operation as well as providing superior resistance to abrasion and corrosion.

These kits, therefore, not only provide the reliability and safety demanded but offer brilliant good looks that improve the appearance of any installation. Every brake line made by Goodridge is 100% pressure tested and guaranteed to be leak free and give an improved braking performance. They are also 100% TUV, DOT, ADR and ISO approved and can be used worldwide.

- Brake hose set, black (BN1, BN2, BN4, BN6) GBL052190 . . . €93,12
- Brake hose set, clear (BN1, BN2, BN4, BN6) GBL052120 . . . €93,12
- Brake hose set, black (BN7) GBL052192 . . . €93,12
- Brake hose set, clear (BN7) GBL052122 . . . €93,12
- Brake hose set, black (BT7, BJ7, BJ8) GBL052191 . . . €93,12
- Brake hose set, clear (BT7, BJ7, BJ8) GBL052121 . . . €93,12

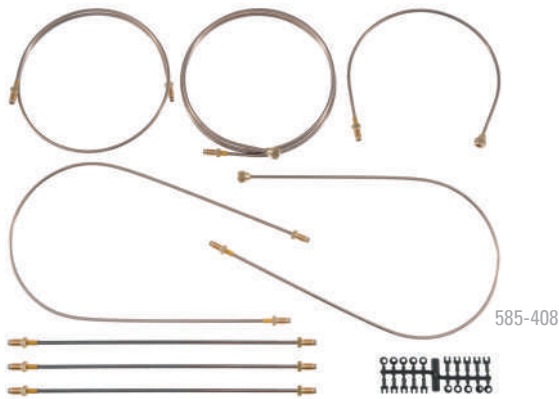

COPPER BRAKE PIPE SETS

These copper brake pipe sets are assembled for each specific model and are individually labelled to the instruction sheet, so there is no doubt as to where they fit on the car. Each pipe is cut to correct length and fitted with solid brass unions.

Won't rust as use only top quality copper and copper nickel tubing manufactured in Great Britain specifically for braking systems. All brake pipes are electrically and pressure tested to ensure that they meet the highest standards.

The pipes are supplied coiled but are strong and malleable, allowing them to be readily formed by hand or with pipe bending tool.

Copper/nickel brake pipe set

- RHD (BN1-BN2) 585-407 €191,04
- LHD (BN1-BN2) 585-408 €182,40
- RHD (BN4-BN6) 585-417 €158,16
- LHD (BN4-BN6) 585-418 €174,96
- RHD w/o servo (BN7, BT7, BJ7) 585-427 €175,68
- LHD w/o servo (BN7, BT7, BJ7) 585-428 €196,80
- LHD with servo (BN7, BT7, BJ7) 585-438 €189,36



GIRLING STYLE RESERVOIRS BY CLASSIC GOLD

Re-engineered and made to the highest modern standards, yet with great attention to detail that keeps it looking period-correct and authentic looking. These are the absolute best reproductions ever made of the Girling style reservoirs. Much time was put into researching the correct decals for these reservoirs, and these reproductions were designed by Roger Moment. Even the caps are correct - faceted and embossed where applicable.

Not only was great care taken to get the visual details right, but modern engineering makes this piece better than original. The black paint is resistant to all brake fluids. The cap is supplied with an improved 'no splash' reservoir seal which limits the exposure of the brake fluid to atmospheric moisture while preventing fluid from splashing against the underside of the cap. The vent holes in the inner and outer cap surface are offset, as they were originally. The vent design and the seal make it impossible for fluid to splash against the underside of the hood.

The original copper washers were prone to leak because the bottom of the can is very thin, and they cannot get an adequate 'crush'. This reproduction piece has special stainless steel washers that have integral DuPont Viton O-rings, with one on the inside and one on the outside to seal the outlet fittings. In testing, we found these seals to be effective and completely leak free with all types of brake fluid, even when we pressurized the reservoir (which of course will never happen in use).

- Brake reservoir, single outlet 3H920 €79,20 (BN1-BN2)
- Brake & clutch reservoir, dual outlet 114530 €74,76 (BN4 from (c) 48863, BN6-BT7 to early 1959)
- Brake & clutch reservoir with Girling decal 114530 €74,76 (BN7, BT7 from mid 1959, BJ7, BJ8)
- Decal, dual outlet tank 216-496 €4,20
- Reservoir label, Girling warning CRST148 €5,64





FRONT SHOCK ABSORBERS

Brand new lever arm front shock absorber for big Healey's. This new shock absorber has a later type of main body to the original as it has a half inch taller air chamber as part of the casting so check clearance when fitting. The good news is this design gives more consistent damping by helping to keep air and foam out of the main workings of the shock.

Shock absorber, front (100-4, 100-6 & 3000) .. GSA111 €247,20



REAR SHOCK ABSORBERS

New rear lever arm shock absorbers for big Healey's. These are brand new shocks, not reconditioned units.

RH (100-4, 100-6, 3000 to BJ8 (c)26704) 1B7445 €177,48
 LH (100-4, 100-6, 3000 to BJ8 (c)26704) 1B7448 €177,48
 RH (3000 BJ8 from (c)26705) GSA153 €182,40
 LH (3000 BJ8 from (c)26705)..... GSA154 €182,40



UPRATED SHOCK VALVES

About 25% stiffer than standard valves. For race purposes. Sold individually.

Shock valve, front (BN1-BJ8) 655-060 €38,04
 Shock valve, rear (BN1-BJ8) 655-070 €38,04



ADJUSTABLE SHOCK MOUNT SET

Adjustable camber is useful for a road car, but essential for racing or other high performance driving to take advantage of modern tyre design. This kit replaces the original shock mount plates that are welded to the top of the Healey frame towers, using a tapped plate machined from high tensile strength steel which can be adjusted in and out with two horizontal bolts to give exactly the correct camber adjustment you desire.

Adjustable shock mount set (BN1-BJ8) 856-115 €456,00



ANTI-ROLL BARS

The standard front anti-roll bar will need uprating when the engine and suspension are modified. The front anti-roll bar is supplied separately, we suggest you also replace the fittings and bushes.

Anti-roll bar 5/8", uprated (BN1-BJ8) 031-281 €164,88
 Anti-roll bar 3/4", uprated (BN4-BJ8) 031-495 €175,80
 Bush, anti-roll bar mounting 5/8" 1B4526 €1,92
 Bush, anti-roll bar mounting 3/4" AHH7927 €2,16

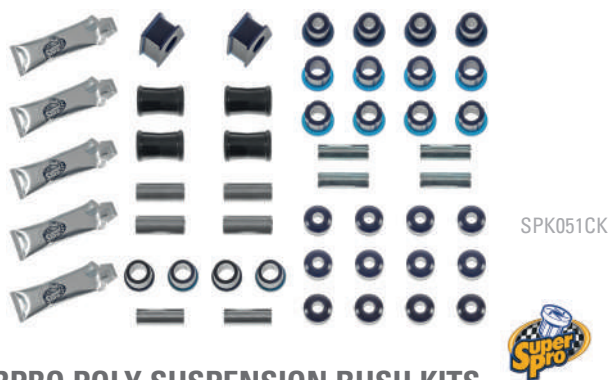

SUPERPRO POLY SUSPENSION BUSH KITS

SuperPro bushes are tried, tested and proven in motorsport, which means they deliver outstanding performance. Their innovative design and superior materials offer dramatic improvements in handling and give a more precise feel through the corners. Unlike some polyurethane bushes, with SuperPro products there is no increase in vibration or ride harshness, an attribute that makes them an ideal choice for cars that are used for both normal road driving and track days.

Complete car bush kit (BN1-BN7, BT7, BJ7).. SPK051CK €338,40
 Complete car bush kit (BJ8) SPK052CK €496,80
 Sway link set (BN1-BJ8)..... 3H3079SPK €22,56
 Control arm set (BN1-BJ8) ACB9274SPK.... €94,08



REAR LEAF SPRINGS

Apart from fitting front anti roll bar, you must also ensure that the rear spring doesn't spoil all your hard work at the front. See our selection of rear leaf springs.

BN1, BN2 1B8929 €129,36
 BN4, BN6, BN7, BT7, BJ7, BJ8 to (c)26704... 11B5266X €152,16
 BJ8 from (c)26705 AHB9980X.... €128,52



KING PIN SET

King pin pair complete with bushes, lower fulcrum pins, cotter pins, seals, shims, grease nipples, washers and nuts required to fit. King pin bushes need reaming once fitted.

King pin set (BN1-BJ8) QHQP295TCF €147,96



386-375

KING PIN REAMING TOOL

This kingpin reaming tool ensures that your swivel pin bushings are perfectly aligned. This purpose-built tool is a great addition to any Austin-Healey owner's collection.

King pin reaming tool..... 386-375 €554,40

Pin, cotter, UNF 53K1770..... €4,08

Pin, fulcrum, lower link, outer 1A4788..... €14,28



031-195

TRUNNION BEARING KIT

Replace your factory thrust washer with our useful Top Trunnion Bearing Kit. Greatly reducing friction, it helps you steer and manoeuvre your Healey with noticeable ease. This high quality kit replaces the bronze thrust washers in the top trunnions and should not be confused with cheaper alternatives available in the market.

Trunnion bearing kit (BN1-BJ8) 031-195 €58,92

Trunnion shim, 0.004" 031-196 €1,08



661-910

FRONT COIL SPRINGS

These springs differ slightly from original, but are the closest available replacement. Must be fitted in pairs.

Coil spring, front..... 661-910 €50,76
(BN1, BN2, BN4 from C.E.35077 LHD & 35827 RHD, BN6, BN7 to (c)10328, BT7 to (c)10302)

Coil spring, front..... 1H4092 €64,08
(BN7 from (c)10329, BT7 from (c)10303, BJ7, BJ8)



POLY SWAY BAR, PANHARD ROD & GEARBOX ROD BUSH

Tighten up your Healey. These exclusive polyurethane bushings directly replace the sway bar, Panhard rod or gearbox restraint rod bushes. The black coloured bush is suitable for restoration use and has a hardness of approximately 95 shore A.

Bush, polyurethane, each (BN1-BJ8)..... 021-777 €6,00



POLYURETHANE REAR SPRING BUSH SET

Enjoy increased performance and a prolonged life with the brand new polyurethane bushing set. A consistently top quality product, each bushing in this set has been made with a shore hardness 80 and are dark blue. Featuring a unique lip seal, the cross-hatched surface inside the bore of these bushes retains the special polyurethane-safe grease which is included with each set. Manufactured from USA produced urethane. Application specific.

Rear spring bush set (BN1-BJ8) 680-961 €42,24



HIGH RATIO STEERING BOX & SHAFT ASSEMBLY

Give your Healey the sharp, sports car response it was always meant to have with a quick-ratio steering box. Manufactured in England, our High-ratio Steering Box and Shaft Assembly is lock-to-lock in 2.5 turns compared to a standard box at 3.25 turns.

BN4 (c)68960 on, BN6, BN7, BT7, BJ7, BJ8... 667-831 €1.927,20

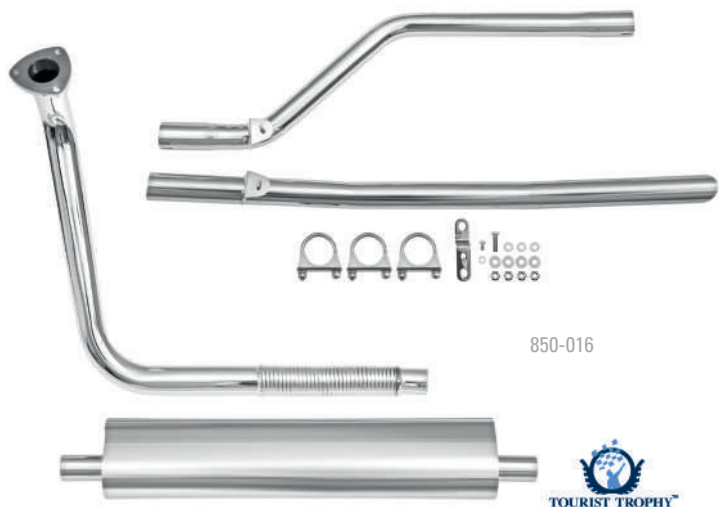

850-016



TOURIST TROPHY STAINLESS STEEL EXHAUST SYSTEMS

Treat your Austin-Healey to one of the finest sports exhausts available... These superb Tourist Trophy polished stainless steel sports exhaust systems are manufactured using the highest quality materials and workmanship. The systems are manufactured from highly polished stainless steel and the silencer is packed with a combination of stainless steel wire wool and fibreglass, this give a throaty exhaust note under acceleration that isn't intrusive when cruising.

- 1.2mm thick 304 grade stainless steel
- 409 stainless steel used for inner core and perforated tubing
- Entire system is polished to a mirror shine
- CNC cut flange
- Tail pipe angled away from overrider
- 5 year limited warranty*

Warranty information

This systems are warranted to the original purchaser of record and for the original vehicle on which the product was installed, against defects in materials and workmanship for 5 years. Moss' sole obligation under this warranty shall be limited to repair or replacement at Moss' option, provided that the silencer discloses a manufacturing defect. Warranty is void if any defects are caused by a physical impact of any kind.

BN1-BN2.....	850-016	€433,20
BN4, BN6, BN7, BT7, BJ7	610-145	€632,40
BJ8.....	850-001	€886,80

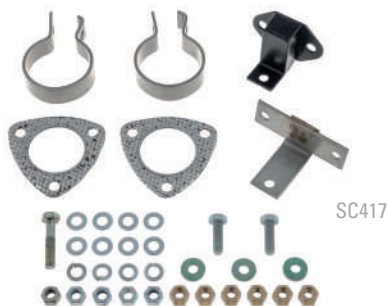

SC417

EXHAUST FITTING KITS

Fitting kit, exhaust system (BN1-BN2).....	SC420.....	€38,28
Fitting kit, exhaust system (BN4-BJ7).....	SC421.....	€50,64
Fitting kit, front, stainless steel (BJ8)	SC417.....	€55,08
Fitting kit, centre, stainless steel (BJ8)	SC418.....	€71,04
Fitting kit, rear, stainless steel (BJ8)	SC419.....	€69,48

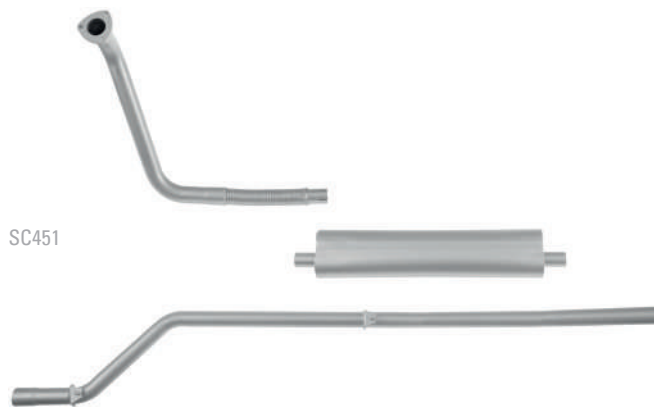

SC451

PERFORMANCE EXHAUST SYSTEMS

Constructed entirely of top quality stainless steel or mild steel. Includes all pipes from the manifold flange back. Clamps and hangers are not included. Some 100 clutch pedals will hit the exhaust downpipe. This is true for both the original pipes and the Moss exhaust system.

Exhaust system, mild steel

BN1, BN2	SC451.....	€405,60
BN4, BN6, BN7, BT7, BJ7	SC452.....	€567,60
BJ8.....	SC453.....	€694,80

Exhaust system, stainless steel

BN1, BN2	SC451SS.....	€364,80
BN4, BN6, BN7, BT7, BJ7	SC452SS.....	€612,00
BJ8.....	SC453SS.....	€978,00



021-961

PERFORMANCE EXHAUST MANIFOLD & SIDE EXIT SILENCER

Compared to an original manifold, the Free Flow Inlet Manifold provides distinctly better air flow, therefore improving the air-fuel ratio to the engine. It produces a flatter torque curve which results in a smoother drive and an increase in power. For the best results use with 2" HD8 carbs and 6 branch exhaust manifold, but it can be used with smaller 1 3/4" carbs and the OE cast iron exhaust manifold.

Manifold (Late BN4-BJ8)	021-960	€1.027,20
-------------------------------	---------------	-----------

Boost your car's performance and add a racer look with the 304 stainless-steel performance exhaust manifold and side exit muffler. Manufactured using sophisticated pipe bending technology, these tubular manifolds result in optimum exhaust gas flow. Designed for the BJ8, it can be installed on all the 3000 models with slight modifications. The Exhaust Side Exit Muffler with its 2 inch diameter bore adds a sporty look to your car. Reasonably priced. Great buy for any vintage racing enthusiast.

Note: Both parts should be used together otherwise custom exhaust work would be required. Designed for the BJ8, but can be installed on all the 3000 models with slight modifications.

Manifold (BJ8 1963-68).....	021-961	€1.261,20
Side exit exhaust (BJ8 1963-68)	021-962	€604,80



021-964

PERFORMANCE EXHAUST MANIFOLD

Get maximum performance and optimum gas flow with our brand new exhaust manifolds. Based on the 6 branch manifold designs, the exhaust manifolds have 1 3/4" collectors into 2" outlet pipes. Manufactured using mandrel bending process, the bore of the pipes is not reduced, ensuring an unrestricted gas flow.

Available in two choices, you can select a manifold that can only be used with SU carbs or only with triple Weber carbs. The thicker gauge, mild steel pipe reduces noise levels and is finished in heat-proof paint. Reasonably priced. Useful buy!

Note: This system will require the front left hand outrigger to be modified to fit the BJ8.

Exhaust Manifold

- BN6-BJ8 with SU carbs 021-964 €969,60
- BN6-BJ8 with triple Weber carbs 021-965 €962,40

Side exit exhaust

- BN4-BJ8 with OE manifold 021-956 €577,20
- BN4-BJ8 with performance manifold 021-957 €620,40 (021-964 or 021-965)



GAC185



GAC9908X

THERMO-TEC HEAT INSULATION MATERIAL

This general purpose material is designed to prevent heat damage in a variety of applications. It can be used to cover bulkheads and floors to keep general heat transfer to the cockpit to a minimum. It can also be used to wrap and cover components in the engine bay to prevent heat damage. This race proven, asbestos free, product from Thermo-Tec is manufactured using an aluminised coating on a woven backing. The material can be easily cut to the required shape and retained with high temperature adhesive, rivets & washers or snap straps depending on where you want to use it.

- Heat insulation material, 1m x 1m GAC185 €126,72
- Heat shield, catalytic converter / silencer GAC184 €140,76
- High temperature adhesive GAC9908X €18,12



EXHAUST SKID PLATE

The BJ8 stock type exhaust hangs very low. The lower front edge of the two silencers under the driver's seat (LHD) can catch on speed bumps, high spots in the road, driveway slopes and so on. Hit something hard enough and you can actually damage the entire exhaust system. This heavy duty, 14-gauge stainless steel skid plate will take the abuse that would otherwise damage the exhaust and will not rust.

- Exhaust skid plate (BJ8) 850-003 €82,68



TT9932S



TT9930S



TT9937S

REPLACEMENT MIKALOR BAND CLAMPS

Mikalor stainless steel band clamps are the best clamps available. Designed and manufactured to the highest standards using stainless steel bands and zinc plated screws. The design of the screw mechanism means that it is impossible to lose the screw and trunnion and the bevelled edges of the band gives protection against abrasion. The design of these clamps and material specification means they are ideal for motorsport applications. The screw and trunnion is designed to take higher torque than standard 'worm drive' hose clamps, this gives increased clamping grip for high pressure use. These clamps are suitable for use on hoses and exhaust systems, the thin band design allows installation where pipes run close together, such as manifold Y pieces and collectors.

- Exhaust clamp, 1 11/16" - 1 7/8" (43-47mm) .. TT9932S €6,24
- Exhaust clamp, 1 7/16" - 1 9/16" (37-40mm) .. TT9930S €4,44
- Exhaust clamp, 1 7/8" - 2" (47-51mm) TT9933S €4,44
- Exhaust clamp, 1 9/16" - 1 11/16" (40-43mm) . TT9931S €4,80
- Exhaust clamp, 2 1/2" - 2 11/16" (63-68mm) .. TT9938S €5,16
- Exhaust clamp, 2 5/16" - 2 1/2" (59-63mm) ... TT9937S €5,64
- Exhaust clamp, 2 5/32" - 2 5/16" (55-59mm) .. TT9936S €5,04
- Exhaust clamp, 2" - 2 5/32" (51-55mm) TT9934S €4,56



GEX9004



GEX9011



GEX9009

REPLACEMENT U BOLT STEEL EXHAUST CLAMPS

- Exhaust clamp, 1 1/2" (38mm) GEX9004 €2,04
- Exhaust clamp, 1 1/4" (32mm) GEX9002 €1,56
- Exhaust clamp, 1 3/4" (44mm) GEX9007 €1,80
- Exhaust clamp, 1 3/8" (35mm) GEX9003 €1,32
- Exhaust clamp, 1 5/8" (41mm) GEX9005 €1,92
- Exhaust clamp, 1 7/8" (47mm) GEX9008 €1,44
- Exhaust clamp, 2 1/2" (63mm) GEX9013 €2,04
- Exhaust clamp, 2 1/4" (57mm) GEX9011 €1,80
- Exhaust clamp, 2 1/8" (54mm) GEX9010 €1,44
- Exhaust clamp, 2 3/8" (60mm) GEX9012 €1,80
- Exhaust clamp, 2" (50mm) GEX9009 €1,80



EXHAUST HEAT INSULATION

Wrapping a tubular manifold will keep engine bay heat to a minimum, reducing engine bay temperatures by up to 70%. This will benefit power in two ways; firstly it will reduce the temperature of the air going into the engine; secondly, it improves the effectiveness of the manifold by increasing gas speed due to lower gas density, increasing the scavenging effect. Manifold wrap is supplied in rolls in a variety of sizes. Use Snap Straps to hold the wrap or blanket in position.

Roll size (w x l)

1" x 15' roll, natural.....	GAC150.....	€21,36
2" x 15' roll, natural.....	GAC152.....	€36,84
1" x 50' roll, natural.....	GAC154.....	€63,60
2" x 50' roll, natural.....	GAC156.....	€105,72
1" x 15' roll, black	GAC151.....	€24,12
2" x 15' roll, black	GAC153.....	€39,60
1" x 50' roll, black	GAC155.....	€70,56
2" x 50' roll, black	GAC157.....	€115,56

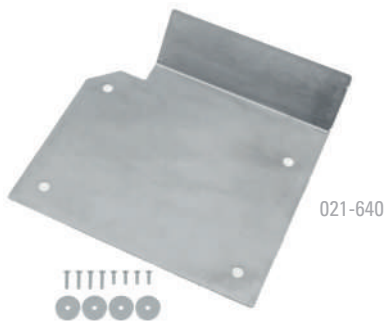

HEAT SHIELDS

Our R&D department has developed two supplemental heat shields, one for the footbox, and one to go under the floorboard over the exhausts. The exhaust heatshield extends down on each side, shielding the frame rails from the exhausts. Both of our heat-shields start with substantial stainless steel plates, and we add aluminised ceramic fibre insulation. You will secure these heat-shields using the same attachment points as the OE panels. We offer the footbox panel (021-640) for all LHD 6-cylinder Healey's, and the exhaust panel (021-641) for the LHD 3000 MKII & MKIII only - Exhaust heat-shields are not recommended for the MKI 3000 because with no factory heat shield ever fitted, there are no mounting points.

Footbox/firewall panel, LHD (100-6, 3000) ...	021-640	€161,40
Silencer panel, LHD (3000 MkII & MkIII only)	021-641	€206,76



SNAP STRAPS

Snap Strap kit 8 x 9" & 4 x 18" lengths	GAC172.....	€59,28
Snap Strap kit 6 x 9" & 4 x 18" lengths	GAC173.....	€49,44
Snap Strap kit 12 x 9" lengths	GAC174.....	€53,04
Snap Strap kit 6 x 18" lengths	GAC175.....	€35,40
Snap Strap kit 4 x 14" lengths	GAC176.....	€19,20

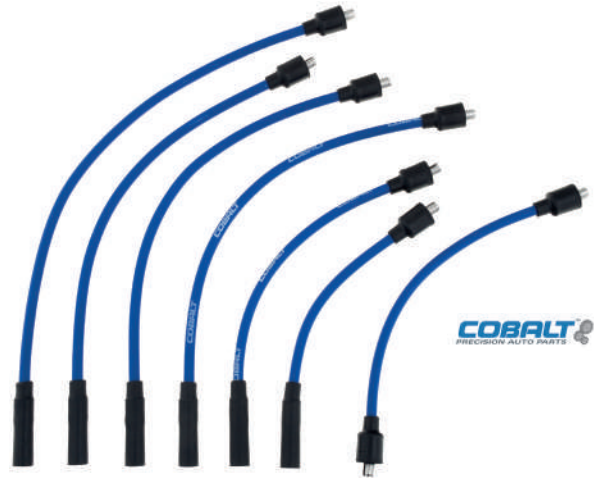

COBALT SILICONE HT LEAD SET

Cobalt Ignition Wire Sets are made precisely for your vehicle, and carry a Lifetime Warranty against defective materials or workmanship! Cobalt Wires feature:

- Compact Silicone Plug Boots provide extra clearance
- EPDM Layer provides more electrical insulation than silicone-over-silicone
- Conductive Polymer Coating protects the conductor and provides terminal contact
- Stainless Steel Conductor for maximum conductivity
- Aramid Fibers provide superior tensile strength
- Spiral Magnetic Core suppresses RFI/EMI interference
- Fiberglass Braid provides superior tensile strength
- 8mm Silicone Jacket resists high temperatures, fuels and oils
- Locking Terminals stay connected under high vibration

Cobalt HT lead set, blue (BJ7-BJ8)	171-665	€80,88
--	---------------	--------



BUMBLEBEE' COMPETITION HT LEAD

If you want a performance HT lead with the correct period look then this 'bumblebee' lead is a must. As per the original 'Lucas' type it features a high conductivity copper core with a yellow insulator featuring a black stripe. Alternatively, use the standard black lead for an 'OE' look.

Bumblebee HT lead (per metre).....	TT2982M	€10,68
HT lead, black (per metre).....	AAA5981M.....	€5,40



HT LEAD NUMBERING SET

Keep track of which HT lead is which with a set of four numbered sleeves.

HT lead numbering set 4 cylinder	CRST255.....	€6,84
HT lead numbering set 6 cylinder	171-640	€18,72



CSI IGNITION DISTRIBUTORS

CSI-Ignition distributors offer a fully electronic ignition system built into the correct type of Lucas distributor housing to suit your car, keeping the original appearance in the engine bay. You can only tell the difference when you remove the distributor cap!

Gone are the points and condenser and mechanical advance mechanism, all replaced with a high quality electronic ignition system manufactured using military specification components for durability and reliability. These distributors are maintenance free (no points to adjust), and offer the benefits of, easier starting & smoother running, more torque & power, reduced fuel consumption & emissions. They also eliminate the weaknesses of mechanical timing advance and problems such as points bounce ensuring correct ignition timing throughout the rev range.

Each CSI-Ignition distributor features 16 easily switchable, optimised ignition curves to allow timing adjustment to suit your car's engine and fuel specifications. Alternative advance curves can be selected to suit your engine's state of tune making them ideal for modified engines. Curves are easily selected using a screwdriver in a rotary switch, with a bright flashing LED indicator to show the selected curve all concealed underneath the distributor cap. As the CSI-Ignition distributor uses the correct type of distributor body for the application it is a direct swap. Full instructions and ignition curve selection guidance is included.

We offer a wide range of CSI-Ignition distributors for a variety of applications.

Optimised:

Suitable for standard and lightly tuned engines with vacuum advance (push-on type only). Suitable for cars running on SU carburettors.

Tuned:

Suitable for engines without vacuum advance. Suitable for the more tuned engines using Weber carburettors. With this implementation, you can often achieve better torque and power results, because by the absence of the vacuum advance unit, it is less likely to suffer from detonation under partial load.

Immobilizer:

Some CSI's offer an immobilizer in combination with the electronic ignition. This immobilizer is easy to install and will prevent your car from being started. You can invisibly install the immobilizer receiver under the dashboard. It works with a sensor hidden in a luxury leather key hanger with a unique code (no battery needed). As soon as the key hanger is near the receiver, your CSI will be activated and you can start your car. Without the key hanger the ignition won't work and your car won't start.

Tuned with immobiliser

23D4 negative earth (BN1-BN2)	CSD0523681 ..	€595,20
23D4 positive earth (BN1-BN2)	CSD0523671 ..	€595,20
23D6 negative earth (BN4-BN6)	CSD0523682 ..	€652,80
23D6 positive earth (BN4-BN6)	CSD0523672 ..	€652,80
25D6 negative earth (BN7-BT7-BJ7)	CSD0523686 ..	€652,80
25D6 positive earth (BN7-BT7-BJ7)	CSD0523676 ..	€652,80
25D6 negative earth (BJ8)	CSD0523687 ..	€618,00
25D6 positive earth (BJ8)	CSD0523677 ..	€618,00

Tuned without immobiliser

23D4 negative earth (BN1-BN2)	CSD0523581 ..	€388,80
23D4 positive earth (BN1-BN2)	CSD0523571 ..	€388,80
23D6 negative earth (BN4-BN6)	CSD0523582 ..	€446,40
23D6 positive earth (BN4-BN6)	CSD0523572 ..	€446,40
23D6 negative earth (BN7-BT7-BJ7)	CSD0523584 ..	€446,40
23D6 positive earth (BN7-BT7-BJ7)	CSD0523574 ..	€446,40
23D6 negative earth (BJ8)	CSD0523585 ..	€412,80
23D6 positive earth (BJ8)	CSD0523575 ..	€412,80

Optimised with immobiliser

25D4 negative earth (BN1-BN2)	CSD0514681 ..	€618,00
25D4 positive earth (BN1-BN2)	CSD0514671 ..	€618,00
25D6 negative earth (BN4-BN6)	CSD0514682 ..	€675,60
25D6 positive earth (BN4-BN6)	CSD0514672 ..	€675,60
25D6 negative earth (BN7-BT7-BJ7)	CSD0514686 ..	€675,60
25D6 positive earth (BN7-BT7-BJ7)	CSD0514676 ..	€675,60
25D6 negative earth (BJ8)	CSD0514687 ..	€640,80
25D6 positive earth (BJ8)	CSD0514677 ..	€640,80

Optimised without immobiliser

25D4 negative earth (BN1-BN2)	CSD0514581 ..	€412,80
25D4 positive earth (BN1-BN2)	CSD0514571 ..	€412,80
25D6 negative earth (BN4-BN6)	CSD0514582 ..	€436,80
25D6 positive earth (BN4-BN6)	CSD0514572 ..	€469,20
25D6 negative earth (BN7-BT7-BJ7)	CSD0514584 ..	€469,20
25D6 positive earth (BN7-BT7-BJ7)	CSD0514574 ..	€469,20
25D6 negative earth (BJ8)	CSD0514585 ..	€435,60
25D6 positive earth (BJ8)	CSD0514575 ..	€435,60

You must use the conventional (non-transformer) type coil with a minimum resistance of 2.5 Ohms, such as our sports coil TT2981 (3.0 Ohms), Bypass the ballast resistor if fitted. The use of a transistor type coil will damage the CSI distributor and invalidate any warranty.

Sport coil (3 ohms)	TT2981	€37,44
Sport coil, Lucas (2.8 ohms)	DLB105	€42,48



CSI PRO-IGNITION DISTRIBUTORS

CSI-PRO-Ignition distributors offer a fully electronic ignition system built into the correct type of Lucas distributor housing to suit your car, keeping the original appearance in the engine bay. You can only tell the difference when you remove the distributor cap!

Gone are the points and condenser and mechanical advance mechanism, all replaced with a high quality electronic ignition system manufactured using military specification components for durability and reliability. These distributors are maintenance free (no points to adjust), and offer the benefits of, easier starting & smoother running, more torque & power, reduced fuel consumption & emissions. They also eliminate the weaknesses of mechanical timing advance and problems such as points bounce ensuring correct ignition timing throughout the rev range.

The CSI-PRO-Ignition is a programmable distributor for your British classic car, allowing you to adjust and program the advance curves yourself. Two selectable pre-sets (modes) can be programmed, each with its own RPM and vacuum curve. Plus, various other settings such as speed limiter, maximum total advance and minimum RPM speed for activating the vacuum advance.

Edit and Write curves, even while the engine is running! The CSI-PRO-Ignition has the unique possibility to write the curves and other settings to the distributor, even while the engine is running, and to have the changes take effect immediately! The static setting (offset of 0 degrees) can also be shifted in steps of 1 degree, up to 10 degrees positive and up to 10 degrees negative, without having to rotate the distributor itself. An acceleration timer measures the time between 2 pre-set speeds to measure and compare the engine's performance. An external switch can be used for switching between the 2 modes.

With immobiliser

- 25D4 negative earth (BN1-BN2)..... CSD0533581 ... €476,40
- 25D4 dual polarity (BN1-BN2)..... CSD0533562 ... €499,20

Without immobiliser

- 25D6 negative earth (BN4-BJ7)..... CSD0533583 ... €520,80
- 25D6 dual polarity (BN4-BJ7)..... CSD0533564 ... €543,60
- 25D6 dual polarity (BJ8)..... CSD9933561 ... €474,00

The CSI-PRO can be linked with either the USB module or a Bluetooth module allowing the distributor to be programmed with a Windows laptop or an Android / iOS smartphone. Free software is provided for Window, Android and iOS.

- CSI-PRO USB programming module CSD9931 €60,96
- CSI-PRO Bluetooth programming module CSD9932 €112,08

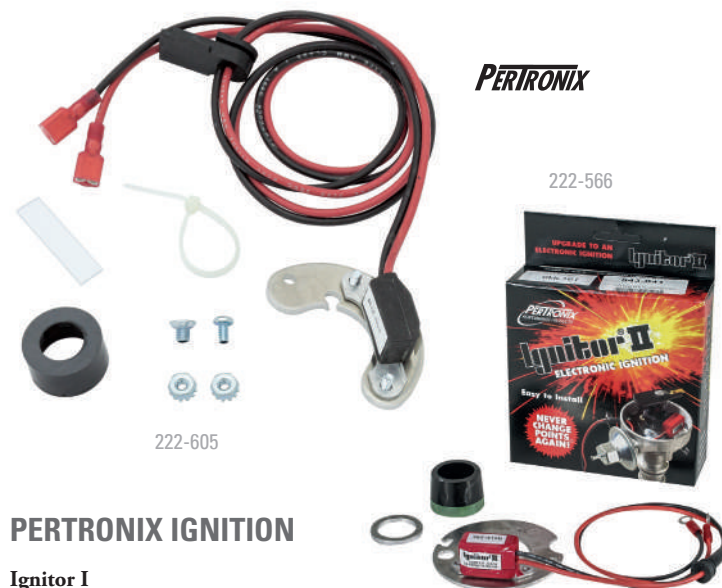

PERTRONIX IGNITION

Ignitor I

These completely self contained electronic ignition units offer a simple alternative to traditional points and condenser arrangement. Designed to fit entirely within the distributor cap they are easy to install with no external control boxes to mount and only two wires to connect, no permanent modifications are involved. The unit uses a sealed Hall Effect sensor that is impervious to dirt, dust, moisture, or vibration and retains standard advance curve. Unaffected by distributor shaft wear, maintains firing accuracy to within 1/4°, reduces spark scatter over the full rpm range. One year warranty.

100-4

- Lucas DM2, 40320 & 40422, negative earth.... 222-566 €274,80
- Lucas DM2 40320 & 40422, positive earth..... 222-567 NA
- Lucas DM2 40495 & 40520, negative earth 222-605 €290,40
- Lucas DM2 40495 & 40520, positive earth..... 222-615 €316,80

100-6 & 3000

- Lucas DM6, positive earth 222-570 €313,20
- Lucas DM6, negative earth 222-571 €259,20
- Lucas 25D6, negative earth..... 222-415 €282,00
- Lucas 25D6, positive earth 222-560 €284,40

Ignitor II

The Ignitor II has many of the same great features that the Ignitor has, but even more. The Ignitor II units sense the coil current level and use a powerful micro controller to adjust the dwell. Variable dwell helps to maintain peak energy throughout the entire RPM range. Ignitor II systems develop significantly more energy between 3000 and 5000 RPM than standard ignition systems.

- Lucas DM2, negative earth (100-4)..... 143-326 €388,80
- Lucas DM6, negative earth (100-6 & 3000) 143-327 €411,60
- Lucas 25D6, negative earth (100-6 & 3000) 143-222 NA



PERTRONIX IGNITION COILS

Pertronix Flame Thrower coils are specifically designed to work with their range of electronic contact-less ignition systems. The increased voltage gives a higher spark energy which provides more efficient burn for smoother response and better fuel economy. Available for standard & ballasted ignition systems.

Non-ballasted ignition system	143-265	€79,08
Ballasted ignition system	143-270	€79,08
Chrome bracket	143-255	€25,32



SPARK PLUGS & PLUG CAPS

NGK spark plug		
BN1, BN2, BN4, BN6, BN7, BT7	B6ES	€5,76
NGK spark plug, resistor type		
BN1, BN2, BN4, BN6, BN7, BT7	175-081	€4,92
Champion spark plug		
BN1, BN2, BN4, BN6, BN7, BT7	N5C	€8,40
BJ7, BJ8	N12YCC	€8,76
Champion spark plug, resistor type		
BN1, BN2, BN4, BN6, BN7, BT7	152-121	€4,32
BJ7, BJ8	GSP4482	€5,76

Champion cap, period style replacement	WCX600	€10,08
Lucas style cap, period style replacement	3H1422	€11,64



SMOOTHCUT REV LIMITERS

Perhaps you don't use your car flat out, but this could save an expensive bill by avoiding over-revving. The road use rev limiter comes preset for four cylinder cars to 6000rpm. It allows use of full throttle up to the limit, at which point power is gradually reduced. This unit can be preset to the customers specification; please ask for details. The competition unit is fully adjustable and works by progressively mis-timing the spark - preventing an increase in engine speed, and reducing the possibility of damage to your engine. It is suitable for 4, 6 or 8 cylinder engines.

SmoothCut rev limiter 4 cylinder preset 6000rpm	TT2987	€157,20
SmoothCut rev limiter adjustable limit	RL5	€213,36



ROTOR ARMS

Cheaper rotor arms available are prone to failing prematurely as the material is too conductive, the rivet which holds the brass inlay into the moulding is slightly longer than the original, bringing it too close to the spring clip on the underside. As a result the high tension current, averaging 30,000 volts, shorts out from the tip of the overlength rivet, through the reduced thickness of more conductive plastic via the spring clip on the underside of the rotor arm to earth out down the distributor shaft. Result - no sparks at the plugs. These Distributor Doctor rotor arms are modelled on the original, dependable 1960's design, but made from modern materials on the latest machinery to very close tolerances. These arms will not let you down. The integrally moulded brass inlay dispenses with the troublesome rivet used on most versions which is known to short circuit. The increased insulation properties of the body makes them suitable for use with high voltage coils & electronic ignition kits. The spring steel clip on the underside, in conjunction with a revised internal tolerance assures a really snug fit, even on old & slightly reduced diameter mountings.

Rotor arm, 25D4, high quality (BN1-BN2)	GRA2101HQ	€14,40
Rotor arm, 25D6, high quality (BN4-BJ8)	GRA102HQ	€14,40



WOSP HIGH TORQUE STARTER MOTOR

Give your Classic the high torque advantage! Whether you're having problems starting your engines or simply want an upgrade, our selection of high torque starter motors by WOSP perfectly meet your requirements. Manufactured in the UK, these gear reduction starters are powerful, lightweight, and built for performance. Offering increased torque, especially useful on high compression engines, these brand new, application specific starters are direct replacements built to the highest standards to withstand the rigors of all forms of motorsport. Quality and performance, WOSP starters have it all.

Features:

- All units are 100% brand new
- Based on the Denso conventional offset gear reduction design
- High power 1.0 kW and 1.4 kW Denso motors modified to suit each application and individual requirement
- Manufactured with the latest electronic testing equipment to check the performance of every product produced.

High torque starter motor (BN1-BJ8)	13H837X	€315,60
---	-------------------	---------



130-128

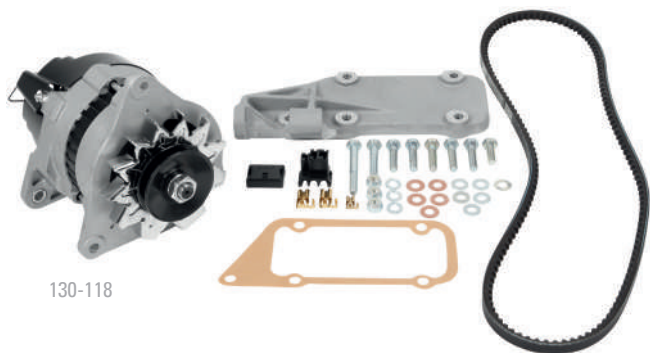

130-118

ALTERNATOR CONVERSION KIT

Whether you'd like to add a supplementary fan to your Austin-Healey's fresh air system, install a radio, power up some halogen headlamps, or simply upgrade your charging systems long term durability, converting your Healey from a generator to an alternator will be essential. Our complete alternator conversion kit makes that a simple process. This kit includes the lightweight aluminium mounting bracket/front side cover, fan belt, 45-amp alternator with cooling fan and pulley, all the necessary fittings, and a set of installation instructions.

- Alternator conversion kit (BN1-BN2) 130-128 €327,60
- Alternator conversion kit (BN4-BJ8) 130-118 €295,20

GEU6603X



GEU6607X



DUMMY CONTROL BOX VOLTAGE REGULATOR

These dummy control boxes are for use with the Wosp Performance range of 'Dynator' alternators, but can also be used with any dynamo to alternator conversion where the original voltage regulator is required for aesthetic reasons. We offer these modified control boxes in the three styles, as used originally, so you can maintain the original aesthetics of your engine bay. Each control box is fitted with an integral fuse, to protect vehicle in case of a short circuit within the existing wiring of the vehicle.

- Control box, dummy voltage regulator, screw .. 3H1835X €66,24
- Control box, dummy voltage regulator, Lucar 22 AMP. GEU6603X. €66,24
- Control box, dummy voltage regulator, Lucar 30 AMP. GEU6607X. €72,44

BATTERY CUT-OFF SWITCHES

Battery cut-off switches are a good idea for all cars. Fitting one enables you to quickly isolate the battery and immobilise the car; ideal when working on your car, or if you intend to put your car into storage.



GAC3192X

GAC31921

Battery mounted cut-off switches

These cut-off switches simply mount to the battery post and feature a screw-in knob to break the circuit. Available with a bypass fuse to allow sufficient current to pass to operate clocks, alarms and coded radios, but if any attempt is made to start the car the fuse will blow.

- Battery mounted cut-off switch GAC3192X ... €11,88
- Battery mounted cut-off switch with bypass fuse .. GAC31921.... €18,84



1B2804

1B2804L

Period cut-off switch

These are reproductions of the Lucas 'Battery Master Switch' which was a popular accessory on many British classics.

- Period battery cut-off switch (short knob) 1B2804 €54,00
- Period battery cut-off switch (long knob) 1B2804L..... €54,00



Primarily intended for competition use, this rugged switch can be used on any car. The removable key deters theft. Attached rubber cap keeps dirt and water out when the key is removed. Meets FIA requirements for motor sports.

- Racing battery switch TT7962..... €45,96



GBY3031D

GBY242D

BATTERIES

- Battery, dry, 57 A/hr, 6 volt GBY3031D..... €162,00
- Battery, dry, 73 A/hr, 12 volt GBY242D..... €314,40



BATTERY TRAY

Manufactured from high quality steel for a longer life than the original Bakelite/plastic items, which tend to become brittle over time. Finished in a thick black powder coat for added durability and resistance to corrosion or battery acid. No modifications required for installation.

Battery tray, steel (100-6, 3000 with 12V).....14G1702A €73,56



834-987

ALUMINIUM RADIATORS

Offer your classic car the benefit of a high-performance uprated brass radiator assembly. These accurate reproductions of the original Austin-Healey radiators come with an extra 25% cooling capability. They are also made with the correct fitting so that the original temperature gauge can be used. Fitted with a special core developed with extra cooling tubes and fins, invest in this very worthwhile upgrade to your cooling system.

Radiator, aluminium (BN1-BN2)..... 834-986€1.304,40
 Radiator, aluminium (BN4-BJ8)..... 834-987€962,40



235-915

235-995

OIL COOLER RADIATORS

Available in 4 sizes; 10 row for tight spaces, 13 row for most applications, 16 and 19 row for racing or other heavy duty applications.

Oil cooler, 10 row, 1/2" BSP 235-915 €78,72
 Oil cooler, 13 row, 1/2" BSP 235-925 €87,36
 Oil cooler, 16 row, 1/2" BSP 235-995€116,04
 Oil cooler, 19 row, 1/2" BSP 235-845€135,00

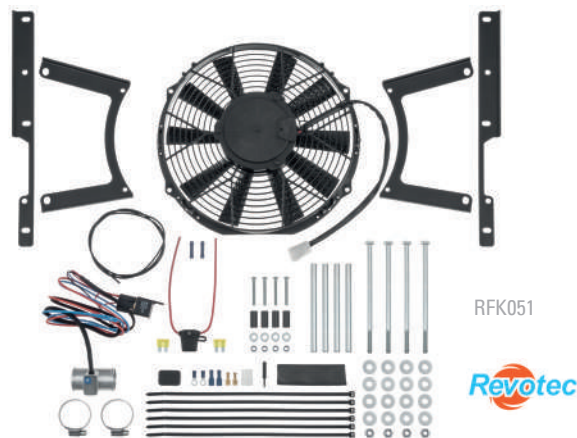

RFK051



REVOTEC FAN KITS

Keeping your car's engine running at optimum temperature will ensure you get the best performance and economy. Using the latest high efficiency fans with adjustable electronic controllers these kits are designed to replace the standard original mechanical fan, reducing the load on the engine, noise and improving both power and mpg.

Unlike other fan kits that use a universal mounting system, these Revotec kits have bespoke laser cut brackets that mount directly to the radiator mountings. The brackets are anodised to prevent corrosion. The kits also use a precise electronic controller to enable easy adjustment to suit your car. The kits include a high efficiency fan assembly, electronic controller, bespoke laser cut anodised mounting brackets, hardware & wiring & fitting instructions.

Cooling fan kit, negative earth (BN1-BN2) ... RFK051 €375,60
 Cooling fan kit, positive earth (BN1-BN2)..... RFK051P €409,20
 Cooling fan kit, negative earth (BN4-BJ8) RFK052 €334,80
 Cooling fan kit, positive earth (BN4-BJ8)..... RFK052P €416,40

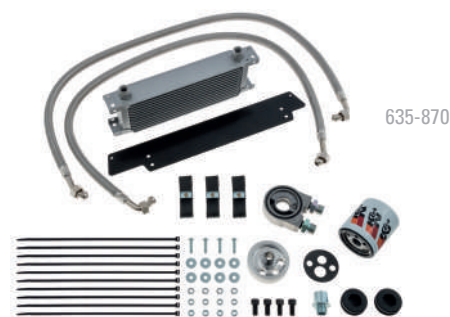

635-870

OIL COOLER KITS

Operating at the right temperature prolongs the life of your engine. In addition to lubricating, engine oil acts as a coolant by transferring heat away from critical, high-wear engine components. An engine oil cooler will lower your oil temperature and slow the viscosity breakdown of the oil while maintaining oil pressure. If you live in a hot climate or like to drive your Healey hard, our Oil Cooler Kit is a smart and relatively simple add-on to your engine. 635-810 is designed for cars already using a Moss Spin-On Oil Filter Adapter. 635-870 includes the Moss Spin-On Oil Filter Adapter.

Complete kits include hoses, adapter, 13-row oil cooler radiator and spin-on oil filter adapter.

Oil cooler kit, without spin-on filter..... 635-870 €456,00
 Oil cooler kit, with spin-on filter..... 635-810 €394,80



DYNOLITE OILS

Dynolite offers a premium quality range of lubricants and consumables developed for Veteran, Vintage & Classic cars and motorcycles.

Dynolite lubricants are formulated to exceed the original vehicle manufacturer's specifications and are blended using high quality base oils combined with additive formulations that are suitable for use in these historic vehicles.

For example, Dynolite Pre-War and Dynolite Classic engine oils include optimal levels of ZDDP to reduce wear, which is often found at reduced levels in modern engine oils.

DYNOLITE
EUROPE'S CLASSIC MOTOR OIL

Visit moss-europe.eu for more information



HIGH TORQUE STARTER MOTORS

Especially useful for high compression engines, these powerful and lightweight starter motors are a straight replacement for the original.

The benefit of their huge increase in cranking power means they are less likely to burn out under strain.

WOSP high performance starters have been available in the UK for the last 20 years. They

are built to the highest standards. Most WOSP starter units are based on a modified high power 1.4kW Denso high torque starter motor.

WOSP

See page A15 for more information



SPIN-ON OIL FILTER CONVERSION

Cleaner oil changes will result if you change your engine from the messy original canister filter to a modern spin-on filter. Each kit includes all necessary pieces for installation, filter not included.

Spin-on oil filter conversion (BN1-BJ8) 635-840 €84,24



021-119

ALUMINIUM OIL SUMP

These finned, cast aluminium oil pans improve oil cooling and help stiffen the bottom end of the cylinder block on highly stressed competition engines. The thick, smoothly machined flanges avoid the problem of oil leaks caused by bent flanges. As stock oil pan bolts are too short for use with this oil pan, replacement bolts, washers, and drain plug are included.

Shortened oil pump strainer 836-591 MUST be used with 021-119, and the oil pickup tube shortened.

Oil sump, aluminium (BN1- BN2) 021-119 €300,00

Oil sump, aluminium (BN4-BJ8)..... AEC203AL..... €422,40



OIL PUMP STRAINER

Give your engine an additional level of protection with an Oil Pump Strainer. Built with high quality materials, the strainer has a mesh screen suitable for straining large particles from the oil pan and yet passes a sufficient quantity of oil to the inlet side of the oil pump. When fitted to Austin-Healey 100-4, and when using an upgraded Moss Alloy Oil Sump (021-119), the oil pump pickup tube will need to be shortened as the alloy pan is shorter than stock.

Oil pump strainer (BN1-BN2)..... 836-591 €104,04



833-415

REAR OIL SEAL CONVERSION KIT

Permanently stop rear crankshaft oil leaks with this well-engineered lip-type oil seal conversion kit. Installation involves drilling and tapping holes in the rear of the engine block using a special drilling bush supplied. Includes instructions and all mounting hardware.

Oil seal conversion kit, 6 cylinder 833-415 €103,32

Oil seal, replacement TT1032S..... €15,36



834-887

IMPROVED COOLING FAN

Our Improved Cooling Fan has a brand new design that includes a modern-style hub for increased strength and was manufactured from a Glass filled Nylon material which is strong, rigid, and heat resistant. The fan has been balanced and the blade placement has been adjusted for a more even distribution. Fits 100-6 and 3000 model water pumps, but will fit the 100-4 model water pumps with the 834-884 adapter.

Improved cooling fan 834-887 €58,08

Adapter kit (BN1-BN2)..... 834-884 €72,60



TT2900



BAU5065M

OIL CATCH TANKS

If you modify the breather or induction systems of your car for either road or track use collection of oil should be considered. An oil catch tank is a must for competition use to prevent oil spillage on the track and it is also desirable to prevent oil vapour settling around the engine bay. These catch tanks are designed to be connected to the crankcase ventilation system, catching the oil vapour, allowing the air to vent through the special cap. Manufactured from high grade aluminium and anodised for a smart, durable finish they feature 2 x 1/2" OD connectors for the breather hoses, level indicator, breather cap and drain plug. Available in 1litre or 2 litre sizes. Mount using the rear flange to a suitable vertical panel in the engine bay.

Oil catch tank, 1lt TT2900 €243,60

Oil catch tank, 2lt TT2901 €262,80

Breather hose, 1/2" ID (per metre)..... BAU5065M €14,64

Hose clip (each)..... GHC11016..... €4,44



LAYGEARS

After many years of laygears only being available reconditioned and on an exchange-only basis, we are proud to offer these brand new replacements. They have been manufactured to the highest standard and are a direct substitute part so you will not need to change any existing internal components to fit them to your Healey.

- BN7, BT7 from (e) 29D11342 (STD) & 29D1087 (O/D)**
Laygear843-080**€592,80**
- BN7,BT7 side shift from (g) 1824 (STD) & 12320 (O/D); BN7, BT7 & BJ7 centershift**
Laygear021-251**€620,40**
- BJ8**
Laygear22B141**€592,80**

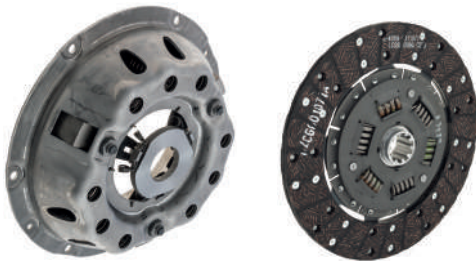

CLUTCH PLATES & COVERS

A high quality clutch disc is a very important component delivering power from engine to transmission. Upgrade your British car with one of the clutch plates from our selection.

- Clutch plates**
- BN4-BN6GCP109AF.....**€108,24**
- BN7-BT7, BJ7 to 29F-H4878GCP118**€129,72**
- BJ7 from 29F-H4879502-505 **€93,96**

High quality Borg & Beck branded clutch kits and components are the perfect upgrade for your classic car. With over 100 year's experience you can be sure the Borg & Beck brand offers premium quality components for your vehicle as well as being trusted by many leading vehicle manufacturers.

- Borg & Beck clutch covers**
- BN1-BN6, 9" diameterGCC123BB**€220,44**
- BN7-BT7, BJ7 to 29F-H4878, 10" diameter ...GCC116BB**€256,80**



COBALT CLUTCH HOSE

Offering your classic car the advantage of a stainless-steel braided clutch hose by Cobalt. High quality part available at a budget friendly price. Sold individually. Cobalt stainless steel clutch hoses provide a more direct and consistent pedal feel. They won't expand like rubber hoses can. If you are seeking performance and durability this braided steel clutch hose is a quick and easy solution that offers a noticeable improvement.

- Clutch hose, stainless steel (BN4-BJ8)584-762 **€25,56**



UPDATED CLUTCH LINKAGE

Improve your Austin-Healey clutch performance with this heavy duty clutch linkage. Made in England, this linkage is comprised of steel levers and high quality Heim joints to insure smooth, premium results. As a direct replacement for the original, this linkage should drop in easily into your BN1 or BN2, with no additional alterations necessary.

- Clutch linkage, updated (BN1-BN2)502-227**€139,92**



ALUMINIUM OFFSET CLUTCH PEDAL

Like the original, this superbly crafted clutch pedal has been manufactured from lightweight aluminium. The offset design allows for greater space between the traditionally cramped brake and clutch pedals for a more comfortable drive.

- Offset clutch pedal (BN1-BJ8)021-677 **€30,60**



POLY GEARBOX ROD BUSH KIT

Polyurethane is impervious to deterioration from the effects of ozone and is inherently far more wear resistant. Polyurethane bushes are hard enough to eliminate 90% of unwanted suspension deflection, yet remain flexible enough for a firm and quiet ride. These will outlast stock bushings by 2-3 times.

- Prothane bush kit, gearbox rod, pair280-054 **€16,44**



REAR HUB NUT SOCKET

Highly recommended for every Big Healey owner, this specially designed 8-sided socket makes working on the rear axle a breeze. Sized at 23/16" across flats, this uncommon 8-sided socket will be a great addition to any tool box. Can be used with a 1/2" drive breaker bar or 5/8" diameter Tommy Bar.

- Rear hub nut socket (BN1 from CE221536 - BJ8) 384-907 **€46,56**



TMG2930K

HIGH CAPACITY FUEL PUMPS

The standard fuel pump may not be able to maintain adequate fuel flow and pressure at higher engine speeds, particularly with a tuned engine. The Facet range of fuel pumps will suit all standard and modified engines fitted with carburettors. They give constant fuel flow and pressure, even at high temperatures eliminating the problems associated with vapour lock. The pumps are available in a variety of specifications to suit the engine's fuel pressure and flow requirements. Further fine tuning of the fuel pressure can be easily achieved by the use of a separate fuel regulator, see opposite. With safety in mind we recommend fitting a fuel pump inertia switch kit, so that in the event of an accident fuel delivery is automatically cut-off. Fuel lines may require adapting to install the new pump, check pipe sizes to select the correct unions, additional unions may be required.

Cylindrical fuel pumps

Formerly known as interrupter type pumps, these heavy duty pumps can be fitted at the front or rear of the car and up to 600mm above the bottom of the fuel tank. Kits are supplied with mounting & 8mm unions, alternative size unions available.

- Cylindrical fuel pump kit - road Silver Top TMG2930K . .€166,68 (Up to 150bhp, flow rate: 30 gal/hr, 4.0-5.50 psi, unions: 8mm x 1/8 npt).
- Cylindrical fuel pump kit - fast road Silver Top . . . MGS2930K . .€151,68 (Up to 200bhp, flow rate: 35 gal/hr, 6.0-7.0 psi, unions: 8mm x 1/8 npt).
- Cylindrical fuel pump kit - competition Red Top . . . MGS2932K . .€154,44 (Above 200bhp, flow rate: 40 gal/hr, 6.0-8.0 psi, unions: 8mm x 1/8 npt).
- Cylindrical fuel pump only - competition Red Top . . TT2930€138,96 (Above 200bhp, flow rate: 40 gal/hr, 6.0-8.0 psi, 1/4 npt threads).

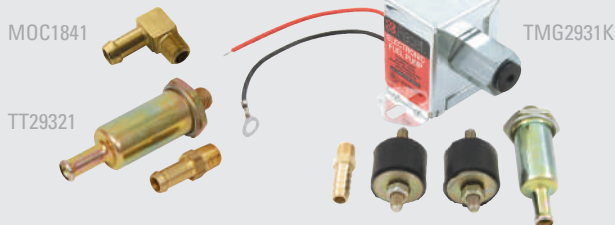

MOC1841

TMG2931K

TT29321

Solid state fuel pumps

These pumps should be mounted at the rear of the car (as they are designed to push fuel rather than draw fuel) and ideally below fuel tank level, although they will work up to 300mm above the bottom of the fuel tank. Kits are supplied with mounting & 8mm unions, alternative size unions available.

- Solid state fuel pump kit, fast road TMG2931K . .€122,88 (Up to 150bhp, flow rate; 32 gal/hr, 4.5-7 psi, unions: 8mm x 1/8 npt).
- Solid state fuel pump only, fast road MGS2931€72,00 (Up to 180bhp, flow rate: 34 gal/hr, 7.0-10.0 psi, 1/8 npt threads).

Fuel pump unions

Use with the listed fuel pumps, please check thread and pipe size before ordering.

- Straight union 1/4" (6mm) 1/8 npt FPA903B €2,88
- Straight union 5/16" (8mm) 1/8 npt MOC1604 €5,64
- Straight union 3/8" (10mm) 1/4 npt FPA904/B €4,80
- 90° union 5/16" (8mm) 1/8 npt MOC1841 €10,56
- 90° unions 5/16" (8mm) 1/4 npt (pair) TT2930A €11,88
- 90° unions 3/8" (8mm) 1/4 npt (pair) FPA902B €10,80

Fuel filter union

- Unions 1/4" (6mm) 1/8 npt (pair) TT29321 €10,80

AZX1331EN



AZX1307EN



SU ELECTRONIC FUEL PUMPS

New from SU electric fuel pumps with modern, reliable, electronic, solid state switching and control which eliminates the use of contact breaker points. Now you can have a vintage looking SU fuel pump with peace of mind that only an electronic fuel pump can offer.

BN1, BN2, BN4 to 60412

- Electronic fuel pump, negative earth AZX1331EN . €255,60
- Electronic fuel pump, positive earth AZX1332EP . €255,60
- BJ8 from 28225**
- Electronic fuel pump, negative earth AZX1307EN . €244,80

TT2927



TT2925



FUEL PRESSURE REGULATORS

We recommend the fitment of a fuel regulator which allows fine adjustment to the fuel pressure to suit your requirements. Use a filter/regulator unless you already have a fuel filter fitted.

- 67mm deep glass filter/regulator 1/4" unions TT2927 €93,24
- Replacement filter for TT2927 TT29270 €6,96
- 85mm deep glass filter/regulator 5/16" unions TT2928 €107,16
- Replacement filter for TT2928 TT29271 €12,96
- Fuel pressure regulator 1/4" unions TT2925 €98,76
- Fuel pressure regulator 5/16" unions TT2926 €98,76



BRASS FLOAT FOR FUEL SENDER UNIT

These brass fuel float alternatives will work with original Smith's sending units (will not work with early Smith units with soldered metal floats). They replace the original plastic ones and do not react to the additives used in fuels nowadays.

- Brass float, fuel tank sender unit 360-646 €16,56



ETHANOL PROOF FUEL HOSES

Modern fuels contain ethanol to help enhance the octane rating, reducing the risk of knock and pre-detonation, and tends to burn cleaner than straight petroleum. This comes at a price however, ethanol in fuel dissolves rubber fuel lines causing premature failure, and in worst case scenarios, fire due to highly flammable fuel coming into contact with possible sparking electrical wires or hot exhaust systems. As ethanol is becoming more and more prevalent in modern fuels, the need to upgrade to ethanol proof fuel hoses is obvious and essential.

Mocal Stainless Steel Braided Ethanol Proof Fuel Hoses

These fuel hoses are rated for 100psi and unlike rubber hoses, won't deteriorate with the presence of ethanol in fuel. Sold per meter.

- Fuel hose 1/4" GFH1025XB **€31,08**
- Fuel hose 3/8" GFH1037XB **€40,68**
- Fuel hose 5/16" GFH1031XB **€31,80**



GATES ETHANOL PROOF FUEL HOSES

Gates "Barricade" fuel hose can accommodate any fuel used with a conventional carburettor, and exhibits extremely low permeability.

- Compatible with ethanol, methanol and all blends of petrol and alcohol.
- Achieves five times less fuel vapour permeation than conventional hoses.
- Rated for use to 50 PSI, for any carburettor application
- Rated for temperatures from -40°C to 125°C
- Not suitable for high pressure fuel injection, can be used on the low pressure fuel return
- Sold per metre

- Gates Barricade fuel hose, 1/4" ID (per metre) . GFH1025X. **€9,84**
- Gates Barricade fuel hose, 3/16" ID (per metre) GFH1018X. **€9,36**
- Gates Barricade fuel hose, 5/16" ID (per metre) GFH1031X. **€12,24**



ALUMINIUM FUEL TANK

Lightweight aluminium fuel tank. Fits Austin-Healey 100-4 (BN1-BN2) or 100-6 BN4 (from (c)68960) to 3000 BJ8.

- Fuel tank, aluminium (BN1-BN2) 849-075 **€775,20**
- Fuel tank, aluminium (BN4 from (c) 68960 to BJ8) 11B2375A. **€700,80**



CLASSIC GOLD FUEL TANK

There have been many suppliers making Big Healey Fuel Tanks over the years, most of them being of adequate quality. Some problems were just cosmetic, other problems were more significant such as leakage. Moss' Quality team decided to put an end to all of these issues and offer this new tank. Includes the following features:

- Zinc plated steel for rust and corrosion resistance
- High quality welds
- Correct dimensions and shape
- Proper placement of the brackets for the mounting straps
- Filler neck placement and angle
- Fuel outlet size and orientation
- Properly tapped and spaced holes for sending unit
- Bung for drain plug threaded to accept the OE plug

The attention to detail in the manufacture of this tank means a quick and easy installation. An inferior, lesser quality tank will take far more time to fit. It's Zinc Coated Plate which is same as Galvanized for both side (outer and inner).

- Fuel tank, steel (BN4 from (c) 68960 to BJ8) ... 11B2375 **€408,00**



TEFLON THROTTLE SHAFT BUSH SET

Improve throttle response! Replace the original felt or rubber bushings in a loose and sluggish throttle linkage with our Teflon upgrades

- Throttle shaft bush set (BN4-BT7) 021-822 **€6,84**





370-738

100M CONVERSION PARTS

Convert your 100-4 to full 100M performance specifications. Included in the upgrade are larger dual 13/4 inch SU H6 carburetors, factory style aluminum intake manifold, alloy cold air box, duct hose, gaskets and hardware. The carburetors are period correct except for the choke levers; for a completely authentic appearance, use the standard 100-4 jet linkage.

Carburettor set, HS6, pair.....	370-738	€2.311,20
Intake manifold set.....	366-760	€346,80
Cold air box	366-770	€147,60
Air box intake hose.....	AHH5394	€33,60
Air intake hose clamp.....	14G800	€6,48
Carb insulator block.....	112866	€5,76
Cold air box badge	366-775	€18,00

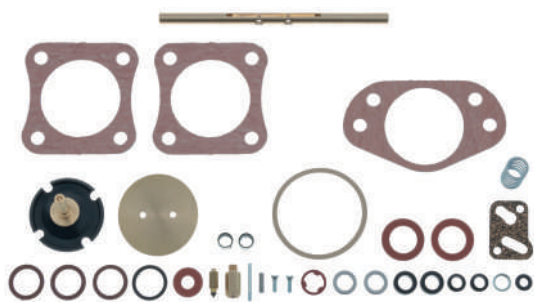

375-595

CARBURETTOR SERVICE KITS

Car not running right, a bit lumpy on idle, one carb always running a little faster than the other no matter what you do to them, a Gasket Kit could sort it, maybe the Service Kit would stand a better chance, or the Rebuild Kit and the carbs will be as good as new again.

Service kits for BN7/BT7 & BJ7 with HS4

Gasket pack, HS4	AUE811A	€9,72
Rebuild kit, HS4	375-568	€260,40
Service kit, HS4.....	375-308	€254,40

Service kits for BN7/BT7 & BJ7 with HS6

Gasket pack, HS6	AUE812A	€9,72
Rebuild kit, HS6	GAC6104X	€297,60
Service kit, HS6.....	375-318	€104,40

Service kits for BN7/BN7/BT7 & BJ8 with HD6

Gasket pack, HD6.....	AUE805	€18,24
Rebuild kit (both carbs), HD6.....	375-588	€289,20
Service kit, HD6	375-288	€197,28

Service kits for BN7/BN7/BT7 & BJ8 with HD8

Gasket pack, HD8.....	AUE806	€20,16
Rebuild kit (single carb), HD8.....	375-595	€197,28
Service kit, HD8	375-328	€183,12



370-688

GENUINE SU CARBURETTOR SETS

Genuine SU carburetors are now being produced in the UK from a combination of new and original tooling. These brand new carburetors will improve the way your car looks and runs.

HS6

Pair (100M)	370-738	€2.311,20
-------------------	---------	-----------

H4

Pair (BN1-BN2)	370-688	€2.106,00
Pair (Early BN4 2 port head).....	370-698	€2.187,60

HD6

Pair (BN4-BN6)	370-618	€2.792,40
Pair (Early BN7-BT7 to (c)29D-H2863 & 6395-18655).....	370-628	€2.792,40
Pair (Mid BN7-BT7 from (c)29D-H2864 to 6394).....	370-648	€2.792,40

HS4

Triple (BN7 & BT7 Tri-carb)	AUD18S	€2.038,80
-----------------------------------	--------	-----------

HS6

Pair (BJ7)	370-888	€1.474,80
------------------	---------	-----------

HD8

Pair (BJ8)	AUD124T	€2.989,20
------------------	---------	-----------



WEBER CARBURETTOR CONVERSION KIT

High performance DCOE carbs are still the enthusiast's choice to extract maximum power from an engine. The kit includes manifolds, linkage and carburetors with ram pipes. Rejetting and venturi changes will be necessary to get the most out of your engine. We recommend that tuning be performed by an experienced tuner. Air filters are sold separately.

Carburettor conversion kit, weber 3 x 45 DCOE ..	222-530	€3.019,20
--	---------	-----------



RAM PIPE KITS

Upgrade your classic's performance with a high-quality ram pipe kit. The short ramp pipe kit is fitted with a screen making it ideal for a street application providing additional performance and an aggressive look under the hood. Sized specifically for SU carbs. Each kit is sold per carb.

- Ram pipe kit 1 1/2" - H4, HS4 & HIF4 carbs 372-566..... €69,36
- Ram pipe kit 1 3/4" - HD6 & HS6 carbs..... 372-567..... €78,48
- Ram pipe kit 2" - HD8 & HS8 carbs 372-568..... €74,40



RAM PIPES

Ram pipes (except period style) are fitted inside the air filter to help smooth the air flow into the carburettor. The shorter the ram pipe the higher up the rev range power is produced. If using with an air filter, a minimum clearance of 1 1/2" between the ram pipe and the filter case is recommended to ensure maximum air flow.

Ram pipes for SU carburetors

- SU HS4, period style, silver, 30mm long SFR2 €30,12
- SU HS4, period style, silver, 70mm long SFR8 €30,12
- SU HS4, piper style, silver, 30mm long SFR430 €47,40
- SU HS6, period style, silver, 30mm long SFR3 €30,12
- SU HS6, period style, silver, 70mm long SFR9 €30,12
- SU HS6, piper style, silver, 50mm long SFR650 €44,64



Ram pipes for Weber carburetors

These ram pipes are genuine Weber replacement products.

- 45 DCOE, silver, 16mm long KNSS1645 €59,76
- 45 DCOE, silver, 26mm long KNSS2645 €59,76
- 45 DCOE, silver, 39mm long KNSS3945 €59,76
- 45 DCOE, silver, 60mm long KNSS6045 €48,60



CARBURETTOR BALANCER

This carburettor balancer is used to equalize the airflow between multiple carburetors.

- Flat type..... MM386-200... €58,44



WZX1177RP

OVERSIZED SHAFTS FOR SU CARBURETTORS

Worn throttle shafts and carburettor bodies cause bad idle and uneven running. This can be remedied by replacing your carburetors or by reaming out your carburettor bodies and fitting oversize throttle shafts.

- Oversize throttle shafts for HS4..... WZX1177RP . €28,92
- Oversize throttle shafts for HS6..... WZX1178RP . €28,92
- Carburettor reamer..... 386-385..... €322,80



GROSE JET FOR SU CARBURETTORS

Grose jets use a more modern ball valve so they won't stick open.

- Grose jet for SU H/HS carburetors..... GAC9201X ... €13,44



NITROPHYL CARBURETTOR FLOAT

Replace old SU-H and HD series carburettor floats that have a habit of cracking and filling with fuel with these Nitrophyl floats that won't crack or deteriorate from modern fuel additives

- Nitrophyl carburettor float..... WZX1303X... €23,16



DASHPOT COVERS FOR SU CARBURETTORS

Dashpot covers are an ideal way to enhance and brighten the engine bay. Available in classic chrome or more modern anodised finish.

- Alloy dashpot cover for HS4/HS6 SFR23 €37,08
- Anodised blue dashpot cover for HS4/HS6 SFR23B..... €37,08
- Anodised red dashpot cover for HS4/HS6 SFR23R..... €37,08
- Chrome dashpot cover for HS4/HS6..... SFR150..... €17,28
- Chrome dashpot cover short type for HS/HIF 4/6 .. SFR175 €16,56



PIPER AIR SOCKS

These air socks can be used with our piper ram pipes. They are supplied in pairs at 100mm long. They can be cut to size, though you must leave a minimum of 30mm between the inner face and the ram pipe mouth.

- Piper air socks (pair)..... PXC1050 €40,44



SU CARBURETTOR NEEDLE CHART

This needle chart gives full range of needles and their dimensions to help guide you in your choice of needles.

- SU carburettor needle chart ALT9501 €18,36



SU H-TYPE SUPERDRY JET BEARING KIT

The seals used until now have consisted of two small and one large cork seal. There is some evidence which suggests that ethanol may degrade these. A new set of rubber seals and the required new jet bearings have been

- SU H-Type (BN1, BN2, Early BN4) 370-396..... €74,52
- Superdry seal kit replacement..... 370-397..... €9,24

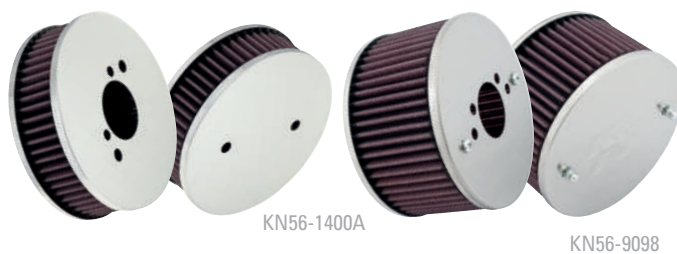

AIR FILTERS

K&N automotive replacement air filters are designed to increase horsepower and acceleration while providing exceptional engine protection. This simple to install lifetime air filter is backed by the K&N Million Mile Limited Warranty and will be the last air filter your vehicle will ever need.

K&N filters

- H-Type, without vent tube 372-086..... €200,40
- HS6, centre mount, tapered..... KN56-9327 .. €155,04
- HS6, centre mount, 45mm KN56-1400A. €148,32
- HS6, centre mount, 54mm KN56-9096 .. €148,32
- HS6, centre mount, 83mm KN56-9098 .. €129,84
- HS6, offset mount, straight..... KN56-9142 .. €126,12
- HS6, offset mount, 45mm..... KN56-9132 .. €161,76

Other air filters

- H-Type, with vent tube, BN1, BN2, BN4..... 372-095..... €98,28
- H-Type, without vent tube, BN1, BN2, BN4..... 372-085..... €215,04
- Twin HD6, front air filter..... 11B621 €54,72
- Twin HD6, rear air filter, with breather fitting ... AHB9909..... €54,72
- Triple HS4, front & centre..... AHB9023..... €54,72
- Triple HS4, rear air filter, with breather fitting ... AHB9024..... €54,72
- HS6, front..... 11B621 €54,72
- HS6, rear air filter, with breather fitting AHB9909..... €54,72
- HD8, front AHB6002..... €48,00
- HD8, rear AHB6003..... €54,72
- 1 1/2" SU carbs, vintage style, chrome, each..... 233-200..... NA

SU logo air filter

Enhance the appearance of your SU carburettors and engine bay with this chromed SU logo'd air filter. Fit 1 1/2" carburettors.

- Chrome SU logo carburettor, 1 1/2 carbs GAC1078X ... €92,52

Foam air filters

Improve performance with a traditional style chrome-plated air cleaner with washable foam filter. Sold individually.

- Oval 1 1/2" sus..... 223-220..... NA
- Round 1 1/2" sus..... 223-230..... NA
- Round 1 3/4" sus..... 37-0875..... €54,00
- Round 2" sus 37-0880..... €54,00



KNURLED SU IDLE SCREW KIT

Fine tune your idle without having to reach for a screwdriver. Made specifically for the SU carburettor, the Knurled SU Idle Screw is a quick and easy upgrade.

- Knurled SU idle screw kit 372-835..... NA

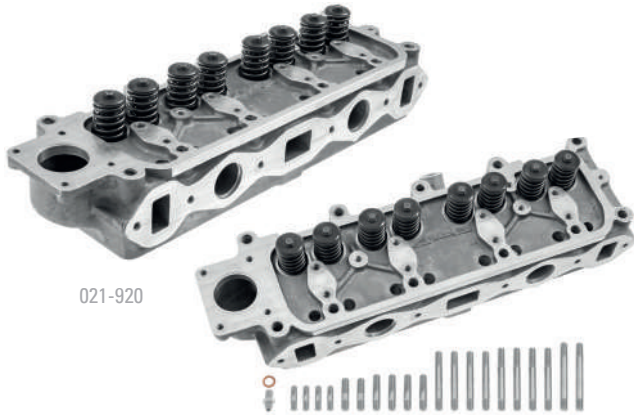

021-920

ALUMINIUM CYLINDER HEADS

Use unleaded fuel with confidence, and reduce the weight of your engine while increasing its efficiency and performance with one of these aluminium alloy cylinder heads. While these heads look like the originals externally, thin weak areas of the originals.

- BN1, BN2..... 021-920....€4.147,20
- BN4 6 port, BN6, BN7, BT7, BJ7, BJ8 021-950....€5.222,40

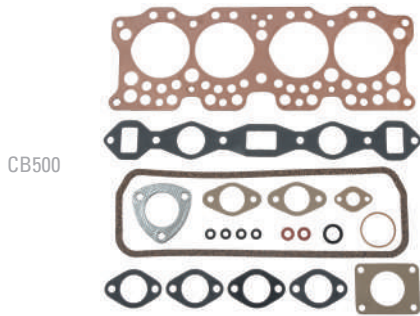

CB500

HEAD GASKET SETS

Replace the worn out gaskets with a brand new head gasket sets built specifically for your Austin-Healey.

- BN1, BN2..... CB500..... €92,64
- BN4 2 port 524-050..... €90,96
- BN4 6 port, BN6, BN7, BT7, BJ7, BJ8 GEG128 €60,00



852-095

852-100

ALUMINIUM ROCKER COVERS

An alloy rocker cover will improve the appearance of your engine bay and, as an added advantage, will help to muffle valve train noise. Always fit a new gasket when replacing your rocker cover, and do not over tighten rocker cover nuts.

- Polished rocker cover, engraved (BN1-BN2) 852-095.....€258,00
- Polished rocker cover, engraved (BN4-BJ8) 852-105.....€268,80
- Polished rocker cover, plain top (BN4-BJ8) 852-100.....€235,80

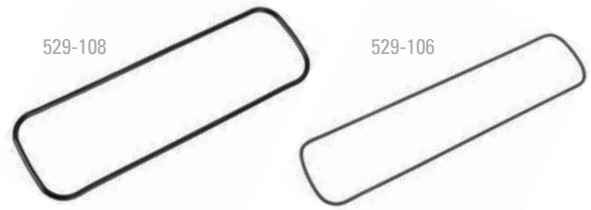

529-108

529-106

SILICONE VALVE COVER GASKETS

These premium silicone valve cover gaskets are stronger and more resilient than traditional cork. They will tolerate re-use far better as well, allowing you to remove the covers repeatedly without having to replace your gaskets each time. Two types of gaskets are offered, one for Stock covers, and one for Alloy covers. Instructions are included.

- BN1-BN2 with stock valve cover..... 529-108..... €28,68
- BN4-BJ8 with stock valve cover..... 529-104..... €39,12
- BN4-BJ8 with alloy valve cover 529-106..... €39,84



AEC27Z

ROCKER SHAFTS AND FITTINGS

Switch your damaged or worn out rocker shaft with this quality replacements with plugs.

Rocker shaft with plugs

- BN1, BN2..... 021-353..... €29,28
- BN4 2 port & 6 port, BN6, BN7, BT7, BJ7, BJ8.. AEC27Z..... €64,08

- Split pin (BN1, BN2)..... GHF502..... €1,08
- Rocker arm adjuster (BN1, BN2) 839-060..... €15,36
- Rocker pedestal without tapped hole (BN4 2 port) 021-357..... €22,08
- Spring (BN4 2 port) 031-229..... €3,48
- Rocker arm with bush BN1, BN2, BN4 2 port & 6 port, BN6, BN7, BT7, BJ7, BJ8)..... AED159 €21,96
- Rocker arm bush BN1, BN2, BN4 2 port & 6 port, BN6, BN7, BT7, BJ7, BJ8..... 11B511 €3,60
- Spring BN1, BN2, BN4 6 port, BN6, BN7, BT7, BJ7, BJ8 031-229..... €3,48



HARMONIC CRANK BALANCER

Smooth out engine vibration and reduce engine wear with this rubber insulated dampener. Many original dampeners become either delaminated with age or unbalanced due to chipping or denting. These new units produced in Australia are engineered to the highest standards, and fit all 100-6 and 3000 models.

- Crank balancer (100-6 & 3000)..... SC6622.....€585,60



AEC915

VALVES AND SPRING SETS

Get the right intake valve for your project. This is a high quality replacement for your Austin-Healey.

- Inlet valve (BN1, BN2) AEC724 €10,80
 - Inlet valve (BN4 2 port)..... 021-020..... €12,72
 - Inlet valve (BN4 6 port, BN6, BN7, BT7, BJ7, BJ8) . AEC915 €15,84
- Adding quality parts goes a long way in maintaining your British car. This valve spring set for your car comes at a reasonable price.

Valve spring set

- BN1, BN2..... 021-026..... €50,04
- BN4 2 port & 6 port, BN6, BN7, BT7, BJ7, BJ8.. 12B1344K €48,48



ARP PERFORMANCE FASTENERS

Have confidence in premium-grade 8740 chrome-moly steel with a tensile strength in the range of 200,000 psi. These studs are centreless ground with rolled threads to deliver superior performance for a rebuild that lasts.

- Head stud kit, 6 cylinder 328-876..... €297,60
- Main bearing stud kit, 6 cylinder..... 322-898..... €165,12
- Washers (16 required) 328-877..... €2,76



PINION GEAR ASSEMBLY

Invest in your Austin-Healey with a high quality pinion gear bearing assembly. Built to OE specifications, this replacement goes a long way in the upkeep of your classic car. Application specific.

- Pinion gear assembly (BN2-BN6) 021-595..... €164,88
- Pinion gear assembly (BN7-BJ8) 021-596..... €164,88



SPORTS EXHAUST SYSTEMS

Tourist Trophy manufacture some of the finest, most durable stainless steel exhaust systems available.

Tourist Trophy polished stainless steel exhaust systems are manufactured using the highest quality materials and workmanship.

These exhausts produce a distinctive 'sporty' exhaust note. Whilst the stainless steel has a mirror polish finish that shines like chrome. These systems provide a fantastic sound and look stunning.

- High quality manufacture
- Durable stainless steel resistant to corrosion
- Attractive polished appearance
- All systems are covered by a 5 year limited warranty.



See page A10 for more information



DOOR MIRRORS

Door quarter light chrome mirrors

These chrome, universal fit door mirrors are a great accessory as they clamp neatly to the quarter light and are available with a choice of rectangular or round heads. Suitable for both right hand and left hand mounting. Sold individually.

- Rectangular, bright finish, RH or LH GAM115 €36,84
- Round, 3", RH or LH GAM300 €24,96
- Round, 4", RH or LH GAM301 €21,48



WING MIRRORS

Early Lucas long arm style

Our reproduction Lucas style mirrors have chromed stems and polished stainless steel heads and are exact duplicates of the originals except the mirror retention plate lacks the Lucas name. Sold individually.

- Chrome, convex glass, RH WM1904 €24,24
- Chrome, convex glass, LH WM1905 €24,24
- Chrome, flat glass, RH WM1906 €24,24
- Chrome, flat glass, LH WM1907 €24,24
- Chrome, flat glass, cranked arm, RH or LH GAM1001X... €52,08



RAYDYOT REPRODUCTION MIRRORS

Raydyot mirrors were often bolted to racing and performance cars in the 1950s and 1960s. Their brushed aluminium design was extremely lightweight and strong. Moss has captured not only the distinctive look and character of the original Raydyot mirror, our aluminium reproductions also share the same performance advantages.

- Raydyot, alloy, flat glass 222-355 €49,20
- Raydyot, alloy, convex glass 222-356 €49,20



LONG BASE MIRRORS

These feature a 3.75" long base and are fixed with two screws from inside the door at 2" centres. Suitable for left or righthand mounting.

- Chrome, flat glass GAM105 €23,88



LONG BASE RACING MIRROR

This mirror features a larger 4.25" lens with a 3" base. It is externally fitted to the mounting bracket. Suitable for left hand or righthand mounting.

- Chrome, flat glass 222-390 €53,16



BRITISH LEYLAND STYLE MIRRORS

These feature a 3.75" long base and are plinth mounted as per British Leyland style door mirror. They are interchangeable with British Leyland type door mirror.

- Chrome, flat glass, RH GAM106 €60,48
- Chrome, flat glass, LH GAM107 €60,48
- Adaptor plate kit, RH CZH1626 €6,72
- Adaptor plate kit, LH CZH1625 €6,72



INTERIOR DASHBOARD MIRRORS

A simple, yet graceful design with a basic two screw mount, constructed entirely from stainless steel, chromed steel, and glass.

- Stainless interior dash mirror 14B1867 €28,08
- Adjustable dashboard mount mirror 165-161 €62,64



MIRROR RISER

Form follows function to help you see who is following you. The black anodised aluminium riser, complete with laser etched Austin-Healey logo lifts your mirror for a significantly improved rear view. Mounting screws included.

- Stainless interior dash mirror 165-154 €89,64



SIDE WINDSCREEN MIRROR

If you don't want to drill holes in your Healey, this is the mirror for you. Specifically designed to mount temporarily in the side screen socket and secured with an included forged wingnut, allowing quick removal when at shows or for cleaning. Measures 5" x 3 1/2" on a 5" stem. Sold individually.

BN4, BN6, BN7 & BT7 (with windscreen) 162-523..... €53,04



PERIOD FUEL CAPS

- Fuel cap, non-locking (BN1-BN2) 834-860..... €66,96
- Fuel cap, original, chrome, non-locking..... 18G8601A €10,80 (BN4-BJ8)
- Fuel cap, original, stainless steel, non-locking 18G8601SS ... €19,32 (BN4-BJ8)
- Fuel cap, period style, chrome, locking AFK1439 NA (BN4-BJ8)
- Fuel cap, Aston style..... GAC41271.... €59,88

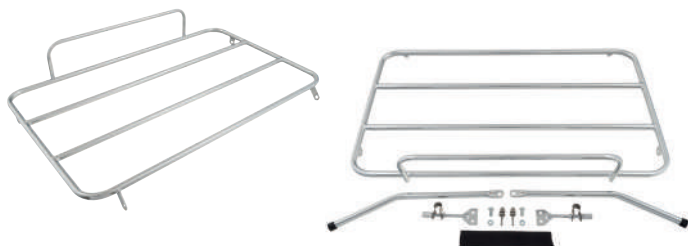

BOOT LUGGAGE RACK

This reproduction of the original factory optional luggage rack adds a distinct, vintage look to your Austin-Healey while allowing you to travel with more luggage than you would have otherwise been able to fit.

Note: Car must be fitted with OE boot hinges.

Boot luggage rack 17H9932..... €408,00



LUGGAGE STRAPS

Ratcheting tie-down strap set made from polyester webbing, ideal for securing loads or luggage safely to your boot rack. The mechanism is fitted with dipped metal 'S' hooks and has a safe working load of 60kg, (breaking strain 120kg). Available in two different lengths, 4.5m and 4m, both 25mm wide.

Luggage strap, 4m x 25mm, single..... CAR10002..... €7,44
Luggage strap, 4.5m x 25mm, pair..... CAR10003.... €20,16



GAC9973X



408-460

AUSTIN-HEALEY BADGES

Austin-Healey, enamel, toothed GAC9973X ... €41,88
RAC Healey vintage 408-460..... €83,76



CLASSIC BADGES

A range of quality badges, suitable for both grille and badge bar mounting.

- 1 BMC Drivers Club GAC9967X..... €142,92
- 2 British Motor Racing Marshalls Club GAC9987X..... €123,60
- 3 British Racing and Sports Car Club..... GAC9969X..... NA
- 4 BARC Brooklands GAC9966X..... NA
- 5 England Union flag toothed..... GAC8043X €52,56
- 6 St. Christopher GAC9970X..... €126,84
- 7 RAC diamond..... GAC9971X..... €60,72
- 8 RAC round laurel..... GAC1028X..... €95,52
- 9 RAC toothed GAC8045X..... €46,44
- 10 UK mainland..... 105-432..... €11,88
- 11 Union chequered flag (42 x 24mm) DAG000070MMM. €15,72
- 12 Union flag screw fit (30 x 50mm) GAC4100..... €17,16
- 13 Union flag screw fit (35 x 57mm), chrome .. GAC4101..... €28,68
- 14 Union flag stick on, pair CRST186..... €9,00
- 15 Union flag magnetic..... MM215-330 €17,40
- 16 Union flag 'flying' DAG000080MMM. €32,04
- 17 Union flag stick on, chrome GAC4100CR..... €19,92
- 18 GB letters stick on, chrome MRD1034SA..... €20,16
- 19 GB letters set 3 piece, chrome MRD1034A..... €18,84

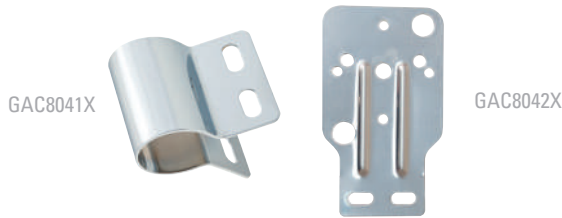

BADGE BAR & MOUNTING CLIPS

Badge bars give your classic that true period appearance. Dress up the front of your car. All our badge bars are 3/4" in diameter.

- Badge bar, chrome, with lamp brackets GAC8041X €7,08 (BN1-BN2)
- Badge bar, chrome, without lamp brackets GAC8041X €7,08 (BN4-BJ8)
- Badge bar, chrome, with lamp brackets GAC8041X €7,08 (BN4-BJ8)
- Clip, badges to grille..... GAC8042X €9,24
- Clip, badges to bar GAC8041X €7,08



CRAHK702

DECAL KITS

Finish off your restoration with one of these decal/sticker & plate sets. These decal kits contain all the plates and information decals you need for your Austin-Healey.

- Decal kit, (BN4-BN7), 1956-62..... CRAHK702... €33,96
- Decal kit, (BN7-BJ8) CRAHK701... €33,96



LUCAS STYLE HORNS

Lucas style refers to products designed to be period correct replacements of original equipment items.

- Horn, low note BHA4514..... €61,92
- Horn, high note..... BHA4515..... €61,92
- Horn mounting plate..... 57H5309..... €4,08



BONNET STRAPS

- Bonnet strap, (100M, will fit all 100-4) 221-608..... €256,80
- Fixing plate set, (100M, will fit all 100-4) 221-298..... NA
- Bonnet strap, leather, tan, pair..... 222-728..... €55,44
- Bonnet strap, leather, tan, single 222-729..... €29,28
- Bonnet strap, leather, black, pair..... 222-602..... €48,60
- Bonnet strap, leather, black, single 222-601..... €25,68



DECALS

A small selection from our range of decals available to suit your Austin-Healey, please refer to the restoration section for a listing of exact requirements for your model.

- 1 BMC rosette (external) CRTR208..... €10,08
- 2 BMC rosette (internal) CRTR204..... €10,08
- 3 BMC special tuning rosette (external) CRTR207..... €10,08
- 4 BMC special tuning rosette (internal) CRTR207A..... €10,08
- 5 Leyland Special Tuning Abingdon, green. CRST153..... €4,44
- 6 Negative earth sticker CRST113..... €2,64
- 7 Unipart filter sticker CRST119..... €2,76
- 8 Tudor water bottle sticker CRST124..... €3,48
- 9 Triplex windscreen sticker CRST125..... €3,48
- 10 British Leyland house sticker..... CRST126..... €2,28
- 11 Lucas coil sticker..... CRST156..... €3,36
- 12 Leyland Special Tuning sticker CRST110..... €3,24



BONNET & BOOT BADGES

- Bonnet badge, "100"..... 14B1724..... €18,24
- Bonnet badge, "M", with attaching wires 021-742..... €36,60
- Bonnet badge, "Austin-Healey"..... 14B1723..... €101,52
- Bonnet badge, "Austin-Healey 3000 MkII" 601-280..... €244,80
- Bonnet badge, "Austin-Healey 3000 MkIII" 021-739..... €202,80
- Bonnet badge, "100/6" 14B5772..... €23,88
- Bonnet & boot badge, "3000" AHB8861..... €17,04
- Boot badge, "Austin-Healey" 8G705 €18,12



GRILLES & SURROUNDS

Grille surrounds from the factory had either a rounded arch at the top, or two distinct angles with a flat area between. These two styles can be safely interchanged. A few of the earliest cars had a single angle apex at the top centre.

Radiator grille, (BN1-BN2)	870-050.....	€1.044,00
Round arch surround, (BN1-BN2).....	870-080.....	€489,60
Radiator grille	14B5759.....	€486,00
(BN4, BN6, BN7/BT7 to (c)13750)		
Radiator grille	AHB9000.....	€392,40
(BN7/BT7 from (c)13751, BJ7, BJ8)		
Radiator grille surround	AHB8999.....	€921,60
(BN7/BT7 from (c)13751, BJ7, BJ8)		
Air intake grille	870-120.....	€58,44
(BN4, BN6, BN7/BT7 to (c)13750)		
Air intake grille	031-349.....	€58,44
(BN7/BT7 from (c)13751, BJ7, BJ8)		
Air intake grille surround	14B5777.....	€58,44

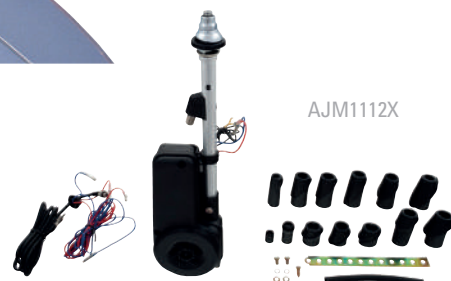
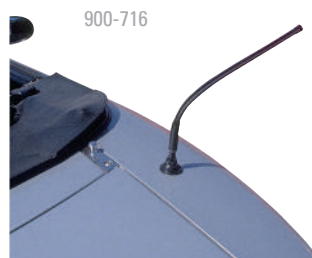

AERIALS

Upgrade your old antenna with these great replacements!

- Electric retractable aerial:** Our electric antenna kit wires into your radio for fully automatic operation. Requires 13.5" depth to mount.
 - Wing mount aerial:** This collapsible antenna locks when down. Requires 11.5" depth to mount.
 - 14" rubber aerial:** Black rubberm includes 54" aerial cable.
- | | | |
|---------------------------------|---------------|---------|
| Rubber aerial | 900-716..... | €21,96 |
| Electric aerial | AJM1112X..... | €116,16 |
| Wing mount aerial, manual | MRA001..... | €17,88 |



MINIATOR ALLOY WHEELS

Offered as an alternative to wire wheels, these MiniLite style alloys are an ideal way to add period sporting style to your classic. Available in 15" x 5.5" with a silver finish. The wheels are sold individually and are for fitment to splined hubs only.

They can be used in conjunction with our centre lock hub conversion kits to convert your conventional steel wheel rear and front hubs to accept splined hubs, enabling the fitting of either chrome wire wheels or centre lock alloy wheels. Our kits contain everything you need to convert to centre lock wheels, including full instructions, splined hubs and all the necessary hardware, chrome spinners and a copper hide mallet. Our hub conversion kits do not contain road wheels.

Silver, 8 spoke, aluminium, 5.5"x15", (3000)	GAC8255X	€318,00
Centre lock conversion kit, 2-eared, (3000)	GAC7049X.....	€432,00
Centre lock conversion kit, octagonal (3000)	GAC7050X.....	€432,00



MWS WIRE WHEELS

An essential part of a British classic sports car's styling was the fitment of wire wheels. Whether fitted as standard or not, a set of chrome wire wheels will not only enhance the appearance of your car, but also the value.

All chrome wire wheels are manufactured using stainless steel spokes and nipples.

100-4 & 100-6		
Chrome, 4"x15".....	WWC450.....	€358,80
Painted, 4"x15".....	WWP450.....	€256,80
100-4 & 100-6, disc or narrow drum & 3000		
Chrome, 5"x15".....	WWC459.....	€428,40
Painted, 5"x15".....	WWP459.....	€330,00
Chrome, 5.5"x15".....	WWC457C.....	€421,20
Painted, 5.5"x15".....	WWP457C.....	€315,60



WWC450BLO

WWP452BLO



MWS WIRE WHEEL & TYRE SETS

Wire wheels are synonymous with classic British cars, and a set of new wire wheels really enhances the look of your classic. Our range of wheel & tyre packages are assembled by the wire wheel specialists, Motor Wheel Services (MWS), and supplied as a set of 4 wheels & tyres ready to fit on your car. MWS have done the hard work for you. Each set of wheels & tyres is assembled & balanced by their tyre fitting specialists and inflated.

Balancing a wire wheel is a specialised operation and most modern tyre fitters do not have the correct balancing equipment to mount the wire wheel centre on the balancing machine. The centre needs to be mounted in the correct position to ensure that the readings on the machine are accurate and the correct balance weights are added. MWS has all the correct equipment to ensure that the wheel is perfectly balanced and ready to fit.

Please Note:

- Wheel & tyres sets are supplied with 4 wire wheels with 4 matched tyres.
- Tyres are inflated – Please refer to the workshop manual or handbook for correct tyre pressures and set accordingly.
- Spinners are not included with the tyre and wheel set.
- Unless specifically requested all wheels & tyre packages will come balanced to the inside.
- Wire wheel & tyre packages can be supplied in 4-5 days. Subject to availability.
- Original wire wheels for 100-4 and 100-6 models were 4” wide, but 4.5” or 5” can also be installed like 3000 models.

100-4 & 100-6, 48 spoke with Blockley Tyres

- Chrome, 4”x15”, 165VR15 tyres WWC450BLO .€2.150,40
- Painted, 4”x15”, 165VR15 tyres WWP450BLO .€1.736,40

100-4 & 100-6, 48 spoke with Vredestein Tyres

- Chrome, 4”x15” 165HR15 tyres WWC450VRE . €2.488,80
- Painted, 4”x15” 165HR15 tyres..... WWP450VRE .€2.172,00

3000, 60 spoke with Blockley Tyres

- Chrome, 4”x15” 165VR15 tyres WWC452BLO .€2.076,00
- Painted, 4”x15” 165VR15 tyres WWP452BLO .€1.704,00

3000, 60 spoke with Vredestein Tyres

- Chrome, 4”x15” 165HR15 tyres WWC452VRE NA

3000, 72 spoke with Blockley Tyres

- Black, 5”x15” 165VR15 tyres WWB459BLO .€1.935,60
- Chrome, 5”x15” 165VR15 tyres WWC459BLO .€2.382,00
- Painted, 5”x15” 165VR15 tyres WWP459BLO .€1.869,60
- Stainless steel, 5”x15” 185VR15 tyres..... WWS459BLO .€3.420,00
- Chrome, 5.5”x15” 185/70VR15 tyres WWC457BLO .€2.737,20
- Painted, 5.5”x15” 185/70VR15 tyres WWP457BLO .€2.324,40

3000, 72 spoke with Vredestein Tyres

- Black, 5”x15” 165HR15 tyres..... WWB459VRE .€2.262,00
- Chrome, 5”x15” 165HR15 tyres WWC459VRE .€2.757,60
- Painted, 5”x15” 165HR15 tyres..... WWP459VRE .€2.214,00
- Stainless steel, 5.5”x15” 165HR15 tyres..... WWS459VRE. .€3.832,80



AHA7374

107948/3

88G606

PLAIN WHEEL SPINNERS

All our centre lock wheel spinners are made from the highest quality materials and are precision engineered to ensure an accurate fit. We have 3 different styles to choose from - octagonal, 2 eared, or 3 eared. Two and three eared spinners can be fitted with a hammer or spanner, octagonal spinners require a spanner. Please check local regulations for eared spinners. Sold individually.

2-eared, 12 tpi, RH	AHH7317	€40,80
2-eared, 12 tpi, LH	AHH7318	€40,80
2-eared, 8 tpi, RH	AHA7373	€46,92
2-eared, 8 tpi, LH	AHA7374	€46,92
3-eared, 12 tpi, RH	AHH73173	€75,36
3-eared, 12 tpi, LH	AHH73183	€75,36
3-eared, 8 tpi, RH	107948/3	€80,40
3-eared, 8 tpi, LH	107949/3	€80,40
Octagonal, 12 tpi, RH	AHH7315	€35,16
Octagonal, 12 tpi, LH	AHH7316	€40,08
Octagonal, 8 tpi, RH	88G606.....	€37,80
Octagonal, 8 tpi, LH	88G607.....	€37,80



Disc wheel hub cap 031-312..... €69,84



WHITE WALL TRIMS

A popular accessory in the past were white wall tyres, unfortunately if you can find them now they tend to be made for the US market and of a much harder compound than European tyres. However, we are able to supply a rubber ring which is sandwiched between the wheel rim and the tyre wall, recreating the look of white wall tyres but allowing the use of quality modern tyres.

Measurements:

- Seating lip: 10mm
- Black section: 20mm
- White section: 12mm

White wall trim, 15” wheels, set..... GLZ227WWX4 ... €84,12



221-645

- Spare wheel strap, (BN1, BN2) 221-645..... €117,12
- Spare wheel strap, (BN6, BN7) 221-675..... €83,40
- Spare wheel strap, (BN4, BT7, BJ7, BJ8)..... 14B6771..... €42,48



TT6902

WHEEL SPACERS

These spacers will allow small adjustments to be made to the offset (to ensure wheel and tyre clearance) when fitting alloy wheels. Can also be used to space your wheels out to fit your arches. When choosing the width of the spacer, ensure that it will leave adequate thread length for secure wheel fitment.

- Spacer, 3mm, pair TT6901 €28,44
- Spacer, 6mm, pair TT6902 €28,44



BTC108

WIRE WHEEL HUBS

- Front, RH, (BN1) 1B4320 €135,36
- Front, LH, (BN1) 1B4321 €135,36
- Front, RH, (BN2, BN4, BN6, some late BN1) .1B4478. €140,40
- Front, LH, (BN2, BN4, BN6, some late BN1) .1B4481. €140,40
- Front, RH, (BN7, BT7, BJ7, BJ8 to (c)26704) .BTC108. €147,96
- Front, LH, (BN7, BT7, BJ7, BJ8 to (c)26704) .BTC109. €147,96
- Front, RH, (BJ8 from (c)26705) BTC390 €148,56
- Front, LH, (BJ8 from (c)26706) BTC391 €148,56

Wire wheel hub extensions BN1 from C.E.221536, BN2-BJ8 to (c)26704

- RH, ATC7236 €77,88
- LH, ATC7237 €77,88

Wire wheel hub extensions BJ8 from (c)26705

- RH, BTC406 €77,88
- LH, BTC407 €77,88

452-755



WIRE WHEEL INNER TUBES

Using the correct size of inner tube will reduce tube failures and heat build-up within the tyre. Creating an air tight seal on a wire wheel can be somewhat difficult, making inner tubes necessary. To prevent the spoke nipples from piercing or chafing the tube, the fitting of a rim band is highly recommended.

- Inner tube, 15" for 155/165 tyres 452-755 €24,96
- Inner tube, 15" for 175/185 tyres 452-765 €39,96
- Rim band, 15" 452-750 €24,00



7H1805CP

7H1805

WIRE WHEEL SPOKES

Replacement wire wheel spokes to fit 100-3000 4"x15" wire wheels (WWC/WWP450).

- Chrome, stainless steel, 6.45", outer 7H1805CP €10,80
- Chrome, stainless steel, 5.01", outer 7H1806CP €10,80
- Mild steel, 6.45", outer 7H1805 €6,48
- Mild steel, 5.01", outer 7H1806 €6,48

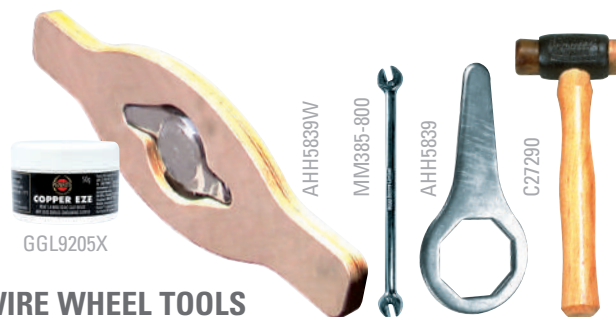

WIRE WHEEL TOOLS

The use of a soft-faced hammer is essential if you do not want to damage chrome plated spinners when removing or fitting centre lock wheels. We have a choice of three soft hammers. Extra long spanners are also available, providing much greater leverage for spinners and therefore easier fitting. To help keep your wire wheels looking like new we recommend you use our specialist cleaning kit. We also supply a special lubricant to help keep the splines in good condition.



- Hammer, copper & hide C27290 €49,32
 - Hammer, copper faced, 453g (1lb) 386-000 €30,60
 - Hammer, copper faced, 907g (2lb) 11B5166 €43,32
 - Spanner, spoke adjusting MM385-800 ... €17,52
 - Spanner, short, octagonal AHH5839 €10,20
 - Spanner, long, octagonal MM386-120 ... €84,84
 - Spanner, long, 2-eared MM386-125 ... €83,52
 - Wrench, wooden, 2-eared AHH5839W .. €30,60
- (This unique double ended knock-off wrench, made from plywood, slips over the spinner for easy tightening and removal of spinners. Will not work with centre laced wheels).
- Cleaning kit, wire wheels GAC4134X ... €45,00
 - Spline lubricant, copper-eze, 50g GGL9205X €6,00
- (Essential for maintaining the splines and threads of hubs, wheels and spinners).

MM225-715



TYRE GAUGE

Solid brass, precision gear movement. Push button valve to bleed air to the desired pressure. US and metric scales.

- Brass tyre gauge MM225-715 ... €19,20



VALVE CAPS

Dress up your chrome wheels with a classic touch. These solid brass caps with logos are finished in chrome and utilize an O-ring for a proper seal. Sold as a set of 4.

- Union Jack, non-locking 37-9087 €20,76
- Checkerboard, non-locking 101-167 NA

171-250



H4 LED HEADLAMP CONVERSION

Developed for H4 (Semi-Sealed) style headlamps, the Stella Lux LED conversion represents a technological breakthrough for classic car owners. Lighting levels of 3000 Lumens per bulb mean these can be up to three times brighter than a standard H4 halogen bulb. LEDs emit a bright white 6000K colour and deliver vastly improved road presence and visibility for a safe confident driving experience, no matter the conditions. The kit includes a pair of premium quality 25W Lumileds Luxeon Z ES LED H4 light units with a 10,000+ hour lifespan, and low load plug-and-play dual polarity drivers. We also offer this kit with two H4 style WIPAC headlamps. Keep your classic styling and have better lighting; you get the best of both worlds with this easily installed upgrade..

Headlamp conversion, H4, LED 171-250.....€145,92



PERIOD STYLE LAMPS

These outstanding reproductions of the original Lucas L576 units are available as either a driving lamp with a clear lens or a fog lamp with a fluted lens in either a base or back mounting. Use a back mounted fluted lamp as a works style reverse lamp.

Driving lamp with clear lens, each MM162-701..€122,88
 Front fog lamp with fluted lens, each MM162-800..€122,88
 Back mounted lamp with fluted lens, each BHA4399....€122,88
 Back mounted lamp with clear lens, each 57H5322.....€122,88

Don't worry if your spot or fog lamp gets damaged we stock replacement glass lamp units, so you don't have to buy the whole lamp again.

Replacement lamp unit, fluted lens, each ACG5179..... €57,24
 Replacement lamp unit, clear lens, each..... 57H5015..... €59,64
 Replacement bulb driving lamp, each..... GLB185 €6,96
 Replacement bulb fog lamp, each GLB323 €9,00



HEADLAMP PEAKS

Headlamp peaks, pair..... GAC7999X ... €22,56



DRIVING & FOG LAMPS

These high quality driving lamps are styled to replicate the BMW Mini driving lamps. Manufactured in stainless steel they are ideal as replacements for corroded original items but can be retro-fitted to using brackets detailed below. Their retro styling means they will complement most classic cars and the universal mounting brackets allow easy Fitting using the universal wiring kit.

Driving lamp, set..... GAC4619..... €82,56

Quality reproductions of the classic Lucas style SFT lamp from the 50's and 60's. Approximately 5" in diameter. Driving lamps have clear, plain lenses, fog lamps have fluted lenses.

Driving lamp, back mounted, single..... 57H5322.....€122,88
 Fog lamp, back mounted, single..... BHA4399....€122,88

Wipac 5.5" chrome plated driving & fog lamps

Driving lamps, base mounted, Wipac, pair WPS6007..... €54,24
 Fog lamps, base mounted, Wipac, pair..... WPS6078..... €54,24
 Wiring kit..... GAC4027..... €19,80
 Bulb, H3 replacement GLB453 €6,24



H4 HALOGEN HEADLAMP CONVERSIONS

Fitting modern halogen headlamps is one of the most worthwhile safety improvements you can make to your classic. Powerful halogen bulbs combined with improved lens design, result in a superior light beam and pattern. Replacement lens units are available, please see page 82 in the Restoration section.

Wipac quad optic kits

No pilot, RHD, pair GAC4022..... €73,32
 No pilot, LHD, pair MGE203..... €96,60
 With pilot, RHD, pair..... GAC4023Z ... €84,60
 With pilot, LHD, pair WPS4699..... €99,84

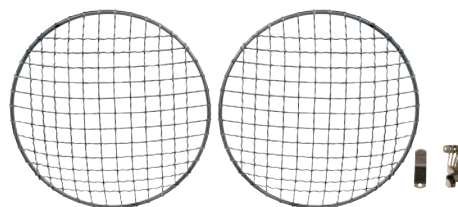

CHROME HEADLAMP STONE GUARDS

Add some protection to your headlamps with these period chrome guards.

Headlamp stone guards, clip fit, pair GAC8000X ... €19,20



506370X

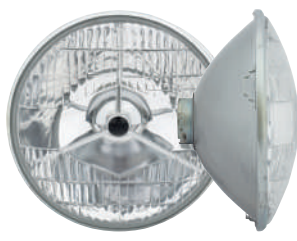

LU554308

TRIPOD HEADLAMPS

Original equipment on early British cars. These Tripod style headlamps can be retro fitted to any suitable classic, but expect a reduction in light output. Suitable for period drives in the country on a warm summers evening. Tripod headlamps use BPF bulbs.

- Tripod headlamp assembly, RHD, each. 506370X..... €190,20
- Tripod headlamp assembly, LHD, each. 506372X..... €138,84
- Tripod lamp unit, RHD, each LU554308 ... €147,36
- Tripod lamp unit, LHD, each LU555296 ... €128,88
- Replacement bulb, RHD, each..... GLB414 NA
- Replacement bulb, LHD, each..... GLB415 €13,44



222-129

COMPETITION HEADLAMP BLANKS

Give your Classic the racer look with our brand new competition headlamp blanks. Crafted for racing enthusiasts, as many competitions require the removal of the headlights, these blanking plates are designed to fit in place of the original 7" headlamp units. Perfect for racing and off-road use, these lightweight, quality aluminium headlamp blanks are available in two options. Take your pick from a plain brushed aluminium blanking plate or one with a decal simulating a Lucas P700 light! Easy to install. Sold individually.

- Headlamp blank 222-128..... €34,20
- Headlamp blank, with decal 222-129..... €47,64



HEADLAMP PROTECTORS

A thin, invisible layer of Lamin-X protects headlamps from stone chips and scratches, and keeps your lights looking new for years to come. Fits all 7" round headlamps. Sold as a pair. Lamp unit not included.

- Headlamp protectors, pair 162-695..... €27,36



DRIVING LAMP CLAMP

These beautifully chromed and polished clamps are intended to mount 500 and 700 series fog or driving lamps, a standard 3/4" badge & lamp bar, or even antennas and other accessories. They are ideal to mount spot and fog lamps and some badges. The mounting hole diameter is 0.62".

- Lamp clamp, chrome 408-579..... €22,80



HEADLAMP RIM

Give your classic that individual look with these alloy rim in anodised silver. Supplied individually.

- Headlamp rim, aluminium, each 500929ALLOY .. €43,44



GAC4608

GAC4609

AUXILIARY REVERSE & FOG LAMPS

Many classics were not originally fitted with reverse or rear fog lamps. These universal polished stainless steel lamps measure 55mm x 110mm (2" x 4.5" approx.) and can be easily fitted, ideal for mounting under bumpers etc... Fog lamps require an illuminated switch mounted visibly on the dashboard.

- Auxiliary fog lamp..... GAC4608 €28,92
- Auxiliary reverse lamp GAC4609 €31,56
- Bulb replacement 12V 20W, each..... GAC4608B..... €5,28
- Toggle switch..... RTC430A €7,44

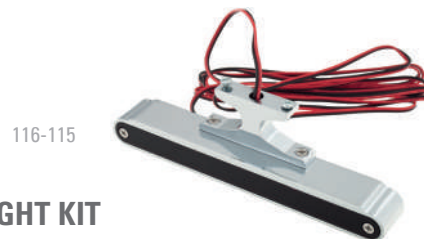

116-115

THIRD BRAKE LIGHT KIT

Center-mounted 3rd brake lights reduce accidents, so much so that they have been required on all passenger autos built since 1984. Our older classics, which are equipped with two dim, low mounted brake lights, aren't exactly easy to see. With a little creative wiring, you can mount one of our brilliant accessory 3rd brake light kits and improve the safety of your British classic. The base can be removed for flush mounting.

- 3rd brake light kit, chrome 116-115 €101,28



1

2

3

GENERAL SWITCHES

A range of period looking switches for general purpose use. Use a momentary switch for starters, horns, washers, and the 1 position for auxiliary lamps.

- 1 Push button switch, momentary 3H3058..... €17,88
- 2 Toggle switch, momentary GWW102X €27,60
- 3 Toggle switch, on/off..... RTC430A..... €7,44
- Pull switch, on/off, white illumination GAE132 €35,16
- 4 Pull switch, on/off, green illumination GAE132G €35,16
- Pull switch, on/off, red illumination GAE132R..... €35,16
- Pull switch, on/off, yellow illumination.... GAE132Y €35,16
- Fuse holder inline UKC4446..... €3,24



BEZEL REMOVAL TOOL SET

The round bezels on most Lucas Switches have two slots, and nobody has the special tool you need to take them off. Using a screwdriver results in a scratched dash and colourful language. These tools have two teeth for the slots in the bezels and are made from hard steel so the teeth will last; critical for this application so you don't mar your bezels. The set includes tools for 3/4" diameter and 1" diameter bezel nuts.

Bezel removal tool set..... 384-960..... €28,68



ELECTRONIC FLASHER UNIT

If you are upgrading any of your indicators to LED bulbs, then you will need to upgrade to an electronic flasher unit. The LED bulbs draw such little power that they struggle to make a mechanical indicator flash.

2 terminal GFU2124XL.. €21,24
 3 terminal GFU2103XL.. €23,04



TOWING EYE KIT

031-426

To meet Canadian requirements, these towing Eyes were originally fitted to BJ7s from approximately January 1963 (H-BJ7-20880 on) and all BJ8s. While intended to facilitate towing, these additions were quickly recognized as ideal tie-down brackets when transporting with a trailer. Because the holes selected for the towing eyes are in the same relative location on every Healey frame, these brackets will fit on every big Healey made from the BN1 through the BJ8. These are black-powder coated for an original look and durability. We also have a set of towing eye/tiedown brackets for the rear (#267-522).

Towing eye kit, front, (BN1-BJ8) 031-426..... €39,48
 Towing eye kit, rear, (BN1-BJ8 to (c)26704) 267-522..... €48,96



117-515

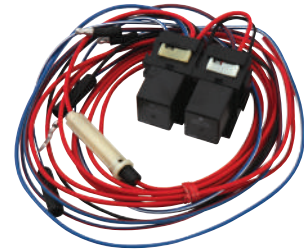

HEADLAMP RELAY KITS

Fitting halogen headlamps puts high loads on electrical components. These kits allow easy installation of relays into the headlamp circuit allowing for the high current circuit to be run through the relay. Fitting relays in headlamp circuits protects your wiring and reduces the resistance in the circuit allowing full power to the lamps. Kits include relays and fittings. The single relay kit can also be used for wiring spotlamps, horns and other electrical accessories.

Relay kit, headlamp, 2 relay 117-515..... €55,08
 (Inc: 2 relays, pre-wired relay holders, fitted terminals, fittings & instructions).
 Relay kit, headlamp 1 relay GAC4027..... €19,80
 (Inc: 1 relay, non-assembled wiring, terminals & fittings).
 PVC tubing, black, pre cut, metre..... 504806 €3,48



NUMBER PLATE LAMP WIRING HARNESS

This license plate lamp harness incorporates an inline fuse that effectively prevents a short in the license plate lamp from impacting the vehicles entire wiring harness. This was a common problem for all Austin-Healey's from the beginning of production in 1953 to late BJ8 (B.85964) when the issue was at last addressed. This harness provides a quick and inexpensive solution to what could become a very major problem.

Number plate lamp wiring harness, with fuse..... 356-375..... €19,80





CAR COVERS

Protecting your cherished classic with a car cover will help to keep the paint, hood and brightwork in the best possible condition and safe from the elements. Whether you need a cover to keep the dust off your car whilst in your garage, a lightweight cover to take to the shows and occasional use, or a cover that provides weather protection for cars kept outside all year round. Moss has the perfect car cover to fit your car!

Weatherproof outdoor covers

Our range of outdoor weatherproof car covers are manufactured from breathable fabrics. They feature double-stitched seams throughout, with neoprene elastic sewn into the front and rear hems. Fitted with reinforced, scratch-proof grommets for tying down. Note: No car cover is completely waterproof. Simply choose the fabric to suit your requirements: Mosom Plus or Ultimate.

Mosom Plus outdoor cover

Our range of Mosom outdoor weatherproof car covers are manufactured from breathable fabrics with double-stitched seams. The Mosom Plus is rain resistant, yet breathable and features a multi-layer polypropylene fabric which remains soft and pliable in all weather conditions with a soft lining. Fitted with reinforced, scratch-proof grommets for tying down. Recommended for short-term outdoor use.

Car cover, Mosom Plus..... GAC2011X ..€156,12

Ultimate outdoor cover

Ultimate car covers by Classic Additions use a specially formulated advanced nanotechnology formula which gives a unique water resistant coating ensuring long term protection for your classic. Fully waterproof, fully breathable, strong and stretchy. Manufactured in a discrete grey colour these car covers are suitable for use both indoors and outdoors.

Car cover, Ultimate outdoor, size S1 GAC95041...€325,20



MM240-150

WIND WINGS

These large, clear plexiglass panels are mounted to adjustable chrome fixing brackets. Installed without drilling, and compatible with side curtains. Sold in pairs.

Wind wings, pair..... MM240-150... €92,64



24B635/6

SIDE SCREENS

Sidescreen, pair, (BN4-BT7) 24B635/6€462,00



700896

'BROOKLANDS' AEROSCREEN

These Aeroscreens are a faithful replica of the classic 'Brooklands' Aeroscreens. Made from laminated safety glass, with a polished aluminium frame and supplied with chrome plated fittings and mounting stems. You will also need 4 screws to fix them to the scuttle.

Aeroscreen, with stems, each 700896€134,52
 Screw, Aeroscreen to scuttle, each, 4 req..... AD608063 €0,96
 Aeroscreen stem kit, replacement, pair 700896FK..... €16,80
 Screw, attachment..... 602078 €18,84



GAC9224X

SMARTSCREEN WASH/WIPER SYSTEM

These SmartScreen wiper kits allow intermittent wiper delay of between three and thirty seconds, programmed by using your existing wiper switch. SmartScreen wash/wiper kit allows you to have an automatic wiper system when using your electric screen-wash. All kits are easy to fit and come with full instructions.

SmartScreen wiper system

Positive earth GAC9222X ... €45,00
 Negative earth, converted GAC9224X ... €45,00
 Negative earth GAC9221X ... €45,00

SmartScreen wash/wiper system

Negative earth models, 1967 on..... GAC9225X ... €75,72



021-858

TRIPLEX GLASS FROM PILKINGTON CLASSICS

Give your classic a concourse level restoration with Triplex Glass from Pilkington Classics. Offering the best of quality and fit, these come with period correct Triplex markings. Application specific and built to last, they are now offered by Pilkington Glass for the first time since these cars went out of production. Sold individually.

Door glass, LH (BJ7-BJ8) 021-858..... €261,60
 Door glass, RH (BJ7-BJ8) 021-859..... €261,60
 Windscreen (BN1-BN2)..... 14B1862OE.. €444.00
 Windscreen (BN4-BT7) 14B5891OE .. €388.80
 Windscreen (BJ7-BJ8) AHB9424OE. €457.20



300-330

CRUSH GRAIN, EVERFLEX VINYL & STAYFAST CANVAS HOODS

Our hoods are manufactured to the exact original specifications and patterns, and are available in several different materials. Stayfast cloth, Everflex vinyl and Crush grain vinyl tops are made by Robbins Auto Top Company in the U.S.A. The Everflex Vinyl hood material is made in England by the original manufacturer and imported by Robbins, and are as close to original as possible. All necessary fasteners are included with each hood.

Stayfast cloth is engineered for high tensile and tear strength, but the fabric stays soft, supple with tightly controlled stretch characteristics to ensure that hoods do not sag or otherwise lose their shape. Stayfast cloth resists fading and shrinking better than vinyl and does not stiffen up at lower temperatures.

Everflex vinyl is the original material from England. Black and blue Everflex now have a grey inner lining, while tan has a tan lining. If you want your hood to be as close to original as you can get, this is the material to consider.

Crush grain vinyl is the best American vinyl with a subtle random grain pattern. Uses Haartz Supreme 36-oz. pinpoint-grain vinyl (backed with pre-shrunk cotton cloth).

Crush grain vinyl (BN1, BN2)

Crush grain vinyl, black.....	300-330.....	€823,20
Crush grain vinyl, tan.....	300-332.....	€823,20
Crush grain vinyl, white.....	300-333.....	€823,20

Everflex vinyl (BN1, BN2)

Everflex vinyl, black.....	300-370.....	€1.092,00
Everflex vinyl, tan.....	300-372.....	€1.092,00
Everflex vinyl, white.....	300-373.....	€1.092,00

Stayfast cloth (BN1, BN2)

Stayfast cloth, black.....	641-001.....	€1.087,20
Stayfast cloth, blue.....	641-002.....	€1.087,20
Stayfast cloth, tan.....	641-003.....	€1.087,20
Stayfast cloth, red.....	641-004.....	€1.087,20

Crush grain vinyl (BN4 to C.E 68959)

Crush grain vinyl, black.....	300-335.....	€790,80
Crush grain vinyl, tan.....	300-337.....	€790,80
Crush grain vinyl, white.....	300-338.....	€790,80

Everflex vinyl (BN4 to C.E 68959)

Everflex vinyl, black.....	300-375.....	€982,80
Everflex vinyl, blue.....	300-376.....	€889,20
Everflex vinyl, tan.....	300-377.....	€982,80
Everflex vinyl, white.....	300-379.....	€982,80

Stayfast cloth (BN4 to C.E 68959)

Stayfast cloth, black.....	300-400.....	€1.202,40
Stayfast cloth, blue.....	300-401.....	€1.202,40
Stayfast cloth, tan.....	300-402.....	€1.202,40
Stayfast cloth, red.....	300-404.....	€1.202,40

Crush grain vinyl (BN4 from C.E 68960, BT7 to C.E 1528)

Crush grain vinyl, black.....	300-340.....	€799,20
Crush grain vinyl, tan.....	300-342.....	€799,20
Crush grain vinyl, white.....	300-343.....	€799,20

Everflex vinyl (BN4 from C.E 68960, BT7 to C.E 1528)

Everflex vinyl, black.....	021-527.....	€880,80
Everflex vinyl, blue.....	641-020.....	€538,80
Everflex vinyl, red.....	300-382.....	€700,80
Everflex vinyl, tan.....	300-383.....	€700,80
Everflex vinyl, white.....	300-384.....	€700,80

Stayfast cloth (BN4 from C.E 68960, BT7 to C.E 1528)

Stayfast cloth, black.....	641-021.....	€969,60
Stayfast cloth, blue.....	641-022.....	€969,60
Stayfast cloth, tan.....	641-023.....	€969,60
Stayfast cloth, red.....	641-024.....	€969,60

Crush grain vinyl (BN6, BN7)

Crush grain vinyl, black.....	300-350.....	€705,60
Crush grain vinyl, tan.....	300-352.....	€705,60
Crush grain vinyl, white.....	300-353.....	€705,60

Everflex vinyl (BN6, BN7)

Everflex vinyl, black.....	021-529.....	€538,80
Everflex vinyl, blue.....	641-010.....	€579,60
Everflex vinyl, red.....	300-405.....	€538,80
Everflex vinyl, tan.....	300-349.....	€538,80
Everflex vinyl, white.....	300-406.....	€538,80

Stayfast cloth (BN6, BN7)

Stayfast cloth, black.....	641-011.....	€876,00
Stayfast cloth, blue.....	641-012.....	€876,00
Stayfast cloth, red.....	641-014.....	€876,00
Stayfast cloth, tan.....	641-013.....	€876,00

Crush grain vinyl (BT7 from C.E. 1529)

Crush grain vinyl, black.....	300-345.....	€778,80
Crush grain vinyl, red.....	640-145.....	€780,00
Crush grain vinyl, tan.....	300-347.....	€778,80
Crush grain vinyl, white.....	300-348.....	€778,80

Everflex vinyl (BT7 from C.E. 1529)

Everflex vinyl, black (BT7 from C.E. 1529) ..	300-385.....	€974,40
Everflex vinyl, tan (BT7 from C.E. 1529)	300-387.....	€974,40
Everflex vinyl, white (BT7 from C.E. 1529) ..	300-388.....	€877,20

Stayfast cloth (BT7 from C.E. 1529)

Stayfast cloth, black.....	641-031.....	€969,60
Stayfast cloth, blue.....	641-032.....	€969,60
Stayfast cloth, tan.....	641-033.....	€969,60
Stayfast cloth, red.....	641-034.....	€969,60

Crush grain vinyl (BJ7 to (B)59371)

Crush grain vinyl, black.....	300-355.....	€507,60
Crush grain vinyl, tan.....	300-357.....	€507,60
Crush grain vinyl, white.....	300-358.....	€507,60

Everflex vinyl (BJ7 to (B)59371)

Everflex vinyl, black.....	021-531.....	€879,60
Everflex vinyl, blue.....	300-391.....	€879,60
Everflex vinyl, red.....	300-407.....	€879,60
Everflex vinyl, tan.....	300-392.....	€879,60
Everflex vinyl, white.....	300-408.....	€879,60

Stayfast cloth (BJ7 to (B)59371)

Stayfast, black.....	641-061.....	€1.060,80
Stayfast, blue.....	641-062.....	€1.060,80
Stayfast, tan.....	641-063.....	€1.060,80
Stayfast, red.....	641-064.....	€1.060,80

Crush grain vinyl (BJ7 from (B)59372 & BJ8)

Crush grain vinyl, black.....	300-360.....	€620,40
Crush grain vinyl, tan.....	300-362.....	€620,40
Crush grain vinyl, white.....	300-363.....	€620,40

Everflex vinyl (BJ7 from (B)59372 & BJ8)

Everflex vinyl, black.....	300-395.....	€904,80
Everflex vinyl, tan.....	300-397.....	€904,80
Everflex vinyl, white.....	300-410.....	€904,80

Stayfast cloth (BJ7 from (B)59372 & BJ8)

Stayfast cloth, black.....	641-071.....	€1.060,80
Stayfast cloth, blue.....	641-072.....	€1.060,80
Stayfast cloth, red.....	641-074.....	€1.060,80
Stayfast cloth, tan.....	641-073.....	€1.060,80

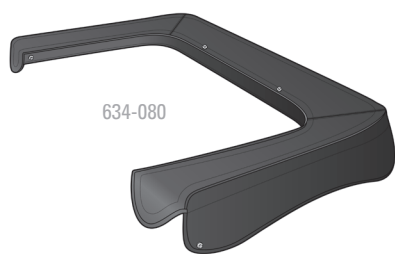

634-080

HOOD STOWAGE COVERS

Our hood stowage covers are manufactured to the exact original specifications in vinyl and in the correct colours. We have the BJ8 stowage covers in Stayfast cloth, as well.

Hood stowage covers (BJ7)

Vinyl, black (BJ7)	643-080.....	€343,20
Vinyl, blue (BJ7)	643-110.....	€343,20
Vinyl, red (BJ7)	643-105.....	€343,20
Vinyl, white (BJ7)	643-100.....	€343,20

Hood stowage covers (BJ8)

Stayfast, black (BJ8)	643-091.....	€1.080,00
Stayfast, blue (BJ8)	643-092.....	€1.080,00
Stayfast, tan (BJ8)	643-093.....	€1.080,00
Vinyl, black (BJ8)	643-090.....	€328,80
Vinyl, blue (BJ8)	643-130.....	€343,20
Vinyl, tan (BJ8)	643-120.....	€698,40

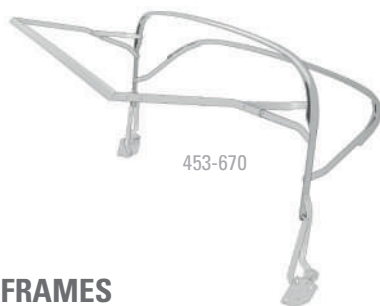

453-670

HOOD FRAMES

The hood frame is the key to purchasing the correct hood for your Austin-Healey. Many of the hood frames are interchangeable, and many times the previous owners have changed them out, much to the amazement and chagrin of the current owner. Never assume your hood frame is original.

Hood frame (BN1, BN2).....	453-670.....	€375,60
Hood frame (BN4 to C.E. 68959).....	453-675.....	€375,60
Hood frame (BN6, BN7).....	SC1619.....	€399,60
Hood frame (BT7 from C.E. 1529).....	453-667.....	€470,40



226-105

LIFT THE DOT HAND PUNCH

For professional installers, this tool would make a fine car club tool box addition. Punches centre hole and prong holes for installation of Lift-the-Dot fasteners to make installation of hoods and tonneau-covers a cinch.

Lift the dot punch	226-105.....	€104,16
Sock and clinch plate, single.....	LFS100S.....	€2,64



234-005



234-000

GEAR KNOBS

Our gear knobs are just the right size and feel, and made of elegant walnut wood or trimmed in black leather and topped with a medallion displaying the Austin-Healey logo. The gear knob is designed with a hard plastic insert that accommodates a range of gear lever sizes and thread widths. By applying pressure on the gear knob while twisting it onto the lever, the plastic insert will thread and firmly secure itself. Prior to installing the gear knob, screwing on a jam nut is recommended. When the gear knob is positioned where you want it, tighten the jam nut to the base.

Gear knob, leather, black	234-005.....	€21,36
Gear knob, wooden.....	234-000.....	€20,40



GLB987LN

LED DASH BULBS

Give your classic car the benefit of LED dash bulbs. Bright white LED dash bulbs illuminate your gauges very well and are a replacement for the standard incandescent bulb (GLB987). LEDs burn cooler and last much longer than standard incandescent bulbs! LED light is not dimmable. LEDs should not be used as turn signal indicators or for the red alternator light on the dash. Sold individually.

Negative ground	GLB987LN ...	€13,32
Positive Ground	GLB987LP.....	€9,84



GLOVE BOX LOCK

After many years of these Austin-Healey BJ8 Glove Box Locks being virtually impossible to find, we located a quality source and are now able to offer them. These are a high quality, made as original with push button opening and includes two keys.

Glove box lock (BJ8)	633-740.....	€124,32
----------------------------	--------------	---------



AHH7010

CIGAR LIGHTER KIT

To replace a defective original, or add an electrical outlet to earlier cars. This kit includes a complete illuminated lighter assembly as fitted to many classic & modern cars.

Cigar Lighter kit	AHH7010	€29,28
Bracket	AHH7010BKT.	€8,76



BHA4737



1B9061Z

GAUGES

This genuine Smith's combination gauge is a direct replacement for the obsolete originals. Gauge has black face with white lettering and needles, and a 82" capillary tube. Fits from BN4 C.E.72850, BN6 (c)2030 through BJ8. Lettering and the scales may differ from the instrument in your car.

Gauge, oil pressure/water temperature BHA4737 **€189,48**
(BN4 C.E.72850, BN6 (c)2030 through BJ8)

Aftermarket replacement gauges

Fuel gauge, (BN1, BN2) 3H3064Z **€209,64**
Fuel gauge, (BN4-BJ7)..... 1B9061Z..... **€202,80**

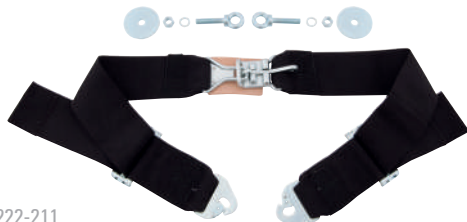

222-211

VINTAGE COMPETITION LAP BELT

Quick release buckle, complete with mounting hardware. Sold individually. Note: These seatbelts are not 'E' marked therefore should only be used in cars that pre-date seat belt regulations.

Lap belt, tan buckle pad, each 222-211..... **€160,80**
Lap belt, black buckle pad, each..... 222-221..... **€160,80**



489-040

489-060



489-020

489-080



489-050

489-090

TOURIST TROPHY STEERING WHEELS & BOSSES



Designed to complement your classic, these wheels are handcrafted to high standards. Available with the choice of either a sporty leather rim or a classic riveted wood rim with a variety of spoke designs and finishes; drilled or slotted in either matt alloy or black. The frames are made from high strength aluminium.

Leather rim, black drilled spokes, 14"489-040 **€195,00**
Leather rim, alloy, drilled spokes, 15"489-020 **€195,00**
Leather rim, alloy, drilled spokes, 14"489-030 **€195,00**
Leather rim, black slotted spokes, 15"489-050 **€195,00**

Laminated wood rim, alloy, drilled spokes, 15" ... 489-060 **€244,80**
Laminated wood rim, alloy, drilled spokes, 14" ... 489-070 **€244,80**
Laminated wood rim, matt alloy, slotted spokes, 14" .489-085 **€244,80**
Laminated wood rim, matt alloy, slotted spokes, 15". 489-080. **€244,80**

Solid thick wood rim, alloy, drilled spokes, 14"489-095 **€244,80**
Solid thick wood rim, alloy, drilled spokes, 15"489-090 **€244,80**



454-298

Adaptor bosses

The boss kits include a die cast alloy boss, and a horn push with a high quality chrome and enamel badge bearing a marque emblem. The centre cap/horn push is also available separately to fit existing Moto-Lita bosses.

Boss kit, 46mm (BN1-BJ8)..... 454-298 **NA**
Austin-Healey centre cap, plastic 905-648 **€44,52**
Austin-Healey centre cap, billet aluminium 905-654 **€110,04**
Badge replacement 905-686 **€24,48**



MLW1115-13

MLW1112-13

MOTO-LITA STEERING WHEELS *Moto-Lita*

Moto-Lita are among the finest replacement steering wheels available. Designed to enhance the appearance of the cockpit and provide an improved feel for the driver.

Available in a variety of styles, materials and sizes to suit, please see our website for the full list of options. All steering wheels listed feature drilled spokes, except where detailed.

Wood rimmed steering wheels

- Mk3, flat, polished spokes, 13" MLW1115-13 .. €322,80
- Mk3, flat, polished spokes, 14" MLW1115-14 .. €322,80
- Mk3, flat, polished spokes, 15" MLW1115-15 .. €322,80

- Mk3, dished, polished spokes, 13" MLW1116-13 .. €322,80
- Mk3, dished, polished spokes, 14" MLW1116-14 .. €322,80
- Mk3, dished, polished spokes, 15" MLW1116-15 .. €322,80

- Mk3, flat, polished spokes, thin slots, 14" MLW1120-14 .. €322,80
- Mk3, flat, polished spokes, thin slots, 15" MLW1120-15 .. €322,80

- Mk3, flat, polished spokes, wide slots, 13" MLW1122-13 .. €322,80
- Mk3, flat, polished spokes, wide slots, 14" MLW1122-14 .. €322,80
- Mk3, flat, polished spokes, wide slots, 15" MLW1122-15 .. €322,80

- Mk3, dished, polished spokes, thin slots, 13" ... MLW1125-13 .. €322,80
- Mk3, dished, polished spokes, thin slots, 14" ... MLW1125-14 .. €322,80
- Mk3, dished, polished spokes, thin slots, 15" ... MLW1125-15 .. €322,80

Leather trimmed steering wheels

- Mk4, flat, polished spokes, 12" MLW1111-12 .. €351,60
- Mk4, flat, polished spokes, 13" MLW1111-13 .. €351,60
- Mk4, flat, polished spokes, 14" MLW1111-14 .. €351,60
- Mk4, flat, polished spokes, 15" MLW1111-15 .. €351,60

- Mk4, flat, black spokes, 13" MLW1112-13 .. €351,60
- Mk4, flat, black spokes, 14" MLW1112-14 .. €351,60
- Mk4, flat, black spokes, 15" MLW1112-15 .. €351,60

- Mk4, dished, polished spokes, 12" MLW1113-12 .. €351,60
- Mk4, dished, polished spokes, 13" MLW1113-13 .. €351,60
- Mk4, dished, polished spokes, 14" MLW1113-14 .. €351,60
- Mk4, dished, polished spokes, 15" MLW1113-15 .. €351,60

- Mk4, dished, black spokes, 13" MLW1114-13 .. €351,60
- Mk4, dished, black spokes, 14" MLW1114-14 .. €351,60
- Mk4, dished, black spokes, 15" MLW1114-15 .. €351,60

- Mk4, flat, polished spokes, thin slots, 13" MLW1121-13 .. €322,80
- Mk4, flat, polished spokes, thin slots, 14" MLW1121-14 .. €322,80
- Mk4, flat, polished spokes, thin slots, 15" MLW1121-15 .. €322,80

- Mk4, dished, polished spokes, thin slots, 13" ... MLW1126-13 .. €322,80
- Mk4, dished, polished spokes, thin slots, 14" ... MLW1126-14 .. €322,80
- Mk4, dished, polished spokes, thin slots, 15" ... MLW1126-15 .. €322,80

Mahogany rimmed steering wheels

- Mk9, flat, polished spokes, thin slots, 14" MLW1119-14 .. €450,00
- Mk9, flat, polished spokes, thin slots, 15" MLW1119-15 .. €450,00

- Mk9, flat, polished spokes, holes, 14" MLW1119-14H €450,00
- Mk9, flat, polished spokes, holes, 15" MLW1119-15H €450,00



MLW1117B6



905-686

Moto-Lita

MOTO-LITA BOSSES & ACCESSORIES

The adjustable column steering wheel hub is fitted with a hand nut and collet allowing the wheel to slide in and out.

Adjustable Column: The adjustable boss, which comes with a new hand nut and collet, is designed to be used with an original style control head (horn/turn signal switch). If for some reason you do not intend to use a control head, the horn push can be used to cover the resulting hole. (Please Note. The horn push cannot be made operational).

Non-Adjustable Column: The non-adjustable hub is supplied without any horn push or cover for the centre. It is designed to use the horn push as a non-operational cover. The hub can however be easily machined to accept the original control head.

- Boss, non-adjustable column MLW1117B6... €144,60
- Boss, adjustable column..... MLW1117B7... €228,12
- Centre cap, Austin-Healey, plastic 905-648 €44,52
- Centre cap, Austin-Healey, billet aluminium... 905-654 €110,04
- Badge, replacement..... 905-686 €24,48
- Ring kit, polished MLW1117X3... €23,28
- Ring kit, black MLW1117X3B .. €42,48



222-315

223-610

WHEELSKINS STEERING WHEEL COVER

We're pleased to offer the finest steering wheel cover we've ever seen! Unlike adjustable covers, this premium grade black leather cover is custom tailored to fit. Simple installation results in a quality factory-fitted appearance appropriate for the discriminating enthusiast. The look and feel of fine leather under your hands will make driving a delight!

Choose the width that matches your wheel by measuring the outside diameter and then the circumference of the grip.

- Black, dia: 15"-16", Grip: 2 3/4"-3 1/8" 223-610 €102,12
- Black, dia: 16 1/2"-17"; Grip: 2 3/8" 222-310 €102,12
- Black, dia: 16 1/2"-17"; Grip: 2 1/2" 222-315 €102,12



247-235



VINYL & LEATHER ARMRESTS

In order to restore the interior of your Austin-Healey to its original quality, we manufacture early Healey upholstery kits in our own Upholstery Shop with an eye on quality control every step of the way. We use only the finest materials in our kits; our leather is tanned and vat-dyed to the highest standards to ensure durability. Our vinyl's have been selected for their colour & grain style. Each piece is cut by our skilled craftsmen using patterns painstakingly developed by us.

Armrests (BN1)

Leather - black/black piping	247-235	€160,68
Leather - black/red piping	247-255	€160,68
Leather - black/white piping	247-245	€160,68
Leather - blue/white piping	247-287	€160,68
Leather - honey tan/honey tan piping	247-297	€160,68
Leather - red/black piping	247-276	€160,68
Leather - red/red piping	247-265	€160,68
Leather - red/white piping	247-275	€160,68
Leather - tan/tan piping	247-295	€160,68
Vinyl - black/black piping	247-165	€135,84
Vinyl - black/red piping	247-185	€135,84
Vinyl - black/white piping	247-175	€135,84
Vinyl - blue/blue piping	247-215	€135,84
Vinyl - blue/white piping	247-217	€135,84
Vinyl - honey tan/honey tan piping	247-227	€135,84
Vinyl - red/black piping	247-206	€135,84
Vinyl - red/red piping	247-195	€135,84
Vinyl - red/white piping	247-205	€135,84
Vinyl - tan/tan piping	247-225	€135,84

Armrests (BN2 to BN4 (c)68959)

Leather - black/black piping	247-230	€159,00
Leather - black/red piping	247-250	€159,00
Leather - black/white piping	247-240	€159,00
Leather - blue/blue piping	247-280	€159,00
Leather - honey tan/honey tan piping	247-292	€159,00
Leather - red/black piping	247-271	€159,00
Leather - red/red piping	247-260	€159,00
Leather - red/white piping	247-270	€159,00
Leather - tan/tan piping	247-290	€159,00
Vinyl - black/black piping	247-160	€128,52
Vinyl - black/red piping	247-180	€128,52
Vinyl - black/white piping	247-170	€128,52
Vinyl - blue/blue piping	247-210	€128,52
Vinyl - blue/white piping	247-216	€128,52
Vinyl - honey tan/honey tan piping	247-222	€128,52
Vinyl - red/black piping	247-201	€128,52
Vinyl - red/red piping	247-190	€128,52
Vinyl - red/white piping	247-200	€128,52
Vinyl - tan/tan piping	247-220	€128,52

Armrests (BN4 from (c)68960 & BJ7)

Leather - black/black piping	247-370	€101,52
Leather - black/red piping	247-390	€101,52
Leather - black/white piping	247-380	€101,52
Leather - blue/blue piping	247-420	€101,52
Leather - blue/white piping	247-425	€101,52
Leather - honey tan/honey tan piping	247-432	€101,52
Leather - red/black piping	247-405	€101,52
Leather - red/red piping	247-400	€101,52
Leather - red/white piping	247-410	€101,52
Leather - tan/tan piping	247-430	€101,52
Vinyl - black/black piping	247-300	€121,44
Vinyl - black/red piping	247-320	€121,44
Vinyl - black/white piping	247-310	€121,44
Vinyl - blue/blue piping	247-350	€121,44
Vinyl - blue/white piping	247-355	€121,44
Vinyl - honey tan/honey tan piping	247-362	€121,44
Vinyl - red/black piping	247-345	€121,44
Vinyl - red/red piping	247-330	€121,44
Vinyl - red/white piping	247-340	€121,44
Vinyl - tan/tan piping	247-360	€121,44

Armrests (BJ8 to (c) 26704)

Leather - blue/blue piping	247-781	€146,52
Leather - black/black piping	247-760	€146,52
Leather - dark blue/dark blue piping	247-780	€146,52
Leather - red/red piping	247-770	€146,52
Leather - tan/tan piping	247-790	€146,52
Vinyl - blue/blue piping	247-741	€117,24
Vinyl - black/black piping	247-720	€117,24
Vinyl - dark blue/dark blue piping	247-740	€117,24
Vinyl - red/red piping	247-730	€117,24
Vinyl - tan/tan piping	247-750	€117,24

Armrests (BJ8 from (c) 26705)

Leather - blue/blue piping	247-861	€135,36
Leather - black/black piping	247-840	€135,36
Leather - dark blue/dark blue piping	247-860	€135,36
Leather - red/red piping	247-850	€135,36
Leather - tan/tan piping	247-870	€135,36
Vinyl - blue/blue piping	247-821	€106,20
Vinyl - black/black piping	247-800	€106,20
Vinyl - dark blue/dark blue piping	247-820	€106,20
Vinyl - red/red piping	247-810	€106,20
Vinyl - tan/tan piping	247-830	€106,20

246-600



FRONT & REAR SEAT COVER KITS

Restore the interior of your Austin-Healey to its original design and high standards with Moss handcrafted Front and Rear Seat Kits. Manufactured in our own upholstery shop, these kits have been patterned from the early Healey upholstery kit samples, and made by skilled craftsmen with the aid of modern technology for exacting standards. With an eye on quality-control every step of the way, we have used only the finest materials in our seat kits. Our leather is tanned and vat-dyed to ensure durability, and the vinyls have been selected for their color and grain style. We're so confident in the quality of our upholstery items that we guarantee 100% satisfaction or your money back upon return of the uninstalled kit.

Front seat kits (BN1-BN4 to C/E68959)

Leather - black/black piping	246-670	€816,00
Leather - black/red piping	246-690	€816,00
Leather - black/white piping	246-680	€816,00
Leather - blue/blue piping	246-720	€816,00
Leather - honey tan/honey tan piping	246-732	€816,00
Leather - red/black piping	246-715	€816,00
Leather - red/red piping	246-700	€816,00
Leather - red/white piping	246-710	NA
Leather - tan/tan piping	246-730	€816,00

Vinyl - black/black piping	246-600	€478,80
Vinyl - black/red piping	246-620	€478,80
Vinyl - black/white piping	246-610	€478,80
Vinyl - blue/blue piping	246-650	€478,80
Vinyl - honey tan/honey tan piping	246-662	€478,80
Vinyl - red/black piping	246-645	€478,80
Vinyl - red/red piping	246-630	NA
Vinyl - red/white piping	246-640	€478,80
Vinyl - tan/tan piping	246-660	€478,80

Rear seat kits (BN4 to C/E68959)

Leather - black/black piping	246-670	€816,00
Leather - black/red piping	246-690	€816,00
Leather - black/white piping	246-680	€816,00
Leather - blue/blue piping	246-720	€816,00
Leather - honey tan/honey tan piping	246-732	€816,00
Leather - red/black piping	246-715	€816,00
Leather - red/red piping	246-700	€816,00
Leather - red/white piping	246-710	NA
Leather - tan/tan piping	246-730	€816,00

Vinyl - black/black piping	246-600	€478,80
Vinyl - black/red piping	246-620	€478,80
Vinyl - black/white piping	246-610	€478,80
Vinyl - blue/blue piping	246-650	€478,80
Vinyl - honey tan/honey tan piping	246-662	€478,80
Vinyl - red/black piping	246-645	€478,80
Vinyl - red/red piping	246-630	NA
Vinyl - red/white piping	246-640	€478,80
Vinyl - tan/tan piping	246-660	€478,80

Front seat kits (BN4 from C/E68960 to BJ7)

Leather - black/black piping	246-815	€840,00
Leather - black/red piping	246-835	€840,00
Leather - black/white piping	246-825	€840,00
Leather - blue/blue piping	246-862	NA
Leather - honey tan/honey tan piping	246-877	€840,00
Leather - red/black piping	246-856	€840,00
Leather - red/red piping	246-865	€840,00
Leather - red/white piping	246-855	€840,00
Leather - tan/tan piping	246-875	€840,00

Vinyl - black/black piping	246-740	€472,80
Vinyl - black/red piping	246-760	€472,80
Vinyl - black/white piping	246-750	€472,80
Vinyl - blue/blue piping	246-790	€472,80
Vinyl - honey tan/honey tan piping	246-802	€472,80
Vinyl - red/black piping	246-785	€472,80
Vinyl - red/red piping	246-770	€472,80
Vinyl - red/white piping	246-780	€472,80
Vinyl - tan/tan piping	246-800	€472,80

Rear seat kits (BN4 from C/E68960 to BT7)

Leather - black/black piping	246-955	€390,00
Leather - black/red piping	246-975	€432,00
Leather - black/white piping	246-965	€432,00
Leather - blue/blue piping	247-005	€432,00
Leather - honey tan/honey tan piping	247-017	€390,00
Leather - red/black piping	246-996	€432,00
Leather - red/red piping	246-985	€432,00
Leather - red/white piping	246-995	€432,00
Leather - tan/tan piping	247-015	€390,00

Vinyl - black/black piping	246-885	€228,48
Vinyl - black/red piping	246-905	€228,48
Vinyl - black/white piping	246-895	€228,48
Vinyl - blue/blue piping	246-935	€228,48
Vinyl - honey tan/honey tan piping	246-947	€228,48
Vinyl - red/black piping	246-916	€228,48
Vinyl - red/red piping	246-915	€228,48
Vinyl - red/white piping	246-925	€228,48
Vinyl - tan/tan piping	246-945	€228,48

Rear seat kits (BJ7)

Leather - black/black piping	247-090	€472,80
Leather - black/red piping	247-110	€472,80
Leather - black/white piping	247-100	€472,80
Leather - blue/blue piping	247-140	€472,80
Leather - honey tan/honey tan piping	247-152	€472,80
Leather - red/black piping	247-135	€472,80
Leather - red/red piping	247-120	€472,80
Leather - red/white piping	247-130	€472,80
Leather - tan/tan piping	247-150	€472,80

Vinyl - black/black piping	247-020	€230,88
Vinyl - black/red piping	247-040	€230,88
Vinyl - black/white piping	247-030	€230,88
Vinyl - blue/blue piping	247-070	€230,88
Vinyl - honey tan/honey tan piping	247-082	€230,88
Vinyl - red/black piping	247-065	€230,88
Vinyl - red/red piping	247-050	€230,88
Vinyl - red/white piping	047-060	NA
Vinyl - tan/tan piping	247-080	€230,88

Front seat kits (BJ8)

Leather - black	247-510	€1.027,20
Leather - Austin-Healey blue	247-551	€1.027,20
Leather - dark blue	247-550	€1.027,20
Leather - light tan	247-570	€1.027,20
Leather - red	247-530	€1.027,20
Vinyl - black	247-540	NA
Vinyl - Austin-Healey blue	247-491	€634,80
Vinyl - dark blue	247-490	€634,80
Vinyl - light tan	247-500	€634,80
Vinyl - red	247-470	€634,80

Rear seat kits (BJ8)

Leather - black	247-650	€741,60
Leather - Austin-Healey blue	247-691	€741,60
Leather - dark blue	247-690	€741,60
Leather - light tan	247-710	€741,60
Leather - red	247-670	€741,60

Vinyl - black	247-590	€728,40
Vinyl - Austin-Healey blue	247-631	€579,60
Vinyl - dark blue	247-630	€728,40
Vinyl - light tan	247-640	€728,40
Vinyl - red	247-610	€728,40



COMPLETE VINYL PANEL KITS

Crafted to match the original designs, these vinyl panel kits give your interior a professional appearance even when installed by a novice. There is no easier way to erase years of wear and tear from your interior than to fit one of our beautiful panel kits! For unmatched durability, we use plywood and waterproof panel board as original. Each kit includes front kick panels and door panels.

100-4 (inc. spare tyre cover)

Black	247-880	€570,00
Red	247-890	€570,00
Blue	247-900	€570,00
Tan	247-910	€570,00
Honey tan	247-912	€570,00

100-6 (BN4 to C/E68959)

Black	247-925	€742,80
Red	247-935	€742,80
Blue	247-945	€742,80
Tan	247-955	€742,80
Honey tan	247-957	€742,80

100-6 (BN4 from C/E68960) - 3000 BT7

Black	247-965	€885,60
Red	247-975	€885,60
Blue	247-985	€885,60
Tan	247-995	€885,60
Honey tan	247-997	€885,60

100-6 (BN6) - 3000 (BN7)

Black	247-960	€954,00
Red	247-970	€954,00
Blue	247-980	€954,00
Tan	247-990	€954,00
Honey tan	247-992	€954,00

3000 (BJ7)

Black	248-000	€577,20
Red	248-010	€577,20
Blue	248-020	€577,20
Tan	248-030	€577,20
Honey tan	248-032	€577,20

3000 (BJ8 to (c)26704 Mkl & MkII)

Black	248-040	NA
Red	248-050	€714,00
Austin-Healey blue	248-061	€714,00
Dark blue	248-060	€714,00
Light tan	248-070	€714,00

3000 (BJ8 from (c)26705 MkIII)

Black	248-080	€714,00
Red	248-090	€714,00
Austin-Healey blue	248-701	€714,00
Dark blue	248-700	€714,00
Light tan	248-710	€714,00

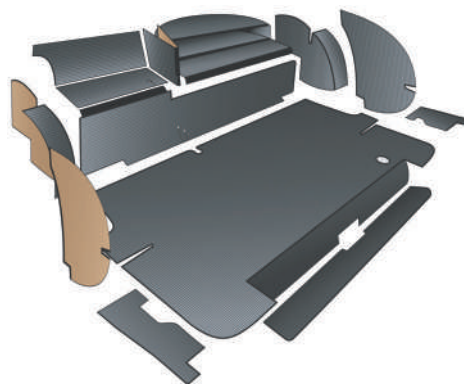

BOOT LINER SETS

Complete your restoration with one of our tailored boot liner sets. This kit has been developed with the help of two members of the Austin-Healey Concours Registry's Committee, and is guaranteed to be the most authentic boot kit available for Austin-Healey. Includes illustrated installation instructions. Supplied in black Armacord only.

Boot liner kit (BN1, BN2)	249-912	€334,80
Boot liner kit (BN6, BN7)	249-920	€457,20
Boot liner kit (BN4-7, BT7, BJ7, BJ8)	249-930	€256,80

240-492



FOOTWELL MATS

Custom tailored plush embroidered mats look great at a great price and fit perfectly. Edges are bound for a tidy look. Rubber ribbed backing keeps the mats in place. Austin-Healey wings logo embroidery is approx. 7" wide.

Footwell mats, plush, black, pair	240-492	€101,52
---	---------------	---------

Custom tailored for a perfect fit, these mats are made with an ultra-dense plush carpet and non-slip rubber backing. Features embroidered logos.

Footwell mats, ultra plush, black, pair	240-491	€175,08
---	---------------	---------

Protect your carpets from dirt, wear and fading. If mats get dirty, clean them and fit them back on your car.

Footwell mats, rubber, black, pair	AM6817-2	€46,68
--	----------------	--------



680-950

HEEL MAT

Heel mat for Austin-Healey carpet set, included in carpet sets.

Heel mat, black, rubber, single	680-950	€19,32
---------------------------------------	---------------	--------

248-720



COMPLETE CARPET SETS - LHD

Renew your interior with Moss upholstered carpet sets, rated highly for quality and authenticity. The reason they are the most authentic in the market is because we've consulted with the foremost experts in Austin Healey restoration and Concours Committee to make sure our materials, patterns and techniques are as true to original as possible. Each complete kit includes the correct rubber heelmat and all necessary snaps and studs.

100-4 – We offer two carpet sets for the 100-4. For those interested in the original look, you'll want our carpet and Armacord kit. Armacord used to match the color of the carpet, but is only available in black today. The current solution is to dye the Armacord to match the red, blue or honey tan carpet. This is common practice and one that has been performed on boot liner kits for years. If you're interested in a custom look, we also have an all carpet version (not in black) to upgrade your interior to carpet throughout.

100-6 & 3000 – We offer a choice of original style or deluxe. The original style is exactly that, made in every way to original specifications with correct binding. Our deluxe kit includes a bound edged 2-piece tunnel carpet with a flap for the transmission dipstick access.

100-4 (BN1) - All carpet

Black	NA
Red	248-730 €547,20
Blue	248-740 €547,20
Honey Tan	248-735 €547,20

100-4 (BN1) - Carpet with black Armacord

Black	248-720 €520,80
Red	248-731 €520,80
Blue	248-741 €523,20
Honey Tan	248-736 €520,80

100-4 (BN2) - All carpet

Black	NA
Red	248-760 €554,40
Blue	248-770 €554,40
Honey Tan	248-765 €554,40

100-4 (BN2) - Carpet with black Armacord

Black	248-750 €554,40
Red	248-761 €554,40
Blue	248-771 €554,40
Honey Tan	248-766 €554,40



FOOTWELL LIGHT KIT

This LED kit allows fitting extra courtesy lamps in your car, ideal for illuminating the footwells. The simple kit can be connected to any 12V system and includes two LEDs, wiring harness and instructions.

Footwell light kit.....	903-651	€64,80
-------------------------	---------------	--------

100-6 (BN4/3000 BT7) side shift - Original

Black	248-781	€489,60
Red	248-797	NA
Blue	248-801	€489,60
Honey Tan	248-796	€489,60

100-6 (BN4/3000 BT7) side shift - Deluxe

Black	248-780	€552,00
Red	248-790	€552,00
Blue	248-800	€552,00
Honey Tan	248-795	€552,00

100-6 (BN4/3000 BN7) side shift - Original inc. spare tyre cover

Black	248-810	€579,60
Red	248-820	€579,60
Blue	248-830	€579,60
Honey Tan	248-825	€579,60

3000 (BN7) centre shift - Original

Black	248-840	€627,60
Red	248-850	€627,60
Blue	248-860	€627,60
Honey Tan	248-855	€627,60

3000 (BT7/BJ7) centre shift - Original

Black	248-780	€552,00
Red	248-790	€552,00
Blue	248-800	€552,00
Honey Tan	248-795	€552,00

3000 (BT7/BJ7) centre shift - Deluxe

Black	248-870	€579,60
Red	248-880	€579,60
Blue	248-890	€579,60
Honey Tan	248-885	€579,60

3000 (BJ8 to (c)26704) - Original

Black	248-871	€465,60
Red	248-881	€465,60
Blue	248-891	€465,60
Honey Tan	248-886	€465,60

3000 (BJ8 to (c)26704) - Deluxe

Black	248-870	€579,60
Red	248-880	€579,60
Blue	248-890	€579,60
Honey Tan	248-885	€579,60

3000 (BJ8 from (c)26705) - Original

Black	248-901	€465,60
Red	248-911	€465,60
Blue	248-921	€465,60
Honey Tan	248-916	€465,60

3000 (BJ8 from (c)26705) - Deluxe

Black	248-900	€595,20
Red	248-910	€595,20
Blue	248-920	€595,20
Honey Tan	248-915	€595,20

DOOR TOP RAILS



Just like the originals, our complete assembled rails include the sheet metal base with a moulded foam-core covered in durable black vinyl with a grain that matches our interior kits.

Door top rails, pair	858-158	€118,68
----------------------------	---------------	---------

FELT/RUBBER DOOR SEALS



Originally fitted to early cars, this felt/rubber material door seal is a more luxurious option for later cars. It features a steel wire core that clamps securely, and a correctly sized bulb to ease installation and improve sealing. Sold per meter.

Door seal.....	724031M.....	€10,20
----------------	--------------	--------

BOOKS, MANUALS & DVDS



Essential Buyer's guide - Big Healeys

The Essential Austin-Healey is an indispensable resource for anyone contemplating the purchase of an example of these iconic cars. A candid assessment of each model guides you to selecting the right model for your intended use, and arms you with the essential knowledge to select the right example of this increasingly popular marque.

Essential buyers guideMGL0401 .. €22,68



Factory Original Austin-Healey 100-6 & 3000

Marque expert Bill Piggott gives full details of correct specification and equipment, backed up by in-depth colour photography of outstanding examples of all models and variants. Body panels, external trim and badging, paint colours, interior trim, dashboard, instruments and controls, under-bonnet components, engine and transmission, lamps, and other features right down to the tool kit, are all covered.

Original series, 100-6, 3000MGL0246 .. €69,12



Factory Workshop Manual Reprints

Everything from basic tuning data, to torque settings and complete component rebuilding are covered by these comprehensive manuals.

100-4021-379 €58,44
100-6, 3000.....AKD1179 .. €67,80



Owner's Manuals Reprints

Reprints of the owner's manuals originally supplied with your car. From basic tuning and maintenance, to putting up the top.

100-497H996E ... €30,60
100-697H996H .. €30,60
BJ8 MkI-II212-670 €30,60
BJ8 MkIII.....AKD4094B. €30,60



Works Healey's in Details

Written by Graham Robson, this books tells the story of Donald Healey's introduction of the cars and his make into the world of rallying and racing, from the early Healey Elliott of the late 40's through to the Austin-Healey Sprite in 1967. Detailing the competition versions of the 'big Healey's' with legends such as Pat Moss, Timo Mainen and Paddy Hopkirk behind the wheel. Robson describes the career of each works car individually including drivers, entries and results, with countless illustrations and colour photography of surviving examples. For some, a trip down memory lane, and for others, an eye opening book into the world of competition Healey's.

Works Healey's in detail..... MGL0348 ...€82,68

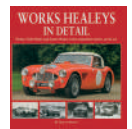

Austin-Healey 3000 Ultimate Portfolio

An excellent collection of contemporary reports featuring road tests, driving impressions, rallying, touring and much, much more. Austin-Healey 3000 owners will find this both an interesting read and an excellent addition to their bookcase.

Ultimate portfolio, 3000213-241 €40,80

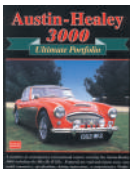

Austin-Healey 100 in Detail

The definitive reference work on the four-cylinder Austin-Healey 100, complete with in-depth technical descriptions, competition history, specially commissioned colour photography, rare archive pictures and advice on running these fantastic cars today.

Austin-Healey 100 in detail..... 213-242 ... €111,12



The cars of BMC

Along with a detailed history of the company and its creation, Robson provides a comprehensive directory of the marques and models that made up the BMC. From Austin to Wolseley, and taking in names such as Metropolitan and Vanden Plas along the way, each has a dedicated, detailed chapter.

The Cars of BMCMGL6615 .. €50,88

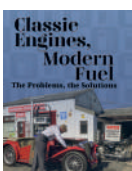

Classic Engines, Modern Fuels

Describes, in plain English, the findings of a research programme into modern petrol/gasoline and its effects on classic engines. The book includes practical descriptions of how a spark-ignition engine works, and how it can be tuned to avoid common problems.

Classic engines, modern fuelsMGL0085 .. €23,64

Classic Car Body Work

A book written for the home restorer who, until now, lacked the confidence to tackle bodywork. With specially devised techniques which don't rely on workshop plant, this book spans the gap between professional and amateur.

Classic car bodyworkMGL0330 .. €43,32

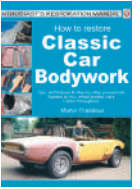

How to Paint a Classic Car

Taking you step-by-step through each stage of the painting process, from planning, preparation, and safety, to final painting and finishing, this book will give you the skills and the confidence you need for a perfect finish.

How to paint a classic carMGL0332 .. €34,68

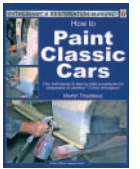

How to restore classic car interiors

Here is the ultimate resource packed with restoration know-how on all kinds of interior fittings in your classic car. This new volume produced in close cooperation with the editors of Europe's largest vintage car magazine OLDTIMER MARKET, provides easy-to-follow guidance on the repair and renovate carpets, headlinings, seats, wood and synthetic material parts, instruments, steering wheels: even how to succeed in making your radio sound just like new.

How to restore classic car interiors ...MGL0364 .. €43,32



Classic car suspension & steering wheels

A step-by-step illustrated guide to restoring and improving the suspension, steering and wheels of your classic car, this easy to follow manual is fully illustrated, and packed with useful tips and techniques.

Classic car suspension & steering wheels.MGL0394 .. €43,32

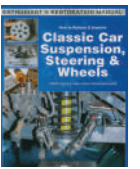

Lucas fault diagnosis manual

This Lucas guide presents a logical sequence of tests that may be carried out on starters, generators, regulators, ignition and lighting systems. Written for technicians, this book can be easily understood by the amateur mechanic/owner.

Lucas fault diagnosis manualGAC1029X...€8,64



Rule Britannia

Rule Britannia - When British Sports Cars Saved A Nation; With authoritative text from John Nikas and his team of dedicated researchers and contributors; historic imagery from archives maintained by marque clubs, manufacturers and museums; and modern portraits artfully captured in a studio setting by Michael Furman, the world's most renowned automotive photographer.

Rule BritanniaMGL0360 . €130,08



SU Carburettor needle chart

Needle chart gives the full range of needles and their dimensions to help guide you in your choice of needles.

SU needle chartALT9501... €18,36



SU workshop manual

Factory manual covering carburettors and fuel pumps.

SU workshop manual..... GAC1044X . €22,20

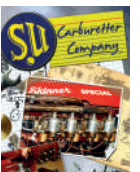

Tuning SU carburettors

This book looks into the basic design of the SU carb. It covers many areas including overhaul, tuning mixtures, jet and needle identifications. Hundreds of line illustrations of different types of SU carb models as used on many classic cars.

Tuning SU carburettors.....MGL0070 .. €23,64

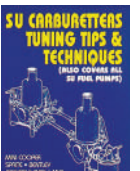

Weber carburettor tuning tips & techniques

This book is the distillation of many years' experience of working with Weber carbs. The mysteries of why and how they work and the practicalities of getting the best from them. Also setting-up, fault-finding, maintenance and repair are all covered.

Weber tuning tips & techniques213-431 €22,92

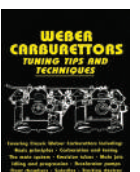

Tuning the A-series engine

This 3rd edition of the bible for all A-series engines was completed in 1999. The latest and greatest from David Vizard. This book has tremendous updates since the last edition!

Tuning the A-series engineMGL0063 .. €38,04

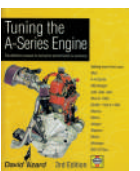



CUFFED BEANIE

Stay warm and look cool while showing appreciation for your favourite marque! Fashioned from 100% soft acrylic, the beanie has ribbed knit construction. It is cuffed and features a woven marque logo on the front and a Moss block label clipped to the left side of the back. Super comfortable and stretchable, this beanie will look great on you!

- Beanie, grey 217-766 €26,40
- Beanie, red 217-765 €26,40



KNIT SCARF

Brave the elements while showing appreciation for your favourite classic British car with this knit scarf. Made from an 80% cotton blend, its sturdy knit construction offers a feel as soft as a sweater. They are machine washable and made in the USA. Length: 80". Width: 8 1/2"

- Knit scarf, red 231-341 €39,48



WORKSHOP APRON

Ideal for those messy jobs, like engine building. This apron has adjustable straps and three large pockets.

- Workshop apron with MG logo GAC9935X ... €30,24



EMBROIDERED PATCHES

- 1 Austin-Healey wings GAC9953X €8,52
- 2 British Leyland GAC9960X €8,52
- 3 Union flag 229-510 €4,56
- 4 BMC GAC9961X €8,52



UMBRELLA

Steer clear of rain, wind or the scorching sun with our umbrella especially created for British car enthusiasts!

Customized with your favourite Marque logo, these 8-panel nylon umbrella features a telescopic metal shaft for durability, and an automatic open function for easy one-handed operation.

The umbrella has a rubberized comfort grip, and comes with a matching sleeve and wrist-strap.

Keep it in your car and be prepared to have a great time outdoors, no matter the weather!

- Umbrella, red 214-742 €30,72



MARQUE CUP HOLDER

Grab attention with custom tyre cup holders for your favourite classic British car. Approximately 4" tall by 3" wide, the rubber tyre drink holder has a neoprene liner. This custom cup holder keeps your drinks cool and also makes for a great promotional/giveaway item especially when you're hosting a get-together for classic car enthusiasts.

- Tyre cup holder, Austin-Healey 217-271 €9,00



THERMAL MUG

Our stylish thermal mug will maintain your drinks temperature whether hot or cold. The desk mug features a wider design with handle, a non-slip base and a removable cap.

- Desk mug 230-927 €22,20



STAINLESS STEEL PINT CUP

This quality insulated cup keeps your drinks hot or cool. The designed cup features the Austin-Healey wings logo. Get your silver coloured pint mug today or better yet, order it for your friends and share some classic cheer! Please note: Does not include a lid.

- Pint cup 217-567 €18,12



WATERPROOF BLANKET

These waterproof blankets bring a touch of comfort to any roadside picnic. Neatly folded into a parcel, it can be easily stored and carried with its durable handle. They are manufactured from grey acrylic with a foam layer and waterproof PEVA backing. Size 51" x 70".

- Austin-Healey logo picnic blanket231-385€43,20
- Moss logo picnic blanket.....231-370€43,20



COOL BAGS

Keep your drinks and sandwiches cool when going for a picnic in the sun with our cool bags sporting the logo of your favourite car.

- Austin-Healey logo cool bag.....214-692€17,64



GEAR STICK BOTTLE STOPPERS

Classic style gear stick bottle stoppers. Constructed from left bar with aluminium look top bezel and finished with either vintage white paint or Red wood. Featuring a standard 5 Speed H pattern on top.

The tapered tubber seal ensures a tight fit for all wine bottles and is also wide enough to fit port bottles, too.

- Red wood bottle stopperMAMCSTOPRW.... €20,64
- Vintage white bottle stopper.....MAMCSTOPVW.... €20,64



PETROL CAN HIP FLASKS

A great gift for any car lover. Shaped like a jerry can, this 5oz (142ml) hip flask is constructed from stainless steel and has either a rustic finish adding to its 'garage appeal', or black matt finish.

- Hip flask, silverMAMCFLASK.....€17,40
- Hip flask, blackMAMCFLASKB€17,40



WINE GLASS SET

Enjoy your favourite drink from these glasses bearing the Austin-Healey logo. Perfect for show picnics and summer evening BBQs.

- Wine glasses, set of 4230-988..... NA



SUN CATCHER ORNAMENTS

These 3" round sun-catcher ornaments are sure to add a sparkle wherever you hang them. With a clear acrylic background to let the sun shine through, you can hang these on your window, or even on your Christmas tree for a holiday season finish. Featuring logo of your favourite classic and supplied with a suction cup and foiled hanging cord for display. This small item with a year round use makes a perfect add-on to any order.

- Sun-Catcher, Austin-Healey round... 214-724..... €3,60
- Sun-Catcher, Austin-Healey script... 214-725..... €4,92



LEATHER KEY FOBS

Made in England, with a stitched leather fob and high quality enamelled badge, featuring the various logos.

- Austin-Healey key fobGAC4041..... €6,48
- BMC Rosette key fob.....CRSP401..... €6,48
- Union Jack key fobGAC4042..... €6,48



INSERT BEFORE DRIVE KEY RING

This marque specific key ring comes with a tag showing off the Moss block and "Insert Before Drive" script on one side, and the Austin-Healey logo on the other.

- Austin-Healey logo..... 217-266..... €4,44
- Moss logo 217-256..... €4,44



PERSONAL HEATED FLEECE BLANKET

The comfy cruise 12 volt heated travel blanket is the ideal travel companion for all weather conditions. Offering both comfort and warmth, its 42" x 58" size is large enough for two people and is perfect for warming one bench seat or two bucket seats at a time. The blanket features an 8 foot long fused cord and automatic temperature control. Made of 100% high quality polyester fleece.

- Personal heated blanket 12 volt 002-842..... €55,56



AUSTIN-HEALEY FLAG

Designed for outdoor use, but will look great hanging up in the garage or a wall in the house, these flags, sporting your favourite marques logo will let anyone who sees it know you're serious about your classic. Measures 3' x 5'.

- Flag, Austin-Healey wings logo 214-712..... €38,04



KNEELING PAD

Made from Softek closed cell foam, this kneeling pad is suitable for use in both the home and on the roadside. A perfect size to keep in the boot, or tucked behind the seat. Save your knees from the discomfort of hard floors and sharp stones, whilst showing off your favourite marque logo.

- Kneeling pad, Austin-Healey wings logo red 214-702..... €22,32



CLASSIC FLYING HELMET & GOGGLES

Reproductions of the helmets and flying goggles worn by WWII pilots of the Royal Air Force. The pilot helmets are a premium grade brown leather, with a soft brown cotton lining. Featuring a forehead buckle and strap adjuster to ensure a close fit, opening ear flaps secured with a press stud fastening, and an under-chin strap, secured with a metal buckle.

The motoring helmets are a premium grade brown leather, with a soft brown cotton lining. Built-in peak to shade the sun and neck protector to stop the wind chills, with under-chin strap, secured with a metal buckle. The original RAF specification goggles are made with polycarbonate glass lens, grey/blue enamel frames, brown leather padding and elasticated headband.

- 1 Leather pilot helmet, small, brownALCFHL/S.....€153,72
- Leather pilot helmet, medium, brownALCFHL/M....€153,72
- Leather pilot helmet, large, brownALCFHL/L€153,72
- Leather pilot helmet, x-large, brown.....ALCFHL/XL...€153,72
- 2 Leather motoring helmet, small, brown....ALCFHLL/S...€157,92
- Leather motoring helmet, medium, brown..ALCFHLL/M..€157,92
- Leather motoring helmet, large, brown....ALCFHLL/L...€157,92
- Leather motoring helmet, x-large, brown...ALCFHLL/XL..€157,92
- 3 RAF vintage goggles MK8.....ALCGMK8.....€174,72



BAR STOOL

Ideal for when you're having a well-earned 'cuppa in the garage admiring your handy work. 14" easy clean vinyl seats with 30" high chrome plated legs.

- 231-810..... €122,52

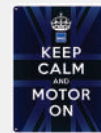

GARAGE SIGNS

Made from heavy 20 gauge steel, each 14" round sign boasts digitally printed Austin-Healey stack logo in detailed finish. Perfect for indoor or outdoor use, these sturdy metal signs look great wherever you put them. The holes drilled at top and bottom centre make them easy to mount.

- Austin-Healey round metal sign, 14" 214-731..... €22,92

High quality multi-coloured screen printed signs, perfect replicas of the originals.

- BMC dealer sign, 18" x 27"..... GAC9929X ..€115,56
- Keep calm and motor on sign, 12" x 16" 214-568..... €28,56
- Lucas sign, 12" x 16"..... 214-564..... €28,56
- Weber carburetors sign, 12" x 16"..... 214-562..... €28,56



230-390



230-355



230-388

Fitment: Cars must be negative earth. Units supplied without faceplate or knobs.

RETRO SOUND RADIOS

The RetroSound range of radio & MP3 players maintain the original 'twin knob' (DIN-D) style mounting required for many classic cars. Music can be played from external sources such as iPods, USB flash drives & SD cards, all connected out of sight.

San Diego

DAB/DAB+ Tuner (DAB antenna or DAB Antenna Adaptor required), AM/FM Tuner, iPod/iPhone & Android compatible, Bluetooth, x2 rear USB ports & x2 rear Auxiliary inputs. 32,000 colour LCD with built in amp (45 watts peak/25 watts RMS x 4 channels).

- RetroSound San Diego, chrome 230-383 €466,80
- RetroSound San Diego, black 230-388 €466,80

Hermosa

AM/FM Tuner, iPod/iPhone & Android compatible, x1 rear USB port & x2 rear Auxiliary inputs. Dual colour LCD display (white and green) with built in amp (45 watts peak/24 watts RMS x 4 channels).

- RetroSound Hermosa, chrome 230-390 €379,20
- RetroSound Hermosa, black 230-395 €379,20

Long Beach

AM/FM Tuner, iPod/iPhone & Android compatible, Bluetooth, x2 rear USB ports & x2 rear Auxiliary inputs. 32,000 colour LCD with built in amp (45 watts peak/25 watts RMS x 4 channels).

- RetroSound Long Beach, chrome 230-381 €504,00
- RetroSound Long Beach, black 230-386 €504,00

Laguna

Back to the basics with this AM/FM tuner with x1 rear auxiliary input. Adjustable-angle LCD display with built-in amp (40 watts peak/18 watts RMS x 4 channels).

- RetroSound Laguna, chrome 230-355 €248,40

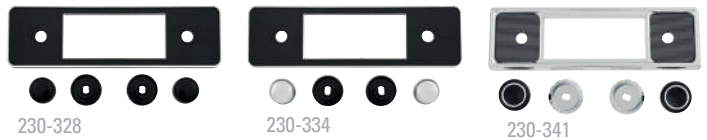

Faceplate and knob kits (F&K kits)

These kits let you finish off your RetroSound radio with the faceplate and knobs that match the original trim of your classic car. Knobs are available on their own as replacements. Please see our website for full range.

- F&K kit - chrome faceplate/chrome knobs 230-326 €61,08
- F&K kit - black faceplate/black knobs 230-327 €61,08
- F&K kit - black/black faceplate/chrome knobs 230-329 €61,08
- F&K kit - black/chrome faceplate/black knobs 230-328 €61,08
- F&K kit - black/chrome faceplate/chrome knobs 230-333 €61,08
- F&K kit - black/chrome faceplate/black/chrome knobs 230-334 €61,08
- F&K kit - Becker pinstripe 230-341 €59,52
- F&K kit - Blaupunkt black 230-342 €59,52
- F&K kit - Blaupunkt black/chrome 230-346 €61,08
- F&K kit - VW ivory 230-343 €59,52
- F&K kit - Ghia chrome 230-344 €59,52
- Knob set only - chrome 230-331 €26,28
- Knob set only - black 230-332 €26,40



230-505

230-545



230-530

230-550

RETROMOD SPEAKERS BY RETRO SOUND

The RetroMod range of speakers from RetroSound has been designed to compliment their range of Classic radios and have been manufactured to meet the demands of modern high performance amplifiers.

Dual voice coils (DVC) speakers

This system allows for 2 stereo channels (left & right) to be connected to the same single speaker. This means that originality can be maintained on cars where a single speaker was fitted in the centre of the dash or rear shelf. These speakers are supplied individually without mesh grilles, to fit existing mountings.

- 6.5" dia 3 way, DVC, no grilles (each) 230-505 €82,44
- 5" x 7" 3 way, DVC, no grilles (each) 230-545 €90,60
- 6" x 9" 3 way, DVC, no grilles (each) 230-510 NA

Single voice coils (SVC) speakers

The SVC range of speakers is a standard configuration single channel speaker for normal installations (left & right mounted speakers, such as doors or dash). These speakers are available in a range of sizes and specifications, see our website.

- 4.5" dia 2 way, 40W max, with grilles (pair) 230-535 €118,68
- 5" x 7" 3 way, 60W max, with grilles (pair) 230-540 €121,92
- 6" x 9" 3 way, 100W max, with grilles (pair) 230-530 NA
- 6" x 9" 3 way, 100W max, with grilles (pair) 230-531 NA
- Surface mount, 4" 2 way (pair) 230-565 €70,56
- Speaker pods, 4" x 6" (pair) 230-570 €189,00
- Speaker pods, 6.5" (pair) 230-575 €255,60

RetroMod 8" Subwoofer

The compact design and powerful bass response make this ideal for under seat mounting and numerous other in-car applications. The rigid die cast aluminium chassis and powerful Class D amplifier allows this sub to reproduce low frequencies down to 35Hz.

- 8" Subwoofer with internal amplifier 230-550 €273,60

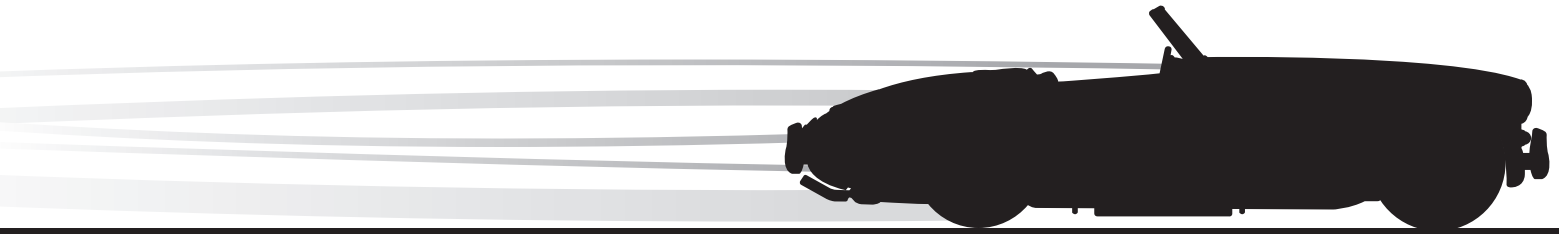

Austin-Healey Restoration Parts



General Specifications

	100-4 (BN1, BN2)	100-6 (BN4, BN6)	3000 (BN7, BT7)	3000 (BJ7/BJ8)
Vehicle Identification				
Vehicle Number Location	firewall	firewall	firewall	firewall
Engine Number Location	plate, LH side	plate, LH side	plate, LH side	plate, LH side
Gearbox Number Location	RH side by dipstick	RH side by dipstick	RH side by dipstick	RH side by dipstick
Rear Axle Number Location			LH rear of axle tube	LH rear of axle tube
Tune Up				
Engine Firing Order	1, 3, 4, 2	1, 5, 3, 6, 2, 4	1, 5, 3, 6, 2, 4	1, 5, 3, 6, 2, 4
Valve Rocker Clearance	0.012" cold	0.012" hot	0.012" hot	BJ7 0.012" hot, BJ8 0.012" cold
Idle Speed			500 RPM	500 RPM
Static Ignition Timing	6 deg. BTDC	6 deg. BTDC	5 deg. BTDC (12 deg MK2)	10 deg. BTDC
Dynamic Ignition Timing			15 deg. @ 600 RPM	15 deg. @ 600 RPM
Timing Mark Location	timing cover	timing cover	timing cover	timing cover
Distributor Make/Type	Lucas DM2	Lucas DM6	Lucas DM6A	Lucas 25D6
Contact Breaker (points) Gap	0.014"-0.016"	0.014"-0.016"	0.014"-0.016"	0.014"-0.016"
Rotation of Rotor	clockwise	counter clockwise	counter clockwise	counter clockwise
Ground Polarity	Positive	Positive	Positive	Positive
Ignition Coil Make/Type	Lucas B12	Lucas 12 volt	Lucas 12 volt	Lucas 12 volt
Spark Plug Make/Type	NA 8	Champion UN12Y	Champion UN12Y	Champion UN12Y
Spark Plug Gap	0.025"	0.024"	0.025"	0.025"
Carburettor Make/Type	SU H4	SU H4 (early) HD6 late	2xHD6 (MK1) 3xHS4 (MK2)	2xHS6 (BJ7)
Carburettor Main Jet	0.090 (except 100M)	0.090 (H4) 0.100 HD6	0.100 (MK1) 0.090 (Tri carb)	0.100 (BJ7) 0.125 (BJ8)
Carburettor Main Jet Needle	QH (except 100M)	AJ (H4) CV (HD6)	CV (MK1) DJ (MK2 tri carb)	BC (BJ7) UH (BJ8)
Carburettor Piston Spring	Yellow (except 100M)	Red (H4) Yellow (HD6)	Green (HD6), Red (HS4)	Green (BJ7) Red/Green (BJ8)
Vehicle & Engine				
Length	12' 7"	13' 1 1/2"	13' 1 1/2"	13' 1 1/2"
Width	5' 1/2"	5" 1/2"	5" 1/2"	5" 1/2"
Height	4' 1 1/4"	4' 1"	4' 1"	4' 1"
Ground Clearance	5 1/2"	5 1/2"	4 5/8"	4 5/8"
Track Front	4' 1"	4' 3/4"	4' 3/4"	4' 3/4"
Track Rear	4' 2 3/4"	4' 2"	4' 2"	4' 2"
Wheelbase	7' 6"	7' 8"	7' 8"	7' 8"
Turning Circle		35'	35' 7"	35' 7"
Toe-In	1/16"-1/8"	1/16"-1/8"	1/16"-1/8"	1/16"-1/8"
Unladen Weight	2176 lb.		2380 lb.	2490 lb.
Curb Weight		2436 lb.		2550 lb.
Original Tyre Size	5.90-15	5.90-15	5.90-15	5.90-15
Original Tyre Pressure Front (Cold)	20	20	20	20
Original Tyre Pressure Rear (Cold)	23	23	25	25
Replacement Tyre Size	165-70-15	165-70-15	165-70-15	165-70-15
Engine Type	ohv	ohv	ohv	ohv
Engine Displacement	2660cc	2639cc	2912cc	2912cc
Firing Order	1, 3, 4, 2	1, 5, 3, 6, 2, 4	1, 5, 3, 6, 2, 4	1, 5, 3, 6, 2, 4
Compression Ratio	7.5:1	8.25:1	9.0:1	9.0:1
Engine Bore	3.4375	3.125	3.281	3.281
Engine Stroke	4.375	3.5	3.5	3.5
Number of Cylinders	4	6	6	6
Oil Pressure Idle		25-30	20	20
Oil Pressure Normal	50-55	55-60	50	50
Electrical System	12 volt positive ground	12 volt positive ground	12 volt positive ground	12 volt positive ground
Fuel Pump Make/Type	SU electric HP	SU electric HP	SU type LCS	SU type LCS
Fuel Tank Capacity	14.4 gallons	14.4 gallons	14.4 gallons	14.4 gallons
Cooling System Capacity	24 pints	24 pints	22.8	22.8
Sump Capacity	14.11 pints	14.4 pints	15.3 pints	15.3 pints
Gearbox Capacity, non-overdrive		4.8 pints	6.9 pints	6.9 pints
Gearbox Capacity, overdrive	6.3 pints	6.3 pints	8.65 pints j6	8.65 pints
Rear Axle Capacity	3.6 pints	3.6 pints	3.6 pints	3.6 pints
Crankshaft				
Main journals	2.479-2.4795"	2.3742-2.3747"	2.3742-2.3747"	2.3742-2.3747"
Rod journals	2.0000-2.0005"	2.0000-2.0005"	2.0000-2.0005"	2.0000-2.0005"
Torque Settings (foot-pounds)				
Cylinder head studs		(33)*	(33)*	(33)*
Cylinder head nutse)	65-70	75	75	75
Main bearing nuts		75	75	75
Con rod set screws		50	50	50
Front cover screws		12	12	12
Back plate screws		50	50	50
Flywheel bolts	35-40	50	50	50
Rocker shaft bracket nuts		25	25	25

* All cylinder head studs should be put in the block only finger tight to avoid cracking the block.

Identification Numbers

When ordering parts, it is essential that your car is identified exactly, by model year and serial number. Since many part changes were made during model years, the car number, engine number and body number provide the only positive identification. Quite often a car's title will not show the correct model year. Before ordering parts, please use the space provided below to copy the applicable numbers from your car. Use of these numbers is the best way to insure that you order and receive the correct parts. Wherever possible, we have listed part applications by car number(c). In some cases, we had to use the engine numbers(e) or body numbers(b).

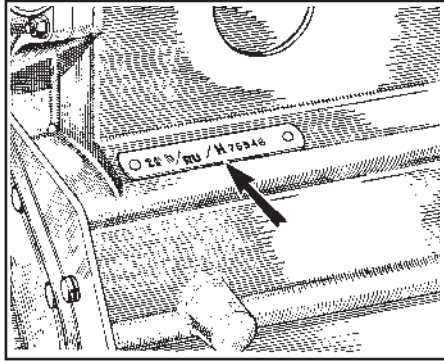

The Engine Number is stamped on a plate secured to the front left-hand side of the cylinder block. (100-6 and 3000 only.) The 100-4 is numbered on the right-hand side of the block.

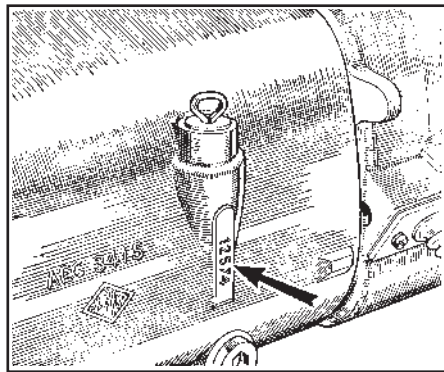

The Gearbox Number is stamped on the right-hand side of the gearbox below the oil level dipstick (except BN1).

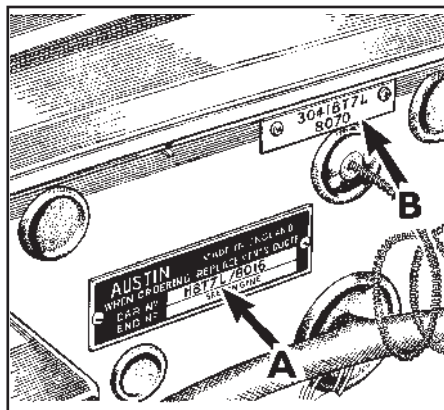

The Car Number (A) and the Body Number (B) are stamped on plates on the right-hand side of the firewall.

Year	Model	Starting Numbers:		Finishing Numbers:		Remarks
		Car:	Engine:	Car:	Engine:	
1953-'55	100 BN1	133234	136894	228026	(unknown)	3-speed
1955-'56	100 BN2	228047	(BN2 uses car/engine numbers)		233455	4-speed
1956-'59	100-6 BN4	22598	(BN4 uses car/engine numbers)		(unknown)	4 seater
1958-'59	100-6 BN6	501	60949	4650	26D-H77766	2 seater 6-port cylinder head
1959-'61	3000 BN7 Mkl	101	29D-H-101	13750	29D-H-26212	2-seater horizontal grille slats
1959-'61	3000 BT7 Mkl	101	29D-H-101	13750	29D-H-26212	4-seater horizontal grille slats
1961-'62	3000 BN7 MkII	13751	29E-H-101	18888	29E-H-5799	2-seater vertical grille slats 3 x 1 1/2" carburetors
1961-'62	3000 BT7 MkII	13751	29E-H-101	19853	29E-E5799	4-seater vertical grille slats 3 x 1 1/2" carburetors
1962-'63	3000 BJ7	17551	29F-101 29FF-101	25314	29F-6188	roll-up windows 2 x 1 3/4" carburetors
1963-'68	3000 BJ8	25315	29F-101 29KF-101 29KFA-224	43026	29FF-164	roll-up windows 2 x 2" carburetors wood veneered dash

Record Your Identification

Numbers Here:

Customer Number

Model & Year

Car Number

Body Number

Engine Number

Note: These pages list only the major items in each area, such as body work, electrical and brake components.

In many cases minor fittings, clamps and linkages etc... are not shown. In most circumstances Moss can supply both an OE (Original Equipment) part or an aftermarket part. The aftermarket part offers a high quality part but usually at a reduced price and in certain circumstances replaces the OE part when no longer available.

The aftermarket part is indicated by a letter "Z" at the end of the part number.

A

Accelerator Pedal & Shaft (BJ7-BJ8) Page 47
Accelerator Pedal & Shaft (BN1-BN2) Page 40-41
Accelerator Pedal & Shaft (BN4-BN7/BT7 - twin carb) Page 43
Accelerator Pedal & Shaft (BN7-BT7 - tri carb) Page 45
Air Filter, H Type (BN1-early BN4) Page 27
Air Filter, HD6 (late BN4-BN7-BT7) Page 29
Air Filter, HD8 (BJ8) Page 35
Air Filter, HS4 (BN7-BT7) Page 31
Air Filter, HS6 (BJ7) Page 33
Anti Roll Bar (Front) Page 66
Armrest (BJ8) Page 107

B

Back Plate (100-4) Page 7
Back Plate (100-6, 3000) Page 13
Battery & Fittings Page 90
Battery Cables Page 90
Bearing Set (100-4) Page 8-9
Bearing Set (100-6) Page 15
Body Panels (Inner) (100-4) Page 113
Body Panels (Inner) (100-6, 3000) Page 123
Body Panels (Outer) (100-4) Page 111
Body Panels (Outer) (100-6, 3000) Page 121
Bonnet (100-4) Page 111
Bonnet (100-6, 3000) Page 121
Bonnet Fittings (100-4) Page 117
Bonnet Fittings (100-6, 3000) Page 131
Brake Caliper (BN7-BJ8) Page 83
Brake Disc (BN7-BJ8) Page 83
Brake Drum (BN1-BN6) Page 82
Brake Drum Adjusters Page 84
Brake Hoses Page 86
Brake Light Switch Page 87
Brake Master Cylinder Page 80
Brake Pads Page 80
Brake Pedal Page 80
Brake Pipe Connectors Page 87
Brake Pipes Page 88
Brake Servo Page 81
Brake Servo Repair Kit Page 81
Brake Shoes Page 84
Bumpers (100-4) Page 114
Bumpers (100-6, 3000) Page 125

C

Camshaft (100-4) Page 8
Camshaft (100-4) Page 8
Camshaft (100-6, 3000) Page 15
Camshaft (100-6, 3000) Page 15
Carburettors, H Type (BN1-early BN4) Page 27
Carburettors, HD6 (late BN4-BN7/BT7) Page 29
Carburettors, HD8 (BJ8) Page 35

Carburettors, HS4 (BN7-BT7) Page 31
Carburettors, HS6 (BJ7) Page 33
Carpet Sets (BJ8) Page 145
Carpet Sets (BN1-BJ7) Page 144
Chassis Page 108
Choke Cable (BJ7-BJ8) Page 47
Choke Cable (BN1-BN2) Page 40
Choke Cable (BN4-BN7-BT7 - twin carb) Page 43
Choke Cable (BN7-BT7 - tri carb) Page 45
Cigarette Lighter (BJ8) Page 107
Cigarette Lighter (BN1-BJ7) Page 105
Clutch Fork (100-4) Page 49
Clutch Fork (100-6, 3000) Page 51
Clutch Master Cylinder (100-6, 3000) Page 51
Clutch Pedal (100-4) Page 49
Clutch Pedal (100-6, 3000) Page 51
Clutch Pipes (1006, 3000) Page 51
Clutch Plate (100-4) Page 49
Clutch Plate (100-6, 3000) Page 51
Clutch Push Rod (100-6, 3000) Page 51
Clutch Release Bearing (100-4) Page 49
Clutch Release Bearing (100-6, 3000) Page 51
Clutch Shaft (100-4) Page 49
Clutch Shaft (100-6, 3000) Page 51
Clutch Slave Cylinder (100-6, 3000) Page 51
Coil Spring (Front) Page 66
Con Rod Bearing Sets (100-4) Page 9
Con Rod Bearing Sets (100-6, 3000) Page 15
Con Rods (100-4) Page 9
Con Rods (100-6, 3000) Page 15
Condenser (100-4) Page 91
Condenser (100-6, 3000) Page 92
Contact Sets (Points) (100-4) Page 91
Contact Sets (Points) (100-6, 3000) Page 92
Control Arm Page 66
Control Box Page 96
Crankshaft (100-4) Page 8
Crankshaft (100-6, 3000) Page 15
Cylinder Head (100-4) Page 7
Cylinder Head (100-6 - 2 port) Page 16
Cylinder Head (100-6) Page 13
Cylinder Head (100-6, 3000 - 6 port) Page 17
Cylinder Head Studs (100-4) Page 7
Cylinder Head Studs (100-6 - 2 port) Page 16
Cylinder Head Studs (100-6, 3000 - 6 port) Page 17
Cylinder Head Studs (100-6, 3000) Page 13

D

Dashboard (BJ8) Page 107
Dashboard (BN1-BJ7) Page 105
Differential (early BN1) Page 73
Differential (late BN1-BJ8) Page 73
Distributor (100-4) Page 91
Distributor (100-6, 3000) Page 92
Distributor Cap (100-4) Page 91
Distributor Cap (100-6, 3000) Page 92
Door Seal Page 141
Doors & Fittings (BJ7-BJ8) Page 129
Doors & Fittings (BN1-BN2) Page 114
Doors & Fittings (BN4-BT7) Page 127
Dynamo Page 89
Dynamo Adjusting Link Page 89
Dynamo Mounts Page 89
Dynamo Pulley & Fan Page 89

E

Electrical Switches Page 96

Engine Bay Fittings (100-4) Page 117
Engine Bay Fittings (100-6, 3000) Page 131
Engine Gasket Sets (100-4) Page 7
Engine Gasket Sets (100-6 - 2 port) Page 16
Engine Gasket Sets (100-6, 3000 - 6 port) Page 17
Engine Gasket Sets (100-6, 3000) Page 13
Engine Mountings (100-4) Page 7
Engine Mountings (100-6, 3000) Page 13
Exhaust Manifold (100-4) Page 11
Exhaust Manifold (100-6 - 2 port) Page 18
Exhaust Manifold (100-6, 3000 - 6 port) Page 19
Exhaust Manifold (3000, triple carb) Page 20
Exhaust Manifold Gasket (100-6 - 2 port) Page 18
Exhaust Mountings (BJ8) Page 25
Exhaust Mountings (BN1-BJ7) Page 24
Exhaust Systems (BJ8) Page 25
Exhaust Systems (BN1-BJ7) Page 24
Exhaust Valves (100-4) Page 10
Exhaust Valves (100-6 - 2 port) Page 16
Exhaust Valves (100-6, 3000 - 6 port) Page 17

F

Fan Belt (100-4) Page 22
Fan Belt (100-6, 3000) Page 23
Fan Blade (100-6, 3000) Page 23
Flasher Unit Page 96
Flywheel (100-4) Page 8
Flywheel (100-6, 3000) Page 15
Front & Rear Lamps (BN1-BN2) Page 101
Front & Rear Lamps (BN4-BJ8) Page 102
Front Body Fittings (100-4) Page 117
Front Body Fittings (100-6, 3000) Page 131
Front Plate (100-4) Page 7
Front Plate (100-6, 3000) Page 13
Front Wing (100-4) Page 111
Front Wing (100-6, 3000) Page 121
Fuel Cap (BN1-early BJ8) Page 36
Fuel Cap (late BJ8) Page 37
Fuel Filter Page 36
Fuel Pipes & Fittings Page 39
Fuel Pump Page 39
Fuel Tank Page 39
Fuel Tank Filler Hose (BN4-BJ8) Page 39
Fuel Tank Fitting Kit Page 36
Fuel Tank Sender Unit Page 39
Fuse Box & Fuses (100-4) Page 91
Fuse Box & Fuses (100-6, 3000) Page 92

G

Gauges (BJ8) Page 107
Gauges (BN1-BJ7) Page 105
Gearbox (BN1 - 3 speed) Page 53
Gearbox (Centre Gear Change) Page 57
Gearbox (Internal) (4 speed) Page 59
Gearbox (Offset Gear Change) Page 55
Gearbox Cover Page 141
Gearbox Mountings Page 64
Glove Box (BJ8) Page 107
Grille Fittings (100-4) Page 117
Grille Fittings (100-6, 3000) Page 131

H

Handbrake Cable Page 85
Hardtop Page 134
Headlamp Rims Page 100
Headlamps Page 100
Heater Hoses Page 99
Heater Motor Page 99
Hood Fittings (BJ7-BJ8) Page 138

Hood Fittings (BN1-BN2) Page 135
Hood Fittings (BN4-BT7) Page 137
Hood Frame Page 147
Hoods Page 146
Horn Push Page 68
Horn Units Page 96
Hub (Front) Page 66
Hub (Rear) (early BN1) Page 73
Hub (Rear) (late BN1-BJ8) Page 75
Hub Caps (BN4-BJ8) Page 78

I

Ignition Coil (100-4) Page 91
Ignition Coil (100-6, 3000) Page 92
Ignition Leads (100-4) Page 91
Ignition Leads (100-6, 3000) Page 92
Ignition Switch Page 96
Inlet Manifold (100-6, 3000 - 6 port, twin carb) Page 19
Inlet Manifold (3000, tri carb) Page 20
Inlet Valves (100-4) Page 10
Inlet Valves (100-6 - 2 port) Page 16
Inlet Valves (100-6, 3000 - 6 port) Page 17
Instruments (BJ8) Page 107
Instruments (BN1 to BJ7) Page 105
Interior Mirror Page 124
Interior Trim Fittings Page 141

J

Jack Page 79

K

King Pin Kit Page 66

L

Leaf Spring (Rear) (BN1-early BJ8) Page 76
Leaf Spring (Rear) (late BJ8) Page 77

M

Manifolds (100-4) Page 11
Manifolds (100-6 - 2 port) Page 18
Manifolds (100-6, 3000 - 6 port) Page 19
Manifolds (3000 - tri carb) Page 20

N

Needles, H Type (BN1-early BN4) Page 27
Needles, HD6 (late BN4-BN7/BT7) Page 29
Needles, HD8 (BJ8) Page 35
Needles, HS4 (BN7-BT7) Page 31
Needles, HS6 (BJ7) Page 33
Number Plate Lamps (BN1-BN2) Page 101
Number Plate Lamps (BN4-BJ8) Page 103

O

Oil Cooler (Engine) (100-4) Page 22
Oil Cooler (Engine) (100-6, 3000) Page 23
Oil Filler Cap (100-4) Page 10
Oil Filler Cap (100-6 - 2 port) Page 16
Oil Filler Cap (100-6, 3000 - 6 port) Page 17
Oil Filter (100-4) Page 9
Oil Filter (100-6, 3000) Page 21
Oil Filter Adaptor (100-4) Page 9
Oil Filter Adaptor (100-6, 3000) Page 21
Oil Pump (100-4) Page 9
Oil Pump (100-6, 3000) Page 15
Overdrive (BN1) Page 61
Overdrive (BN2-BJ8) Page 63
Overdrive Solenoid (BN1) Page 61
Overdrive Solenoid (BN2-BJ8) Page 63
Overdrive Switch Page 64

P

Pedal Box (100-6, 3000)	Page 51
Piston & Rings (100-4)	Page 8
Piston & Rings (100-6, 3000)	Page 15
Propshaft (BN1-early BJ8)	Page 76
Propshaft (late BJ8)	Page 77
Push Rod (100-4)	Page 9-10
Push Rod (100-6 - 2 port)	Page 16
Push Rod (100-6, 3000 - 2 port)	Page 17
Push Rod (100-6, 3000)	Page 15

R

Radiator (100-4)	Page 22
Radiator (100-6, 3000)	Page 23
Radiator Hoses (100-4)	Page 22
Radiator Hoses (100-6, 3000)	Page 23
Radio Console (BJ8)	Page 107
Rear Body Fittings (100-4)	Page 119
Rear Body Fittings (100-6, 3000)	Page 133
Rear Spring & Fittings (BN1-early BJ8)	Page 76
Rear Spring & Fittings (late BJ8)	Page 77
Rear Wing (100-4)	Page 111
Rear Wing (100-6, 3000)	Page 121
Reflector (BN1-BN2)	Page 101
Reflector (BN4-BJ8)	Page 101
Relief Valve (100-4)	Page 9
Relief Valve (100-6, 3000)	Page 15
Rev Counter (BJ8)	Page 107
Rev Counter (BN1-BJ7)	Page 105
Rocker Cover (100-4)	Page 10
Rocker Cover (100-6 - 2 port)	Page 16
Rocker Cover (100-6, 3000 - 6 port)	Page 17
Rocker Shaft (100-4)	Page 10
Rocker Shaft (100-6 - 2 port)	Page 16
Rocker Shaft (100-6, 3000 - 6 port)	Page 17
Rotor Arm (100-4)	Page 91
Rotor Arm (100-6, 3000)	Page 92

S

Seat Cover Kits (BJ8)	Page 145
Seat Cover Kits (BN1-BJ7)	Page 144
Seat Foams	Page 143
Seat Frames	Page 143
Seat Runners	Page 143
Selector Shaft (BN1 - 3 speed)	Page 53
Selector Shaft (Centre Gear Change)	Page 57
Selector Shaft (Offset Gear Change)	Page 55
Shock Absorber (Front)	Page 66
Shock Absorber (Rear) (BN1-early BJ8)	Page 76
Shock Absorber (Rear) (late BJ8)	Page 77
Side Screen (BJ7-BJ8)	Page 138
Side Screen (BN1-BN2)	Page 135
Side Screen (BN4-BT7)	Page 137
Side Screen Sets	Page 148
Spark Plug (100-4)	Page 91
Spark Plug (100-6, 3000)	Page 92
Speedometer (BJ8)	Page 107
Speedometer (BN1-BJ7)	Page 105
Speedometer Cable (BJ8)	Page 107
Speedometer Cable (BN1-BJ7)	Page 105
Spigot Bush (100-4)	Page 8
Spigot Bush (100-6, 3000)	Page 15
Starter Motor	Page 90
Starter Relay	Page 90
Steering Arm	Page 66
Steering Box (BN1-early BN2)	Page 69
Steering Box (late BN2-early BN4)	Page 70
Steering Box (late BN4/BN6-BJ8)	Page 71
Steering Columns (BN1-early BN2)	Page 69
Steering Columns (late BN2-early BN4)	Page 70
Steering Columns	

(late BN4/BN6-BJ8)	Page 71
Steering Wheels	Page 68
Stub Axle	Page 66
Sump (100-4)	Page 7
Sump (100-6, 3000)	Page 13

T

Tachometer (BJ8)	Page 107
Tachometer (BN1-BJ7)	Page 105
Thermostat (100-6 - 2 port)	Page 16
Thermostat (100-6, 3000 - 6 port)	Page 17
Thermostat (Cooling) (100-4)	Page 22
Thermostat (Cooling) (100-6, 3000)	Page 23
Timing Chain (100-4)	Page 8
Timing Chain (100-6, 3000)	Page 15
Timing Shaft (100-4)	Page 8
Timing Shaft (100-6, 3000)	Page 15
Tonneau Cover	Page 139
Tonneau Rails & Fittings	Page 139
Tools	Page 79
Top Trunnion	Page 66
Track Rod End	Page 72
Trim Panel Kits (BJ8)	Page 145
Trim Panel Kits (BN1-BJ7)	Page 144

U

U bolts (Rear Springs) (BN1-early BJ8)	Page 76
U bolts (Rear Springs) (late BJ8)	Page 77
Universal Joint (Propshaft) (BN1-early BJ8)	Page 76
Universal Joint (Propshaft) (late BJ8)	Page 77

V

Valve Guides (100-4)	Page 10
Valve Guides (100-6 - 2 port)	Page 16
Valve Guides (100-6, 3000 - 6 port)	Page 17
Valve Springs (100-4)	Page 10
Valve Springs (100-6 - 2 port)	Page 16
Valve Springs (100-6, 3000 - 6 port)	Page 17

W

Washer Bottle	Page 95
Water Pump (100-4)	Page 22
Water Pump (100-6, 3000)	Page 23
Wheel Bearing (Front)	Page 66
Wheel Bearing (Rear) (early BN1)	Page 73
Wheel Bearing (Rear) (late BN1-BJ8)	Page 75
Wheel Cylinder (Front) (BN1-BN6)	Page 82
Wheel Cylinder (Rear)	Page 84
Wheel Nuts	Page 78
Wheel Spinners	Page 78
Wheels	Page 78
Windscreen (100-4)	Page 124
Windscreen (100-6, 3000)	Page 124
Windscreen Washer Jets	Page 95
Wiper Arms	Page 94
Wiper Blades	Page 94
Wiper Motor	Page 94
Wiper Rack	Page 94
Wiring Colour Codes	Page 149
Wiring Harness	Page 97
Wishbone Arm	Page 66

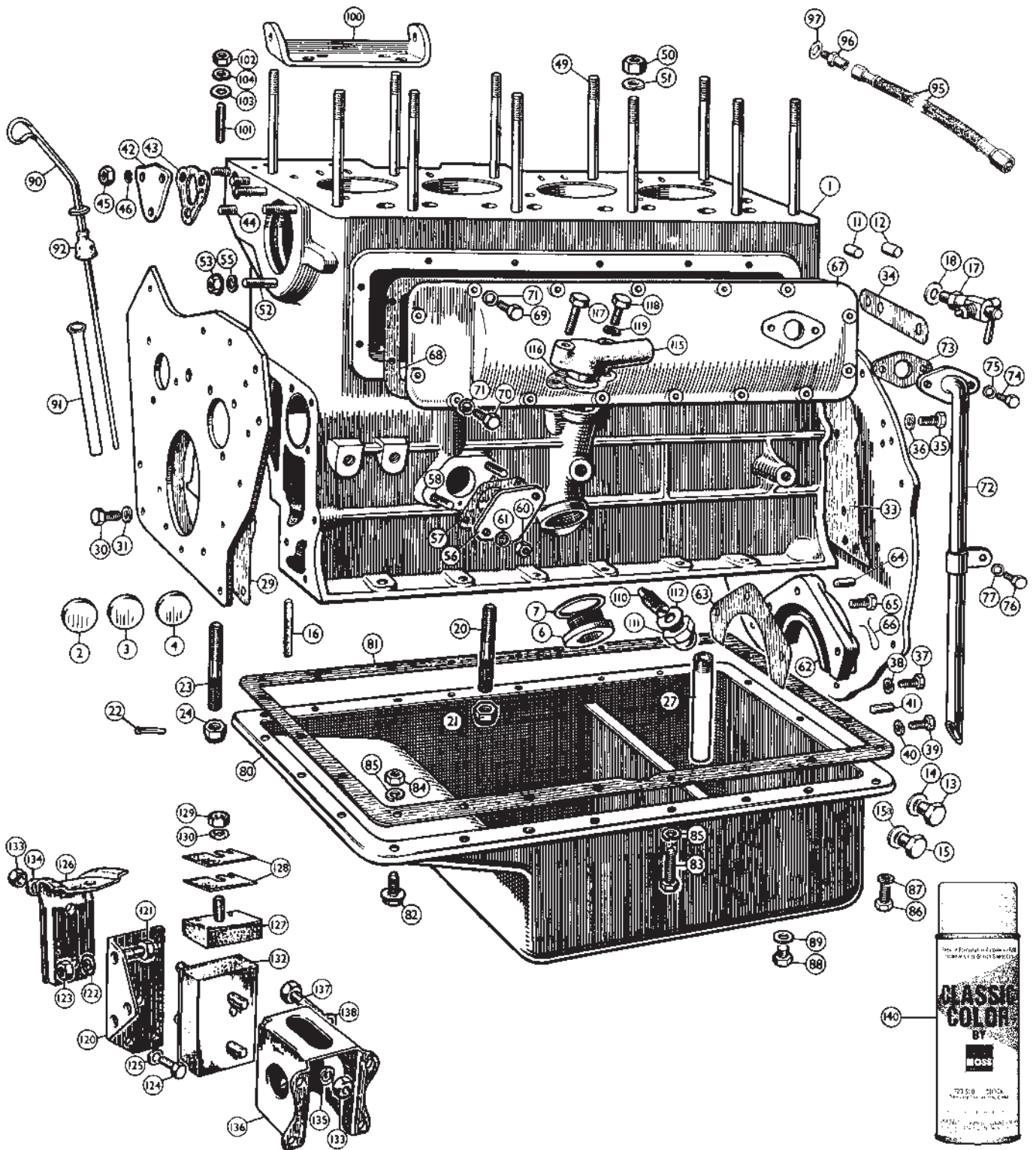

ill.	Part Number	Price €ea.	Description	Req.	Details
External Engine 100-4					
1			NA CYLINDER BLOCK	1	
	328-238	€17.16	CORE PLUG SET, cylinder block	1	(includes nos. 2, 3 & 4)
2	2K8169	€1.92	CORE PLUG, steel, cylinder block	5	1-5/8"
	328-231	€4.44	CORE PLUG, brass, cylinder block	5	1-5/8" (not in set)
3	328-015	NA	CORE PLUG, steel, water gallery, side	1	
4	2K8160	€2.16	CORE PLUG, steel, water gallery, rear	1	1-5/16"
		NA	RESTRICTOR, cam bearing oil feed	1	
6		NA	PLUG, distributor & oil pump spindle bores	2	
7	6K432	€5.16	WASHER, for plug	2	
		NA	PLUG, oil ways and water gallery	7	
	AEK122	€12.60	PLUG, main oil channel, front	1	
	6K433	€3.24	WASHER, copper	1	
11		NA	TAPERED PLUG, main oil channel, rear	1	
12		NA	TAPERED PLUG, block, top face	2	
13	328-080	NA	THREADED PLUG, rear bearing cap	1	
14	ARH1499	€1.20	SEALING WASHER, 1/16"	A/R	
15	53K2853	€11.52	PLUG, oil cooler boss	1	
15a	ARH1499	€1.20	WASHER for plug	1	
16		NA	PLUG, felt, front & rear main bearing caps	4	
17	835-600	NA	DRAIN TAP	1	
18	ARH1499	€1.20	SEALING WASHER, 1/16", fibre	A/R	
	2K4975	€0.96	SEALING WASHER, 1/2", fibre	A/R	
	324-640	NA	SEALING WASHER, 3/32"	A/R	
20	329-620	NA	STUD, main bearing cap	6	
21	309-005	€9.72	NUT	6	BN1 to C.E.207105
22		NA	SPLIT PIN, on nut	6	
23	329-630	€16.92	STUD, main bearing cap	6	
24	309-010	€3.36	NUT	6	BN1 from C.E.207106, BN2
		NA	WASHER, locking	6	
		NA	GASKET, rear main bearing cap	1	
27		NA	DRAIN PIPE, rear bearing cap	1	
29		NA	GASKET, front plate	1	
30	320-560	€3.72	BOLT, plate to block	5	
31	GHF333	€0.72	WASHER, locking	5	
33		NA	GASKET, back plate	1	
34		NA	GASKET, back plate, top	1	
35		NA	BOLT, rear plate to block	8	
36	GHF333	€0.72	WASHER, locking	8	
37		NA	BOLT, blanking unused holes	2	
38	GHF332	€0.84	WASHER, locking	2	
39		NA	BOLT, rear plate to bearing cap	2	BN1 from C.E.226095, BN2
40	GHF332	€0.84	WASHER, locking	2	
41	1G752	€2.40	DOWEL, rear engine plate	2	
42	1B1038	€43.68	BLANKING PLATE, front cover & water gallery	1	
43	697-310	NA	GASKET, front water gallery	1	
44		NA	STUD	3	
45	AJD8104	€1.08	NUT	3	
46	GHF331	€0.84	WASHER, locking	3	
49	328-785	€17.64	STUD, cylinder head	11	
50	2K6995	€4.56	NUT, cylinder head stud	11	
51	GHF303	€0.72	WASHER, plain	11	
52	329-635	NA	STUD, water pump to block	3	
53		NA	NUT, shouldered, manifold side	2	
	AJD8106Z	€0.96	NUT, plain	1	
55	GHF333	€0.72	WASHER, locking	3	
56		NA	BLANKING PLATE, fuel pump drive aperture	1	
57		NA	GASKET	1	
58		NA	STUD	2	
		NA	COLLAR, for stud	2	
60	AJD8105Z	€0.72	NUT	2	
61	GHF332	€0.84	WASHER, locking	2	
62	031-208	NA	OIL THROWER, block	1	
63	697-340	NA	GASKET, oil thrower	1	
64	325-350	NA	DOWEL	2	BN1 from C.E.226095, BN2
65		NA	BOLT	3	
66		NA	LOCKING WIRE	1	14" length
67	021-851	NA	SIDE COVER	1	
68	021-901	€7.08	GASKET	1	
69	320-950	NA	BOLT, long	14	
70	320-960	€2.40	BOLT, short	1	
71	324-225	€1.08	WASHER, fibre	15	
72	021-904	NA	VENT PIPE, with clip	1	
73		NA	GASKET, vent pipe	1	
74	320-960	€2.40	BOLT, flange to block	2	
75	GHF331	€0.84	WASHER, locating	2	
76	320-360	€1.92	BOLT, clip to block	1	
77	GHF332	€0.84	WASHER, locking	1	
80	62B104	NA	SUMP, steel	1	
81	AJM551	€10.32	GASKET, sump	1	
82	320-935	NA	BOLT, with washer, sump to block	20	
		NA	WASHER, plain, for bolt	20	
83	AJD6108Z	€2.64	BOLT, long, 5th from front LH side	1	attaches exhaust bracket
84	AJD8104	€1.08	NUT	1	
85	GHF331	€0.84	WASHER, locking	1	
86	AJD6155Z	€1.56	BOLT, centre, rear	1	
87		NA	WASHER, fibre	1	
88	2H4685	€10.32	PLUG, oil drain	1	
89	6K431B	€1.44	WASHER, copper	1	
90	830-270	NA	DIPSTICK	1	
91	1B1063	€16.44	TUBE, dipstick	1	
92	1B1735	€10.92	DUST CAP	1	
95	376-182	NA	OIL LINE, flexible	1	orig. type

ill.	Part Number	Price €ea.	Description	Req.	Details
	AHU1020	€19.80	OIL LINE, flexible	1	replacement
96	021-902	€19.56	UNION	1	
97	ARH1499	€1.20	WASHER	1	
100	021-903	€66.96	BRACKET, dynamo	1	
101		NA	STUD, bracket to block	4	
102		NA	NUT	4	
103	GHF301	€0.60	WASHER, plain	4	
104	GHF332	€0.84	WASHER, locking	4	
110	830-280	€21.72	LOCATING SCREW, oil pump	1	
111	310-850	€16.32	CAP NUT	1	
112	ARH1499	€1.20	WASHER, fibre	1	original
		NA	WASHER, copper	1	alternative
115		NA	COVER, tachometer drive gear	1	
116		NA	GASKET, tachometer drive gear	1	
117	320-400	€3.96	BOLT, long	1	
118	320-401	€3.24	BOLT, short	1	
119	GHF332	€0.84	WASHER, locking	2	
120		NA	BRACKET, engine support	2	
121		NA	BOLT, bracket to front engine plate	4	
122	GHF333	€0.72	WASHER, locking	4	
123	AJD8106Z	€0.96	NUT	4	
124		NA	BOLT, bracket to block	4	
125	GHF333	€0.72	WASHER, locking	4	
126		NA	BRACKET, engine mounting buffer	2	
127	1B4428	€9.48	BUFFER, engine mounting (SAE threads)	2	
128		NA	PACKING PIECE, .048	A/R	
		NA	PACKING PIECE, .036	A/R	
129	GHF201	€0.84	NUT	2	
130	GHF332	€0.84	WASHER, locking	2	
132	ACB9407	€16.32	ENGINE MOUNT (SAE threads)	2	
133	GHF203	€0.72	NUT	8	
134		NA	WASHER, locking	2	
135		NA	WASHER, locking	4	
136		NA	EXTENSION, engine mounting bracket	2	
137	GHF105	€0.84	BOLT, extension to chassis	8	
138	GHF333	€0.72	WASHER, locking	8	
NI	CB500	€92.64	GASKET SET, cylinder head 1		
NI	GEG271	€42.84	GASKET SET, bottom end 1		

Note: Gearbox mountings are listed on page 64.

Engine Paint

140	CCEP2	€23.04	ENGINE PAINT, metallic green.	A/R	12 oz. aerosol
-----	-------	--------	-------------------------------	-----	----------------

Note: Some very early BN1 engines were painted a medium/dark bluish grey. We do not have paint in this color.

220-576	NA	PRIMER, high temp for engine paint	A/R	
---------	----	------------------------------------	-----	--

Gaskets

CB500	€92.64	HEAD GASKET SET	1	
-------	--------	-----------------	---	--

Note: Includes gaskets for cylinder head, manifolds, valve cover, carb. mounting, water outlet elbow, exhaust flange, plus several misc. gaskets, washers, and small rubber seals.

GEG271	€42.84	CONVERSION GASKET SET	1	inc. all items listed below
16	NA	PLUG, felt, front & rear main bearing caps	4	
	NA	GASKET, rear main bearing cap	1	
29	NA	GASKET, front plate	1	
33	NA	GASKET, back plate	1	
34	NA	GASKET, back plate, top	1	
43	697-310	NA	GASKET, front water gallery	1
57	NA	GASKET, fuel pump blanking plate	1	
63	697-340	NA	GASKET, oil thrower	1
68	NA	GASKET, side cover	1	
73	NA	GASKET, vent pipe	1	
81	AJM551	€10.32	GASKET, sump	1
89	6K431B	€1.44	WASHER, copper, sump drain plug	1
116	NA	GASKET, tachometer drive gear	1	
	NA	GASKET, for filter head and block	2	
021-051	€6.72	OIL SEAL, timing cover, felt	1	
	NA	GASKET, timing cover	1	
697-330	€1.44	GASKET, water pump to block	1	

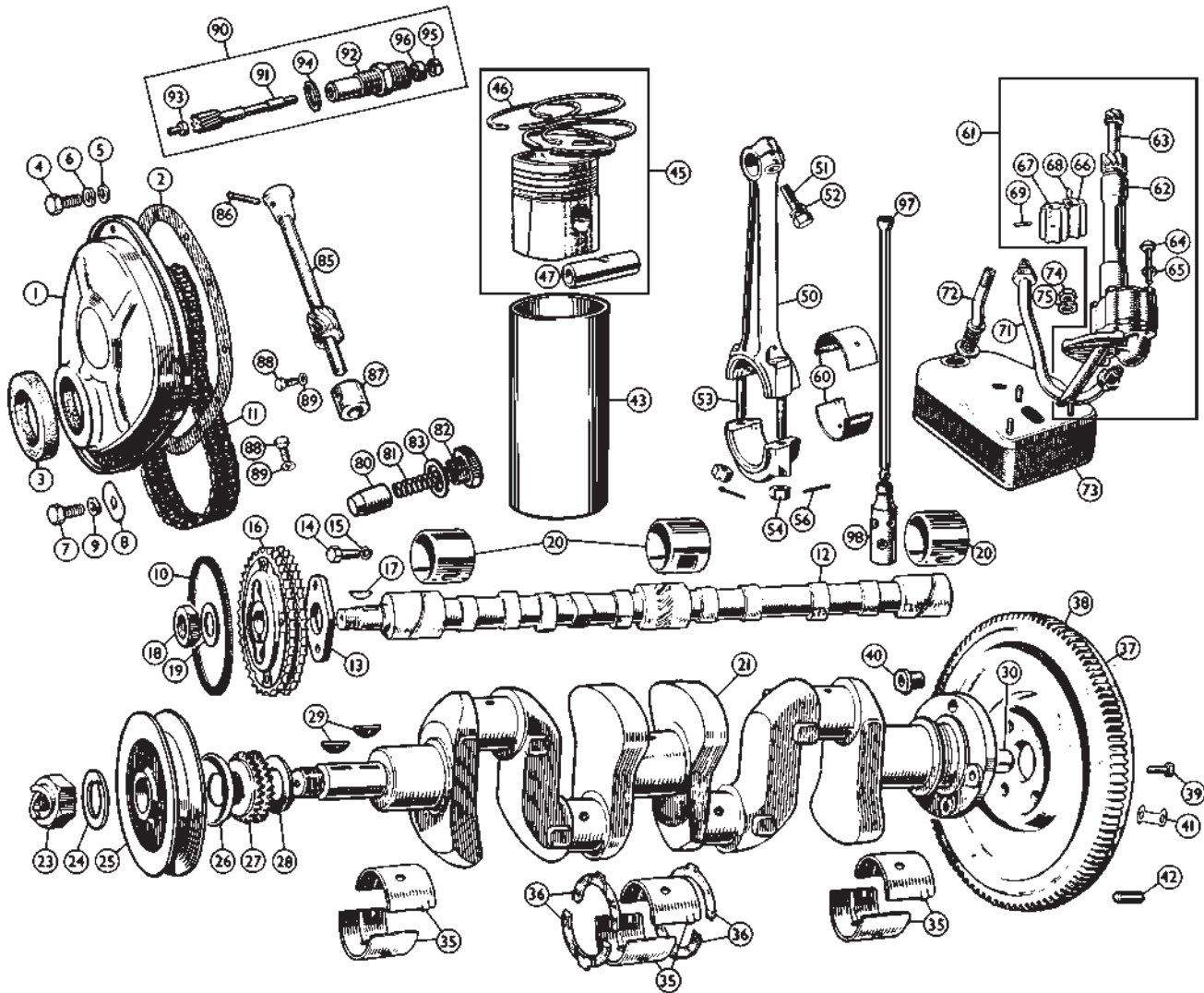

iii. Part Number Price €ea. Description Req. Details

Internal Engine 100-4

1	NA	TIMING COVER	1	
2	NA	GASKET, timing cover	1	
3	021-051	€6.72 OIL SEAL, timing cover, felt	1	
4	320-360	€1.92 BOLT, cover to crankcase	7	
5	2K7440	€2.16 WASHER, oval, 5/16"	7	
6	GHF332	€0.84 WASHER, locking	7	
7	NA	BOLT, cover to plate	5	
8	2K5197	€0.84 WASHER, oval, 1/4"	5	
9	GHF331	€0.84 WASHER, locking	5	
10	8G528	€5.04 TENSIONER RING, timing chain	1	
11	600-091	€63.12 TIMING CHAIN, heavy duty upgrade	1	
	2H4286	€16.44 TIMING CHAIN	1	
12	1B1573	NA CAMSHAFT, standard	1	
	021-420	€764.40 CAMSHAFT, Le Mans type	1	suitable for BN1 & BN2
13	031-210	€25.68 LOCATING PLATE	1	
14	320-370	€4.20 BOLT	2	
15	GHF332	€0.84 WASHER, locking	2	
16	NA	CAMSHAFT GEAR ASSY	1	
	838-020	€142.92 CAMSHAFT GEAR	1	

Note: Does not include oil catchers; includes rivets to re-use original sheet metal oil catchers.

17	WKN606	€3.48 KEY	1	
18	AEC247	€9.12 NUT	1	
19	1B1219	€3.24 TAB WASHER	1	
20	AEC3007STD	€57.12 CAM BEARING SET	1	
21	021-351	NA CRANKSHAFT, remanufactured	1	with bearings
		NA OIL RESTRICTOR	4	
23	031-204	€37.08 NUT, starting (crank dog nut)	1	
24	12B681	€6.84 LOCKWASHER	1	
25	837-590	€142.92 PULLEY, crankshaft	1	
26	837-070	€9.24 OIL THROWER	1	
27	AEC2026	€44.40 CRANKSHAFT GEAR	1	
28	145276	€2.04 SHIM	A/R	
29	WKN608	€2.40 KEY	2	
30	1K369	€5.16 SPIGOT BUSH	1	
35	021-035	€72.36 MAIN BEARING SET, std.	1	
	AEM3241010	€75.84 MAIN BEARING SET, .010	1	
	021-037	€73.68 MAIN BEARING SET, .020	1	

iii. Part Number Price €ea. Description Req. Details

	AEM3241030	€75.84 MAIN BEARING SET, .030	1	
	AEM3241040	€75.84 MAIN BEARING SET, .040	1	
36	AEW2015STD	€18.36 THRUST WASHER SET, std.	1	
	828-010	€20.16 THRUST WASHER SET, .005	1	
	828-015	NA THRUST WASHER SET, .010	1	
37	NA	FLYWHEEL ASSEMBLY	1	
38	1B1714	€53.40 RING GEAR	1	
39	320-980	€9.24 BOLT, flywheel to crankshaft	4	
40	310-955	€12.00 TUBE NUT	4	
41	031-209	€2.52 LOCKWASHER	2	
42	1G2984	€3.24 DOWEL, for clutch cover	2	
43	826-000	€47.04 CYLINDER LINER	4	machining required

Note: Cylinder liners are used to repair damaged bores. The block is bored to accept the liner, liner is pressed into the block, trimmed flush with the block deck, then bored and honed to fit the piston.

45	021-100	€432.00 PISTON SET, std.	1	concave head
	021-101	€432.00 PISTON SET, .020	1	7.5:1 C.R.
	021-102	€422.40 PISTON SET, .030	1	(with rings and pins)
	021-103	€422.40 PISTON SET, .040	1	
	021-110	€432.00 PISTON SET, std.	1	
	021-111	€432.00 PISTON SET, .020	1	100M 8.5:1 C.R.
	021-112	€432.00 PISTON SET, .030	1	concave head
	021-113	€432.00 PISTON SET, .040	1	
46	021-310	€156.36 PISTON RING SET, std.	1	
	021-311	€156.36 PISTON RING SET, .020	1	
	021-312	€152.16 PISTON RING SET, .030	1	4 ring pistons
	021-313	€152.16 PISTON RING SET, .040	1	
	021-314	NA PISTON RING SET, .060	1	
	NA	PISTON RING SET, std.	1	
	NA	PISTON RING SET, .020	1	
	NA	PISTON RING SET, .030	1	5 ring pistons
	NA	PISTON RING SET, .040	1	
	NA	PISTON RING SET, .060	1	
	NA	PISTON RING SET, std.	1	
	NA	PISTON RING SET, .020	1	
	NA	PISTON RING SET, .030	1	100M
	NA	PISTON RING SET, .040	1	
	NA	PISTON RING SET, .060	1	
47	NA	GUDGEON PIN	4	

ill.	Part Number	Price €ea.	Description	Req.	Details
50	031-203	NA	CON ROD	4	
51	2K5681	€1.80	BOLT, clamping rod to gudgeon pin	4	
52	GHF333	€0.72	WASHER, locking	4	
53	320-970	NA	BOLT, for cap (use 320-988)	8	BN1 to (e)213398
	320-988	€46.68	BOLTS, for cap, pair (LH & RH)	4	BN1 from (e)213399, BN2
54	NA	NA	NUT, castellated	8	BN1 to (e)213398
	1K2811	NA	NUT, self-locking (nyloc)	8	BN1 from (e)213399, BN2
56	GHF502	€1.08	SPLIT PIN	8	BN1 to (e)213398
	NA	NA	WASHER	8	BN1 from (e)213399 to C.E.222898
	NA	NA	TAB WASHER	8	BN1 from C.E.222899, BN2
60	8G2051STD	€68.16	CON ROD BEARING SET, std.	1	
	8G2051010	€68.16	CON ROD BEARING SET, .010	1	Tri-metal (copper-lead-tin with babbitt overlay, on steel backing)
	8G2051020	€68.16	CON ROD BEARING SET, .020	1	
	8G2051030	€68.16	CON ROD BEARING SET, .030	1	
	8G2051040	€68.16	CON ROD BEARING SET, .040	1	
	8G2051050	€68.16	CON ROD BEARING SET, .050	1	
	8G2051060	€68.16	CON ROD BEARING SET, .050	1	
61	836-030	NA	OIL PUMP ASSEMBLY	1	with driving spindle #63
62	88G416	€457.20	OIL PUMP ASSEMBLY, standard	1	without driving spindle #63
	836-025	NA	OIL PUMP ASSEMBLY, upgraded	1	without driving spindle #63
63	836-015	€265.20	DRIVING SPINDLE,	1	for pump and tachometer
64	NA	NA	BOLT, cover to body	4	
65	GHF331	€0.84	WASHER, locking	4	
	836-588	€103.56	GEAR SET, oil pump	1	
66	031-214	€43.68	DRIVEN GEAR	1	
67	836-580	€48.36	DRIVING GEAR	1	
	836-588	€103.56	GEAR SET, oil pump	1	
68	327-180	NA	KEY, driving gear	1	
69	NA	NA	PIN, driven gear	1	
	NA	NA	THRUST WASHER	1	
71	836-600	€75.12	PIPE, oil delivery (flexible replacement)	1	
72	836-610	NA	PIPE, oil return	1	
73	836-590	€104.04	OIL STRAINER	1	
74	AJD8105Z	€0.72	NUT	3	
75	GHF332	€0.84	WASHER, locking	3	
80	12H865	€7.92	OIL PRESSURE RELIEF VALVE	1	
81	329-045	€5.16	SPRING	1	
82	328-025	NA	CAP NUT	1	
83	6K431B	€1.44	WASHER, copper	1	
85	021-114	NA	DRIVING SPINDLE, distributor	1	
86	325-250	NA	PEG	1	
87	NA	NA	BUSH, driving spindle	1	
88	320-960	€2.40	SETSCREW, for bush	1	
89	GHF331	€0.84	WASHER, locking	1	
90	NA	NA	DRIVE GEAR ASSEMBLY, tachometer	1	
91	360-591	€154.68	TACHOMETER PINION	1	
92	360-592	€55.92	BUSH	1	
93	1A3073	NA	THRUST WASHER	1	
94	324-215	NA	GASKET, bush to cover	1	
95	835-610	€17.04	RETAINING RING	1	
96	520-440	€5.04	OIL SEAL, pinion	1	
97	021-392	€34.68	PUSHROD, premium quality	8	
98	12B2670	€14.28	TAPPET	8	

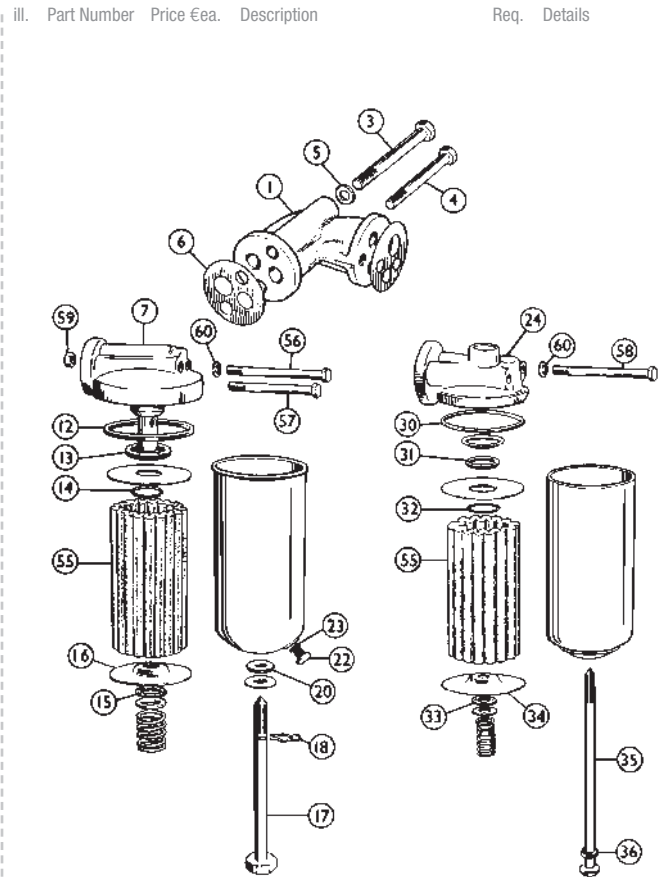

Oil Filters 100-4

1	NA	ADAPTOR, filter head to block	1	BN1 to (e)213324	
	NA	ADAPTOR, filter head to block	1	BN1 from (e)213325, BN2	
3	NA	BOLT, adaptor to block, long	1		
4	NA	BOLT, adaptor to block, short	1		
5	WP9	€2.04	WASHER, plain	2	
6	021-115	€1.68	GASKET, for filter head and block	2	
7	NA	OIL FILTER HEAD, Tecalemit	1		
12	724-005	NA	SEALING RING	1	
13	NA	WASHER, felt	1		
14	NA	CIRCLIP, clamping plate	1		
15	724-030	NA	WASHER, felt	1	
16	NA	PLATE	1	BN1 to (e)207111	
17	NA	BOLT, centre	1		
18	NA	CIRCLIP, for bolt	1		
20	NA	SEALING WASHER	1		
22	NA	DRAIN PLUG	1		
23	NA	WASHER, sealing	1		
24	NA	OIL FILTER HEAD, Tecalemit	1		
30	724-010	NA	SEALING RING	1	
31	724-015	NA	WASHER, felt	1	
32	NA	CIRCLIP, clamping plate	1	BN1 from (e)207112, BN2	
33	2K5820	€1.08	WASHER, felt	1	
34	NA	PLATE	1		
35	NA	BOLT, centre	1		
36	7H1759	€1.08	SEALING WASHER	1	
	NA	OIL FILTER HEAD, Purolator	1		
	NA	SEALING RING	1		
	7H28	€3.00	SEALING WASHER	1	fitted alternatively during production
	NA	SPRING, relief valve	1		
	NA	BOLT, centre	1		
	27H2573	NA	CIRCLIP, for bolt	1	
	500321	NA	SEALING WASHER	1	
55	950-070	NA	OIL FILTER ELEMENT, felt	1	"Crosland" brand
	48G171	€6.48	OIL FILTER ELEMENT, felt	1	various manufacturers
	950-080	NA	OIL FILTER ELEMENT, paper	1	"Crosland" brand
	GFE104	€6.12	OIL FILTER ELEMENT, paper	1	various manufacturers
56	NA	BOLT, long	1	alternative to 58	
57	NA	BOLT, short	1		
58	NA	BOLT, long	2	alternative to 56 & 57	
59	AJD8106Z	€0.96	NUT	2	
60	WP9	€2.04	WASHER, plain	2	

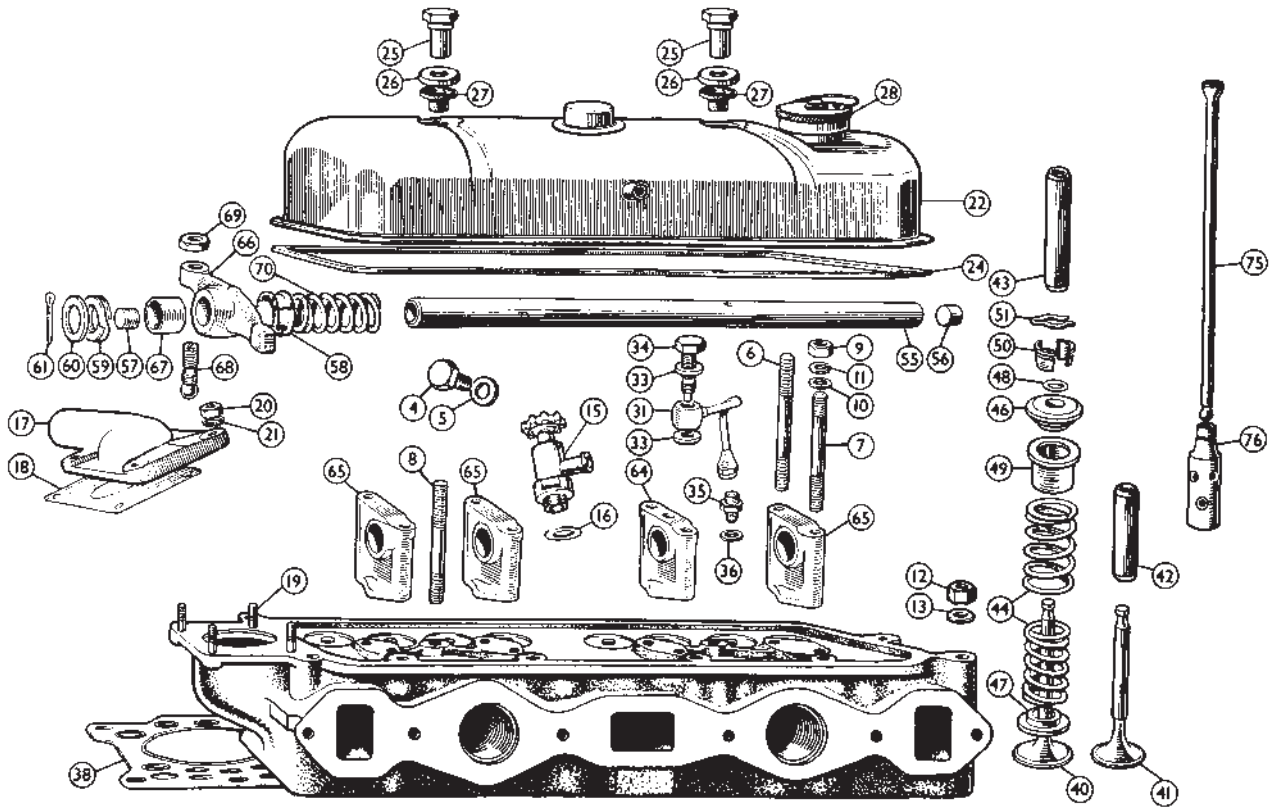

iii. Part Number Price €ea. Description Req. Details

Cylinder Head 100-4

Part Number	Price €ea.	Description	Req.	Details
021-920	€4,147.20	CYLINDER HEAD, aluminium	1	
CB500	€92.64	HEAD GASKET SET	1	
021-056	€51.72	HEAD GASKET	1	
4 AEK122	€12.60	PLUG, heater boss if heater not fitted	1	
5 232043A	€1.68	WASHER	1	
6 328-825	€4.80	STUD, rocker pedestal, long	4	
7 328-815	€5.04	STUD, rocker pedestal, short	4	
8 328-835	€3.96	STUD, rocker cover	2	
9 AJD8106Z	€0.96	NUT	8	
10 WP9	€2.04	WASHER, plain	8	
11 GHF333	€0.72	WASHER, locking	8	
12 2K6995	€4.56	NUT, cylinder head stud	11	
13 GHF303	€0.72	WASHER, plain	11	
15 88G588	€23.16	HEATER CONTROL VALVE	1	
16 AA836	€1.56	WASHER	A/R	
17 835-560	€67.68	WATER OUTLET ELBOW	1	
18 697-320	€1.80	GASKET	1	
19 328-856	€4.56	STUD	4	
20 AJD8105Z	€0.72	NUT	4	
21 GHF332	€0.84	WASHER, locking	4	
22		NA ROCKER COVER, original	1	
852-095	€258.00	ROCKER COVER, aluminium	1	
24 GEG448	€6.96	GASKET, rocker cover, stock type	1	
529-108	€28.68	GASKET, rocker cover, silicone	1	
25 830-260	€19.68	CAP NUT	2	
26 AEC2179	€2.88	CUP WASHER	2	
27 AEC2178	€1.44	BUSH	2	
28 834-850	€59.76	OIL FILLER CAP	1	
31 839-080	€38.28	OIL FEED PIPE	1	
33 WF509	€0.96	WASHER, fibre	2	
34 839-085	€14.16	BOLT, shaft locating	1	
35	NA	UNION, in cylinder head	1	
36 2K4956	€0.84	WASHER, fibre	1	
38 021-056	€51.72	HEAD GASKET (stock type)	1	
40 AEC724	€10.80	VALVE, inlet	4	
41 1B1806	€11.88	VALVE, exhaust	4	
42 021-023	€4.32	VALVE GUIDE, inlet	4	
021-017	€11.52	VALVE GUIDE, inlet, manganese-bronze	4	
43 1B1808	€4.92	VALVE GUIDE, exhaust	4	
021-018	€11.76	VALVE GUIDE, exhaust, manganese-bronze	4	
44 021-026	€50.04	VALVE SPRING SET	1	
46 1B2751	NA	RETAINER, valve spring	8	
47 031-227	NA	VALVE COLLAR, lower	8	
48 021-060	€2.40	OIL SEAL, valve stem	8	
49 031-225	NA	SHROUD, with oil seal and retainer	8	
50 1K800	€5.64	COTTER, valve retaining (set of 2)	8	
51 1K372	€1.32	CIRCLIP	8	
55 021-353	€29.28	ROCKER SHAFT, with plugs	1	
56 328-035	NA	PLUG	1	

iii. Part Number Price €ea. Description Req. Details

57 2K6534	NA	PLUG, threaded	1	
58 839-070	NA	SPACER	1	
59 324-505	NA	SPRING WASHER	2	
60 324-515	NA	WASHER	2	
61 GHF502	€1.08	SPLIT PIN	2	
64 021-356	€46.68	ROCKER PEDESTAL, with tapped hole	1	
65 021-357	€22.08	ROCKER PEDESTAL, without tapped hole	3	
66 AED159	€21.96	ROCKER ARM, with bush	8	
67 11B511	€3.60	BUSH, rocker arm	8	
68 839-060	€15.36	ADJUSTER, rocker arm	8	
69 310-870	NA	LOCKNUT	8	
70 031-229	€3.48	SPRING	3	
75 021-392	€34.68	PUSHROD, premium quality	8	
76 12B2670	€14.28	TAPPET	8	

Note: Rocker arms, pedestals, and pedestal studs are shown "backwards" in the factory drawing above. The photo shows their correct orientation.

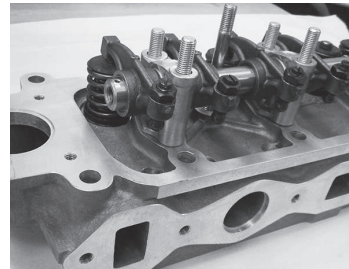

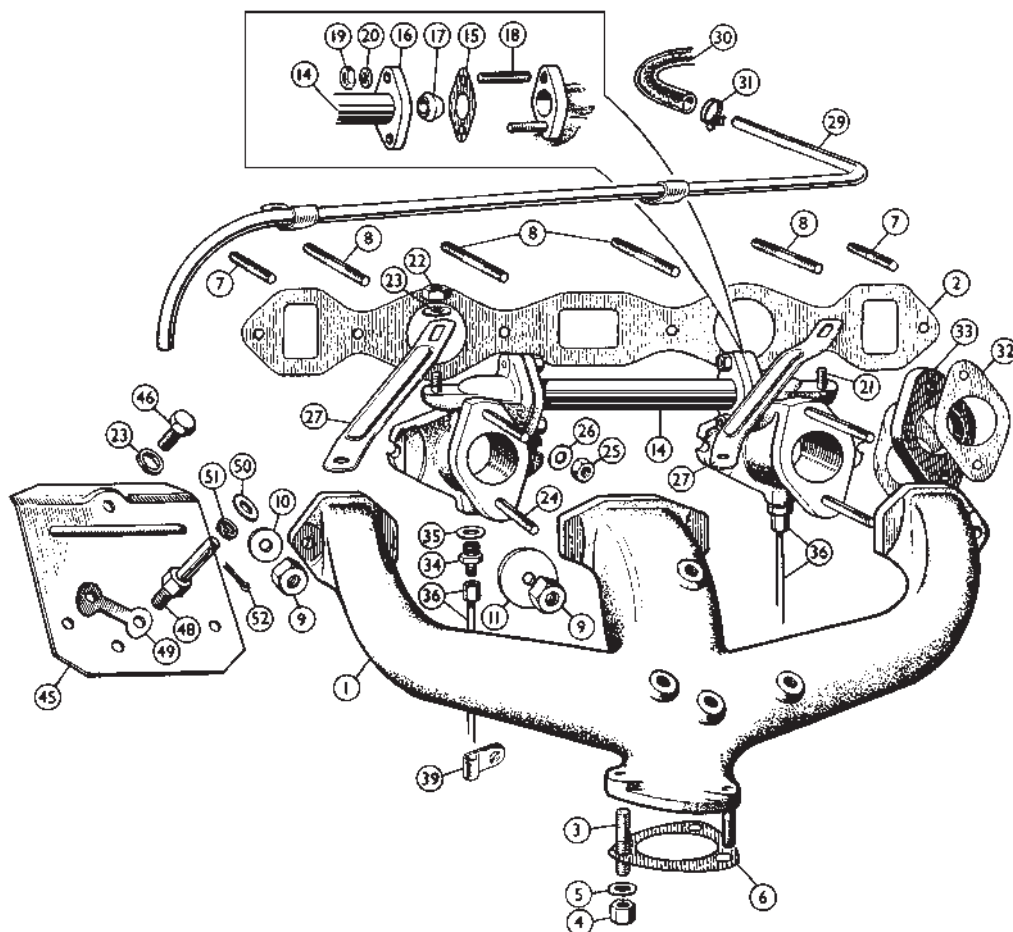

iii. Part Number Price €ea. Description Req. Details

Manifolds 100-4

Part Number	Price €ea.	Description	Req.	Details
1		NA EXHAUST MANIFOLD	1	
2	€5.28	GEG672 MANIFOLD GASKET	1	
3	€2.76	328-795 STUD	3	
4	€3.48	311-015 NUT, brass	3	
5	€0.60	GHF301 WASHER, plain	3	
6		GEK718 NA EXHAUST FLANGE GASKET	1	
7	€4.08	2K3494 STUD, head to exhaust manifold, short	2	
8	€3.72	328-805 STUD, head to exhaust manifold, long	4	
9	€1.92	310-860 NUT, brass	6	
10	€2.04	WP9 WASHER, plain	2	
11	€4.08	324-495 WASHER, yoke	4	
14	€56.76	366-765 BALANCE PIPE	1	
15		NA GASKET, balance pipe to inlet manifolds	2	
16		NA FLANGE, balance pipe gland	1	
17	021-906	NA GLAND, balance pipe	2	
18		NA STUD, balance pipe flange to manifold	4	
19	€1.08	AJD8104 NUT	4	
20	€1.08	GHF300 WASHER, plain	4	
21		NA STUD, outlet pipe to manifold	2	
22	€0.72	AJD8105Z NUT	2	
23	€0.84	GHF332 WASHER, locking	4	
24		NA STUD, manifold to carburettor	4	BN1 to (e)139915
		NA STUD, manifold to carburettor	4	BN1 from (e)139916, BN2
25	€0.96	AJD8106Z NUT	4	
26	€2.04	WP9 WASHER, plain	4	
27	€43.80	376-098 SUPPORT SET, carburettor	1	
29	€59.52	021-908 FEED PIPE, copper	1	
30		NA HOSE, feed pipe to heater	1	
31		NA CLIP, hose	2	
32	€1.56	1G2624 GASKET, carb to manifold	2	BN1 to (e)139915
	€1.56	1G2624 GASKET, carb to manifold	4	BN1 from (e)139915, BN2
33	€8.76	AHH5713 SPACER	2	
34	€7.32	021-431 UNION	2	
35		NA WASHER, fibre	2	
36	€24.48	163-575 DRAIN PIPE ASSEMBLY, replacement	2	must cut to 12"
39		NA CLIP, drain pipe	2	
45	€20.40	021-907 HEAT SHIELD	1	
46		NA BOLT	2	
48	€21.96	728-005 FULCRUM PIN, bellcrank lever	1	
49		NA LOCKTAB	1	
50		NA WASHER, plain	1	
51		NA WASHER, double coil	1	
52	€1.08	GHF502 SPLIT PIN	1	

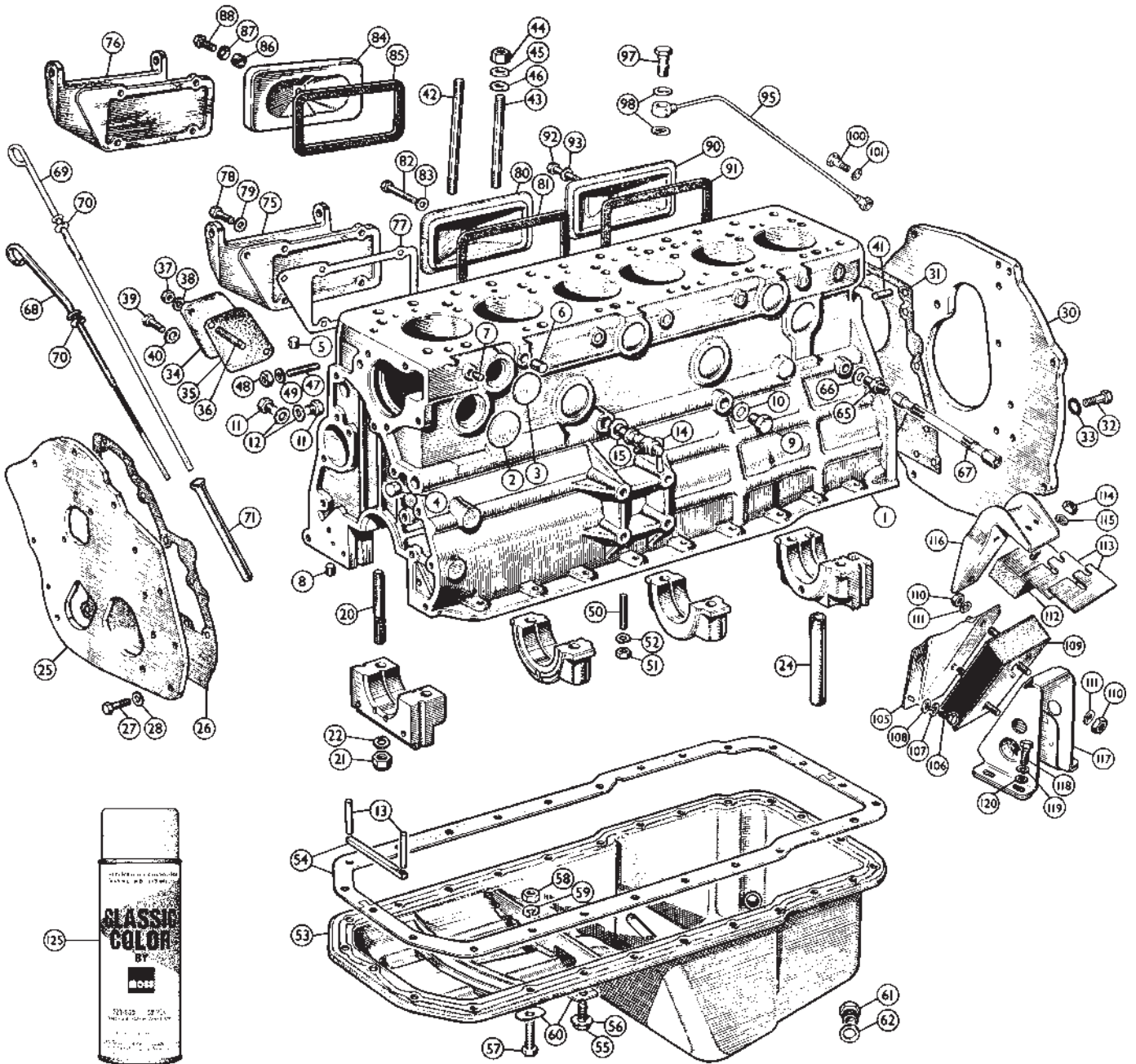

ill.	Part Number	Price €ea.	Description	Req.	Details
External Engine 100-6, 3000					
1	NA		CYLINDER BLOCK	1	
2	2K8169	€1.92	CORE PLUG, steel, dished, 1-5/8"	5	BN4, BN6
	328-231	€4.44	CORE PLUG, brass, dished, 1-5/8"	5	
	AEH592	€2.52	CORE PLUG, steel, cup, 1-41/64"	5	BN7, BT7, BJ7, BJ8
	328-236	NA	CORE PLUG, brass, cup, 1-41/64"	5	
3	2K8160	€2.16	CORE PLUG, dished, 1-5/16"	4	BN4, BN6
	AEC876	€2.88	CORE PLUG, cupped, 1-5/16"	4	
4	NA		PLUG, oil gallery	2	
5	NA		TAPERED PLUG, for oil hole	1	
6	NA		TAPERED PLUG, for water gallery, large	5	
7	NA		TAPERED PLUG, for water gallery, small	2	
8	NA		TAPERED PLUG, for tensioner feeder	1	
9	328-045	€14.76	PLUG, for oil filter feeder hole	1	
10	324-545	€1.20	WASHER, for plug	1	
11	328-081	€1.92	PLUG, for oil pump feed hole	2	
12	324-546	€1.44	WASHER, for plug	2	
13	NA		PLUG, felt, for front & rear main bearing caps	4	
14	3H576	€31.80	DRAIN TAP	1	
15	ARH1499	€1.20	WASHER, for drain tap	A/R	
20	AEC872	€13.20	STUD, main bearing cap	8	
	322-898	€165.12	STUD KIT, high strength (incl. nuts & washers)	1	ARP brand
21	13H4045	€2.88	NUT	8	
22	GHF335	€0.96	WASHER, locking	8	BN4 to C.E.57236
24	NA		DRAIN PIPE, rear bearing cap	1	BN4 to C.E.57181
	NA		DRAIN PIPE, rear bearing cap	1	BN4 from C.E.57182,
					BN6, BN7, BT7, BJ7, BJ8
25	NA		ENGINE MOUNTING PLATE, front	1	BN4, BN6, BN7 & BT7 to
					(e)29D-H26212
	NA		ENGINE MOUNTING PLATE, front	1	BN7 & BT7 from
					(e)29E-H101, BJ7, BJ8
26	NA		GASKET, front plate	1	
27	GHF120	€0.72	BOLT, plate to crankcase	6	
28	GHF332	€0.84	WASHER, locking	6	
30	NA		ENGINE MOUNTING PLATE, rear	1	
31	365-732	€6.12	GASKET, back plate	1	
32	NA		BOLT	11	
33	GHF323	€0.96	WASHER, shakeproof	11	
34	NA		BLANKING PLATE	1	BN4, BN6
35	NA		GASKET	1	
36	NA		STUD	2	
37	GHF201	€0.84	NUT	2	
38	GHF332	€0.84	WASHER, locking	2	
39	NA		BOLT	2	BN7, BT7, BJ7, BJ8 2
40	NA		WASHER, copper	4	
41	1G752	€2.40	DOWEL, backplate to block	2	
42	AEC711	€51.36	STUD, cylinder head, long	8	2 port head
43	AEC604	€10.56	STUD, cylinder head, short	8	
	AEC604	€10.56	STUD, cylinder head, short	16	6 port head

Note: Studs should be installed only finger tight in the engine block to avoid possible cracking into the water jacket.

44	AEC139	€4.44	NUT, cylinder head stud	16	
45	GHF303	€0.72	WASHER, plain	16	
46	724-060	NA	WASHER, bronze	8	2 port head, long studs
47	53K485	€2.52	STUD, water pump to block	4	
48	GHF201	€0.84	NUT	4	
49	GHF332	€0.84	WASHER, locking	4	
50	CHS2510	€3.24	STUD, mounting oil pump to crankcase	3	
51	GHF201	€0.84	NUT	3	
52	GHF332	€0.84	WASHER, locking	3	
53	AEC203	NA	SUMP, steel	1	
	AEC203AL	€422.40	SUMP, alloy	1	
54	GEG524	€14.88	GASKET SET, sump	1	
55	SH604041	€0.84	BOLT, sump to crankcase	25	BN4, BN6
	SH604041	€0.84	BOLT, sump to crankcase	23	
56	GHF321	€1.08	WASHER, shakeproof	23	
57	GHF101	€0.72	BOLT, sump & manifold drain pipe clip to crankcase	2	BN7, BT7, BJ7, BJ8
58	GHF200	€0.96	NUT	2	
59	GHF331	€0.84	WASHER, locking	2	
60	2K5197	€0.84	WASHER, oval	25	
61	2H4685	€10.32	PLUG, oil drain	1	
	2H4685X	€18.00	PLUG, oil drain, magnetic	1	option
62	6K431B	€1.44	WASHER, copper	1	
65	376-800	€17.04	UNION, for oil pressure pipe	1	
66	324-555	€5.76	WASHER, for union	1	
67	AHU1020	€19.80	OIL LINE, flexible	1	
68	021-914	€71.88	DIPSTICK	1	BN4 thru BJ8 to
					(e)29K-H278
69	031-219	€71.88	DIPSTICK	1	BJ8 from (e)29K-H279
70	AEC671	€1.08	WASHER, rubber	1	
71	021-913	NA	TUBE, dipstick	1	
75	835-245	€114.24	SIDE COVER, front	1	BN4, BN6, BN7, BT7, BJ7
76	835-280	€210.48	SIDE COVER, front	1	BJ8
77	AEC313	€1.32	GASKET	1	
78	GHF120	€0.72	BOLT	5	
79	AEC435	€1.20	WASHER, plain	5	
80	12A1386	NA	SIDE COVER, centre, stock type	1	
	460-051	€76.20	SIDE COVER, centre, alloy repl.	1	BN4, BN6, BN7, BT7, BJ7,
81	12A1139	€2.28	GASKET, cork, centre	1	BJ8 to (e)29F-3953
82	BH605101	€2.16	BOLT	1	
83	724-055	NA	WASHER, plain	1	
84	12A1386	NA	SIDE COVER, centre	1	BJ8 from (e)29F-3954

ill.	Part Number	Price €ea.	Description	Req.	Details
85	GUG5505GM	€2.64	GASKET, rubber, centre	1	Can be used on all for
86	12A1176	€2.52	WASHER, sealing	1	improved sealing if used
87	12A1177	€2.04	WASHER, cup	1	as a set
88	SH605091	€1.80	BOLT	1	
90	NA		SIDE COVER, rear	1	
91	12A1139	€2.28	GASKET, cork, rear	1	all
92	BH605101	€2.16	BOLT	1	
93	724-055	NA	WASHER, plain	1	
95	021-260	€54.12	OIL FEED PIPE, tachometer drive	1	
97	021-933	€14.64	BOLT, for union	1	BN4, BN6, BN7, BT7, BJ7
98	324-595	€2.04	WASHER	2	
100	021-934	€11.76	BOLT, for union	1	
101	86K330	€1.56	WASHER	2	
105	NA		FRONT SUPPORT BRACKET	2	BN4, BN6
	NA		FRONT SUPPORT BRACKET, LH	1	BN7, BT7, BJ7, BJ8
	NA		FRONT SUPPORT BRACKET, RH	1	
106	SH606061	€1.44	BOLT, bracket to crankcase	8	
107	GHF333	€0.72	WASHER, locking	8	
108	WP9	€2.04	WASHER, plain	8	
109	ACB9407	€16.32	ENGINE MOUNT	2	
110	GHF203	€0.72	NUT	8	
111	GHF334	€1.32	WASHER, locking	8	
112	1B4428	€9.48	RUBBER BUFFER, engine mounting	2	
113	NA		PACKING PIECE, .048"	A/R	
	NA		PACKING PIECE, .036"	A/R	
114	GHF201	€0.84	NUT	2	
115	GHF332	€0.84	WASHER, locking	2	
116	NA		BRACKET, engine mounting buffer	2	
117	021-423	€173.04	FRONT MOUNTING BRACKET	2	
118	SH606071	€0.84	BOLT, bracket to sidemember	8	
119	GHF333	€0.72	WASHER, locking	8	
120	WP9	€2.04	WASHER, plain	8	
125	CCEP2	€23.04	ENGINE PAINT, metallic green	A/R	12 oz. aerosol
	CCEP3	€23.04	ENGINE PAINT, BMC green	A/R	

Note: Used only on Abingdon built BN4s with 2-port heads.

Gaskets

524-050	€90.96	HEAD GASKET SET	1	BN4 (2 port)
GEG128	€60.00	HEAD GASKET SET	1	BN4 (6 port)BN6, BN7, BJ7, BJ8

Note: Head gasket sets include gaskets for cylinder head, valve cover, manifolds, exhaust flanges, carb. mounting, and valve stem seals.

GEG243	€33.96	CONVERSION GASKET SET (includes all items listed below)	1		
13	NA	PLUG, for front & rear main bearing caps	4		
15	ARH1499	€1.20	WASHER, drain tap	1	
26	NA	GASKET, front plate	1		
31	NA	GASKET, back plate	1		
54	GEG524	€14.88	GASKET SET, sump	1	
	NA	SEAL, ft. & rear main brg. caps	2		
62	6K431B	€1.44	WASHER, copper, sump drain plug	1	
77	AEC313	€1.32	GASKET, front side cover	1	
81	12A1139	€2.28	GASKET, centre and rear side covers	2	
	021-115	€1.68	GASKET, oil filter adaptor plate	2	
	NA	GASKET, oil pump to block	1		
	NA	GASKET, oil pump outlet	1		
	AEC339	€1.44	GASKET, tensioner	1	
	1G1365	€1.80	GASKET, thermostat	1	
	AEC202	€2.40	GASKET, timing cover	1	
	115467X	€2.40	GASKET, water outlet elbow	1	
	88G424	€1.32	GASKET, water pump	1	

Steel Core Plug Sets (complete engine)

328-208	NA	CORE PLUG SET	1	BN4, BN6 2-port head
328-218	NA	CORE PLUG SET	1	BN4, BN6 6-port head
328-228	NA	CORE PLUG SET	1	BN7, BT7, BJ7, BJ8

Ill.	Part Number	Price €ea.	Description	Req.	Details
Internal Engine 100-6, 3000					
1	NA		TIMING COVER	1	
2	AEC202	€2.40	GASKET, timing cover	1	
3	AEC621	€3.96	OIL SEAL, timing cover	1	
4	NA		TIMING POINTER	1	
5	NA		RIVET, for pointer	2	
6	SH605071	€1.20	BOLT, cover to main bearing cap & bracket	7	
7	2K7440	€2.16	WASHER, oval, 5/16"	7	
8	SH604031	€2.28	BOLT, cover to plate	5	
9	2K5197	€0.84	WASHER, oval, 1/4"	5	
10	EAC3629A	€15.00	TENSIONER ASSEMBLY, timing chain	1	
11	AEC339	€1.44	GASKET, tensioner	1	
13	GHF102	€1.08	BOLT, for tensioner	2	
14	AEC340	€2.76	LOCKTAB	1	
15	600-091	€63.12	TIMING CHAIN, heavy duty upgrade	1	
	2H4286	€16.44	TIMING CHAIN	1	
16	832-250	€16.68	DAMPER, chain	1	
17	GHF105	€0.84	BOLT, damper to block	1	BN7 & BT7 from 29E- H101, BJ7, BJ8
18	WP9	€2.04	WASHER, plain	1	
19	GHF333	€0.72	WASHER, locking	1	
20	AEC865	€770.40	CAMSHAFT	1	
			(BJ8 spec. - best cam for all 6-cyl models)		
	851-325	€866.40	CAMSHAFT, 'Works Rally'	1	
21	031-210	€25.68	LOCATING PLATE	1	
22	SH605071	€1.20	BOLT	2	
23	GHF332	€0.84	WASHER, locking	2	
24	AEC482	€82.92	CAMSHAFT GEAR	1	
25	WKN606	€3.48	KEY	1	
26	AEC247	€9.12	NUT	1	
27	1B1219	€3.24	LOCKWASHER	1	
28	AJC6042	€51.60	CAM BEARING SET	1	
29	021-352	€1,353.60	CRANKSHAFT	1	
			(reconditioned with rod & main bearings)		
30	NA		OIL RESTRICTOR	6	
31	031-204	€37.08	STARTING NUT	1	
32	12B681	€6.84	LOCKTAB	1	
33	NA		PULLEY, crankshaft	1	BN4, BN6, BN7, BT7, BJ7,
34	NA		DAMPER, for pulley	1	BJ8 to 29K/H10271
35	NA		PULLEY & DAMPER, crankshaft	1	BJ8 from 29K/H10272
Nos. 33-35 are not available. We suggest using replacement no. SC6622, shown on facing page.					
36	SC6622	€585.60	PULLEY & DAMPER, crankshaft	1	all models replacement
37	322-180	NA	BOLT, damper to pulley	6	BN4, BN6, BN7, BT7, BJ7
38	GHF333	€0.72	WASHER, locking	6	BJ8 to 29K/H10271
39	837-070	€9.24	OIL THROWER	1	
40	AEC2026	€44.40	CRANKSHAFT GEAR	1	
41	145276	€2.04	SHIM	A/R	
42	WKN608	€2.40	KEY	2	
43	1K369	€5.16	SPIGOT BUSH	1	
44	8G2360STD	€82.80	MAIN BEARING SET, std.	1	
	8G2360010	€82.80	MAIN BEARING SET, .010	1	Tri-metal (copper-lead-tin
	8G2360020	€82.80	MAIN BEARING SET, .020	1	with babbitt overlay, on
	8G2360030	€82.80	MAIN BEARING SET, .030	1	steel backing)
	8G2360040	€82.80	MAIN BEARING SET, .040	1	
45	BHM3000	€12.36	THRUST WASHER SET, std.	1	
	BHM3000/5	€13.80	THRUST WASHER SET, .005	1	
	NA		THRUST WASHER SET, .010	1	
46	NA		FLYWHEEL ASSEMBLY	1	BN4, BN6
	NA		FLYWHEEL ASSEMBLY	1	BN7, BT7, BJ7 to 29F/H4878
	NA		FLYWHEEL ASSEMBLY	1	BJ7 from 29F/H4879, BJ8
47	1B1714	€53.40	RING GEAR	1	
48	138527	€4.08	BOLT, flywheel, stock type	4	
	322-191	€9.96	BOLT, flywheel	4	ARP high strength replacement
49	310-960	€8.16	NUT	4	
50	031-209	€2.52	LOCKTAB	2	
51	1G2984	€3.24	DOWEL	2	BN4, BN6, BN7 & BT7 to 29D-H254732
	NA		DOWEL	2	BN7 & BT7 from 29D- H25474, BJ7 to 29F-H4878
	NA		DOWEL	3	BJ7 from 29F-H4879, BJ8
55	021-302	NA	CYLINDER LINER	6	BN4, BN6
	AEC879	€34.20	CYLINDER LINER	6	BN7, BT7, BJ7, BJ8
Note: Cylinder liners are used to repair damaged bores. The block is bored to accept the liner, liner is pressed into block, trimmed flush with block deck, then bored and honed to fit the piston.					
56	021-266	NA	PISTON SET, std.	1	
	021-267	NA	PISTON SET, .020	1	BN4 to C.E.40500 (clamp
	021-268	NA	PISTON SET, .030	1	type rods; 2639cc)
	021-269	NA	PISTON SET, .040	1	
	021-290	€603.60	PISTON SET, std.	1	
	021-292	€603.60	PISTON SET, .020	1	BN4 from C.E. 40501, BN6
	021-293	€603.60	PISTON SET, .030	1	(bush type rods; 2639cc)
	021-294	€603.60	PISTON SET, .040	1	
	8G2576	€429.60	PISTON SET, std.	1	
	8G2576/20	€429.60	PISTON SET, .020	1	BN7, BT7, BJ7, BJ8 (bush
	8G2576/30	€429.60	PISTON SET, .030	1	type rods; 2912cc)
	8G2576/40	€429.60	PISTON SET, .040	1	
	8G2576/60	€429.60	PISTON SET, .060	1	
57	567-052	€160.68	PISTON RING SET, std., (4 ring)	1	
	021-316	€137.76	PISTON RING SET, .020, (4 ring)	1	
	021-317	€174.12	PISTON RING SET, .030, (4 ring)	1	BN4, BN6
	021-318	€140.88	PISTON RING SET, .040, (4 ring)	1	
	021-319	NA	PISTON RING SET, .060, (4 ring)	1	

Ill.	Part Number	Price €ea.	Description	Req.	Details
	8G2577	€187.32	PISTON RING SET, std., (5 ring)	1	BN7, BT7, BJ7, BJ8
	8G2577/20	€187.32	PISTON RING SET, .020, (5 ring)	1	compression rings are
	8G2577/30	€187.32	PISTON RING SET, .030, (5 ring)	1	.078" thick
	817-740	€123.72	PISTON RING SET, .040, (5 ring)	1	
	8G2577/60	€187.32	PISTON RING SET, .060, (5 ring)	1	
	567-180	€142.44	PISTON RING SET, std., (4 ring)	1	BN7, BT7, BJ7, BJ8
	021-321	€143.76	PISTON RING SET, .020, (4 ring)	1	compression rings are
	021-322	€184.32	PISTON RING SET, .030, (4 ring)	1	.094" thick
	021-323	€159.00	PISTON RING SET, .040, (4 ring)	1	
	021-324	NA	PISTON RING SET, .060, (4 ring)	1	
	8G2522STD	€150.48	PISTON RING SET, std., (5 ring)	1	BN7, BT7, BJ7, BJ8
	817-520	€177.60	PISTON RING SET, .020, (5 ring)	1	compression rings are
	8G2522/30	€150.48	PISTON RING SET, .030, (5 ring)	1	.094" thick
	817-540	€199.08	PISTON RING SET, .040, (5 ring)	1	
	817-560	NA	PISTON RING SET, .060, (5 ring)	1	
58	NA		PISTON PIN, std.	6	bushed type rods
59	045985	€3.60	CIRCLIP	12	
60	837-780	NA	CON ROD, pistons 1, 3 & 5	3	
	837-790	NA	CON ROD, pistons 2, 4 & 6	3	BN4 to C.E.40500
61	322-200	NA	BOLT, clamping rod to gudgeon pin	6	
62	GHF333	€0.72	WASHER, locking	6	
63	8G2339/10	NA	CON ROD, new	6	BN4 from C.E. 40501,
	MM021-628	NA	CON ROD, reconditioned	6	BN6, BN7, BT7, BJ7, BJ8
64	829-018	€19.32	BUSH SET, con rod	1	
65	021-636	NA	BOLT, con rod cap	12	BN4, BN6, BN7/BT7 thru (e)29E-H928
	021-633	€21.00	BOLT, con rod cap	12	BN7/BT7 from (e)29E-H929, BJ7, BJ8
66	AEC328	€3.36	NUT	12	
70	AJC5159STD	€84.60	CON ROD BEARING SET, std.	1	
	AJC5159010	€84.60	CON ROD BEARING SET, .010	1	Tri-metal (copper-lead-tin
	AJC5159020	€84.60	CON ROD BEARING SET, .020	1	with babbitt overlay, on
	AJC5159030	€84.60	CON ROD BEARING SET, .030	1	steel backing)
	AJC5159040	€84.60	CON ROD BEARING SET, .040	1	
72	AEC692	€192.60	OIL PUMP ASSEMBLY, standard, rotor & vane type	1	
	021-363	€232.20	OIL PUMP ASSEMBLY, high volume	1	BN4, BN6, BN7 & BT7 to (e) 29D-H894 (may use later pump)
73	NA		DRIVING SHAFT, with inner & outer rotors	1	
74	NA		BOLT	4	
75	GHF331	€0.84	WASHER, locking	4	
80	AEC1341	€195.72	OIL PUMP ASSEMBLY, standard, gear type	1	
	021-373	NA	OIL PUMP ASSEMBLY, high volume	1	
81	021-421	€10.80	DRIVEN SHAFT	1	
82	021-426	€19.68	DRIVING SHAFT	1	
	836-588	€103.56	GEAR SET, oil pump	1	BN7 & BT7 from
83	031-214	€43.68	DRIVEN GEAR	1	(e)29D-H895, BJ7, BJ8
84	836-588	€103.56	GEAR SET, oil pump	1	
85	WKN405	€1.80	KEY, driving gear	1	
86	NA		BOLT, cover to body	4	
87	GHF300	€1.08	WASHER, plain	4	
88	GHF331	€0.84	WASHER, locking	4	
89	NA		DRIVING SPINDLE	1	BN4 to C.E.38262
	031-216	€160.68	DRIVING SPINDLE	1	BN4 from C.E.38263, BN6, BN7, BT7, BJ7, BJ8
90	021-422	€8.64	THRUST WASHER	1	
91	NA		OIL STRAINER	1	
92	GHF117	€0.72	BOLT	3	
93	GHF300	€1.08	WASHER, plain	3	
94	GHF331	€0.84	WASHER, locking	3	
95	NA		GASKET, pump to block	1	included in conversion
96	NA		GASKET, oil pump outlet	1	gasket set
97	NA		STUD, mounting oil pump to block	3	
98	GHF201	€0.84	NUT	3	
99	GHF332	€0.84	WASHER, locking	3	
100	1K141	NA	PIPE, valve drain	1	
102	AEC283	€11.64	OIL PRESSURE RELIEF VALVE	1	
103	AEC284	€3.00	SPRING	1	
104	328-025	NA	CAP NUT	1	
105	6K431B	€1.44	WASHER, copper	1	
106	NA		HOUSING, distr. & tach drive	1	
107	NA		BOLT	2	
108	GHF331	€0.84	WASHER, locking	2	
109	GHF300	€1.08	WASHER, plain	2	
110	NA		BOLT	3	
111	GHF331	€0.84	WASHER, locking	3	
112	021-315	NA	DRIVING GEAR, distributor	1	
113	021-339	NA	DRIVING DOG	1	
114	021-320	NA	EXTENSION, for drive spindle	1	BN4, BN6, BN7, BT7, &
115	325-250	NA	PEG, for spindle	1	BJ7 thru (e)29FG3562
116	021-330	€117.48	DRIVING GEAR, tachometer	1	(cars w/ mechanical tach)
117	325-250	NA	PEG, for gear	1	
118	021-333	€185.16	TACHOMETER PINION	1	
119	1A3073	NA	THRUST WASHER	1	
120	021-334	€99.00	BUSH	1	
121	324-585	€0.72	GASKET	1	
122	520-440	€5.04	OIL SEAL, pinion	1	
123	835-610	€17.04	RETAINING RING	1	
125	AEC681	€3.96	OIL SEAL, distributor	1	
126	NA		DISTRIBUTOR HOUSING	1	
127	SH604051	€0.72	BOLT	1	
128	GHF321	€1.08	WASHER, shakeproof	1	
129	NA		DRIVING GEAR, distributor	1	BJ7 from (e)29FG3563, BJ8
130	NA		COUPLING, distributor to gear	1	
131	NA		CIRCLIP	1	
135	88G264	€6.12	PUSHROD	12	
136	AEC264	€19.32	TAPPET	12	

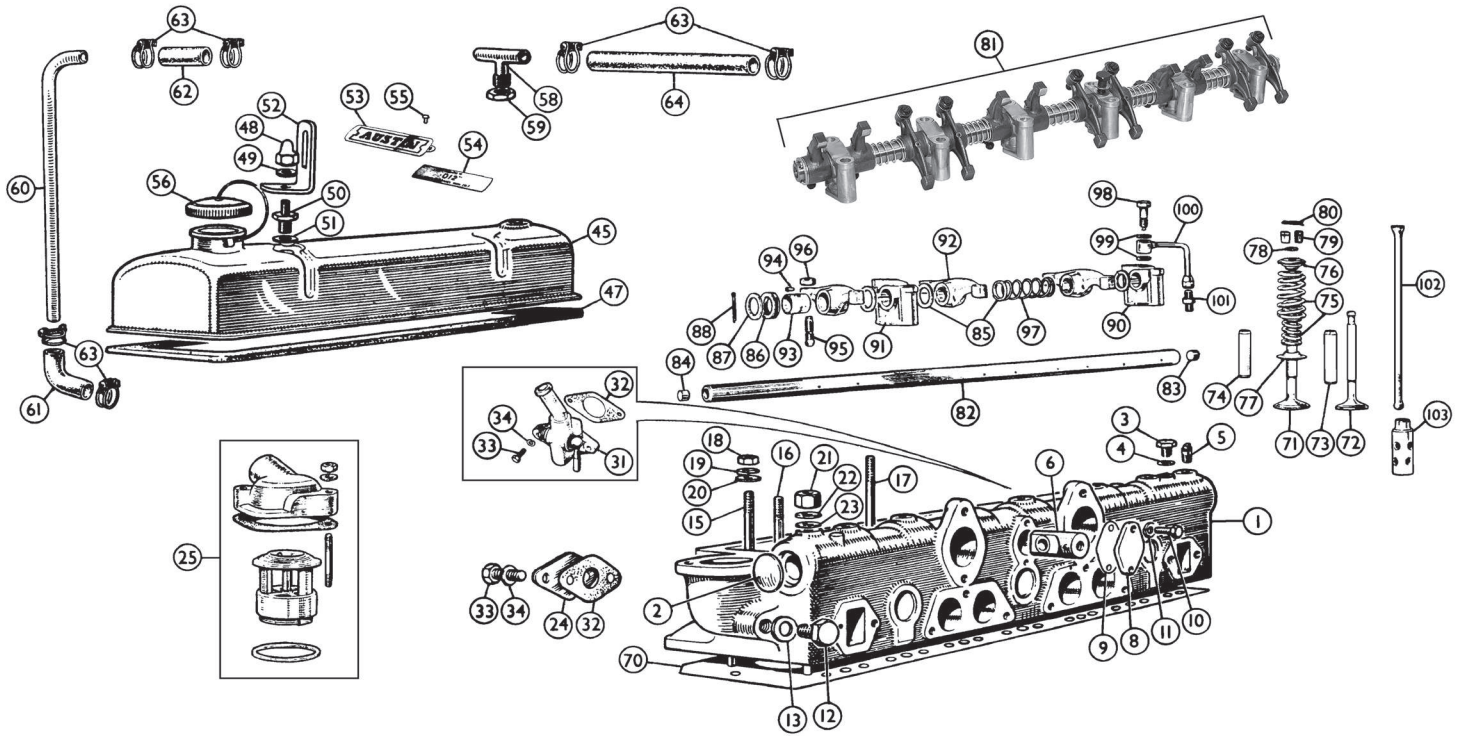

Part Number	Price €ea.	Description	Req.	Details
Cylinder Head 100-6 (2 Port)				
1	NA	CYLINDER HEAD	1	
524-050	€90.96	HEAD GASKET SET	1	
2	€2.16	CORE PLUG, dished, 1-5/16"	6	
3	NA	PLUG, for servo boss	1	
4	€3.24	WASHER	1	
5	NA	PLUG, for vacuum take off	1	
6	NA	BALANCE PLUG	1	
	NA	PEG	1	
8	NA	COVER, for plug	1	
9	NA	GASKET	1	
10	NA	BOLT	2	
11	GHF332	€0.84 WASHER, locking	2	
12	NA	PLUG	1	
13	6K433	€3.24 WASHER	1	
15	51K591	€7.08 STUD, rocker pedestal, long	6	
16	51K590	€5.76 STUD, rocker pedestal, short	4	
17	AEC491	€5.64 STUD, rocker pedestal and rocker cover 2	2	
18	GHF202	€0.72 NUT	12	
19	WP9	€2.04 WASHER, plain	12	
20	GHF333	€0.72 WASHER, locking	12	
21	AEC139	€4.44 NUT, cylinder head stud	16	
22	GHF303	€0.72 WASHER, plain	16	
23	724-060	NA WASHER, bronze	16	
24	NA	BLANKING PLATE, heater valve	1	
25	NA	THERMOSTAT ASSEMBLY	1	see page 23
31	835-620	€90.60 HEATER CONTROL TAP	1	
32	12H3868	€1.08 GASKET	1	
33	SH604051	€0.72 BOLT	2	
34	GHF331	€0.84 WASHER, locking	2	
45	031-233	NA ROCKER COVER, stock type	1	
	852-105	€268.80 ROCKER COVER, aluminium (script top)	1	
	852-100	€235.80 ROCKER COVER, aluminium (plain top)	1	
47	GEG418	€9.96 GASKET, rocker cover, stock type	1	
	529-104	€39.12 GASKET, rocker cover, silicone	1	stock covers
	529-106	€39.84 GASKET, rocker cover, silicone	1	alloy covers
48	310-900	NA CAP NUT	2	
49	WP9	€2.04 WASHER, plain	2	
50	794-000	NA ADAPTOR, for nut	2	
51	324-525	NA WASHER, plain	2	
52	12A1968	€8.64 LIFTING EYE BRACKET	2	fit only when lifting engine
53	CRCP348	€8.64 ALLOY PLATE, Austin	1	
54	CRB191	€13.56 BRASS PLATE, valve clearance	1	.012" hot
55	AHA9999	€0.84 RIVET, for plates	4	
56	8G612	€11.88 OIL FILLER CAP, with cable	1	
	8G612CP	€13.92 OIL FILLER CAP, chrome, without cable	1	
58	794-010	€95.64 VENT PIPE, polished stainless steel	1	
59	310-930	NA LOCKNUT	1	
60	021-427	€19.20 CRANKCASE VENT PIPE	1	
61	280-180	€17.16 ELBOW, for pipe	1	
62	12B703	€2.16 HOSE	1	

Part Number	Price €ea.	Description	Req.	Details
63	CS4016	€2.52 CLIP, hose (wire type)	6	
64	12B702	€12.36 HOSE, vent pipe to air filter	1	
70	528-035	€185.16 HEAD GASKET, copper, premium quality	1	
	GEG322	€37.44 HEAD GASKET, aftermarket	1	
71	021-020	€12.72 INLET VALVE	6	
72	537-087	€9.24 EXHAUST VALVE, 1.415-1.420" head dia.	6	
73	AEC135	€5.16 VALVE GUIDE, inlet	6	
	021-062	€10.68 VALVE GUIDE, inlete	6	manganese-bronze
74	AEC245	€4.32 VALVE GUIDE, exhaust	6	
	021-061	€10.68 VALVE GUIDE, exhaust	6	manganese-bronze
75	12B1344K	€48.48 VALVE SPRING SET	1	
76	12H992	€4.08 CAP, valve spring	12	
77	1H726	€5.16 VALVE COLLAR	12	
78	AEK113	€0.72 OIL SEAL, valve stem	12	
79	1K800	€5.64 COTTER, valve retaining (set of 2)	12	
80	1K372	€1.32 CIRCLIP	12	
81	852-140	€787.20 ROCKER ASSEMBLY	1	
82	AEC272	€64.08 ROCKER SHAFT, with plugs	1	
83	328-035	NA PLUG	1	
84	2K6534	NA PLUG, threaded	1	
85	324-575	€0.96 WASHER, rocker spacing	12	
86	324-505	NA SPRING WASHER	2	
87	324-565	€1.08 WASHER	2	
88	GHF502	€1.08 SPLIT PIN	2	
90	021-358	€41.04 ROCKER PEDESTAL, with tapped hole	1	
91	021-357	€22.08 ROCKER PEDESTAL, without tapped hole	5	
92	AED159	€21.96 ROCKER ARM, with bush	12	
93	11B511	€3.60 BUSH, rocker arm	12	
94	5C2436	NA RIVET	12	
95	031-230	€12.96 ADJUSTER, rocker arm	12	
96	NT606041	€1.08 LOCKNUT	12	
97	031-229	€3.48 SPRING	5	
98	835-220	€13.44 BANJO BOLT	1	
99	324-760	€2.52 WASHER	2	
100	839-090	€32.16 OIL FEED PIPE, with union and nut	1	
101	835-225	€7.56 UNION	1	
102	88G264	€6.12 PUSHROD	12	
103	AEC264	€19.32 TAPPET	12	

Note: These hoses are not fabric covered as were the originals.

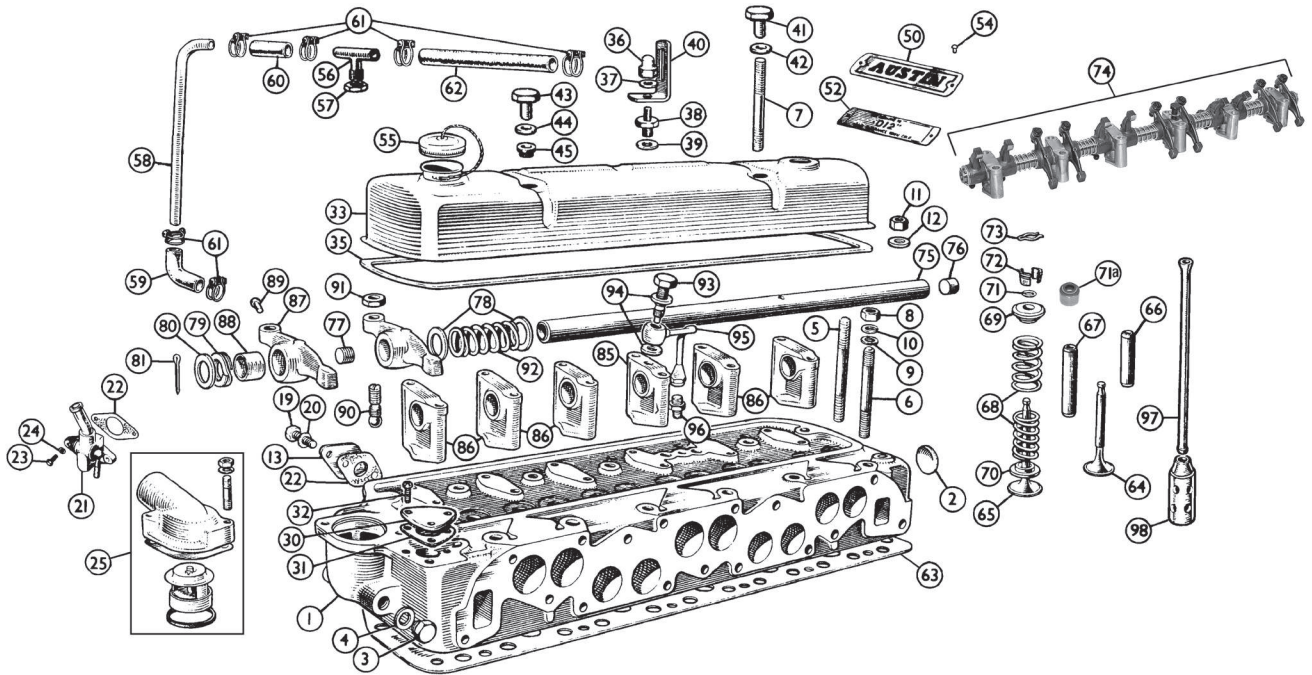

Part Number	Price €ea.	Description	Req.	Details
Cylinder Head 100-6, 3000 (6 Port)				
1 021-950	€5,222.40	CYLINDER HEAD, aluminium	1	
GEG128	€60.00	HEAD GASKET SET	1	
2 2K8160	€2.16	CORE PLUG, dished, 1 5/16"	1	BN4, BN6
AEC876	€2.88	CORE PLUG, cupped, 1 5/16"	1	BN7, BT7, BJ7, BJ8
3	NA	PLUG, thermal indicator boss	1	
4 6K433	€3.24	WASHER	1	
5 51K591	€7.08	STUD, rocker pedestal, long	6	
6 51K590	€5.76	STUD, rocker pedestal, short	4	
7 AEC491	€5.64	STUD, rocker pedestal and rocker cover	2	
8 GHF202	€0.72	NUT	12	
9 WP9	€2.04	WASHER, plain	12	
10 GHF333	€0.72	WASHER, locking	12	
11 AEC139	€4.44	NUT, cylinder head stud	16	
12 GHF303	€0.72	WASHER, plain	16	
13	NA	BLANKING PLATE, heater valve	1	
19 SH604041	€0.84	BOLT, for blanking plate	2	when heater is not fitted
20 GHF331	€0.84	WASHER, locking	2	
21 835-620	€90.60	HEATER CONTROL TAP	1	
22 12H3868	€1.08	GASKET	1	
23 SH604051	€0.72	SCREW	2	
24 GHF331	€0.84	WASHER, locking	2	
25	NA	THERMOSTAT ASSEMBLY	1	see page 23
30	NA	BLANKING PLATE	1	BN7 & BT7 from
31 236022A	€3.72	GASKET	1	(e)29D-H2864, BJ7, BJ8
32 PMZ308	€0.72	SCREW	3	
33	NA	ROCKER COVER, stock	1	
852-105	€268.80	ROCKER COVER, alloy, script top	1	
852-100	€235.80	ROCKER COVER, alloy, plain top	1	
35 GEG418	€9.96	GASKET, rocker cover, stock type	1	
529-104	€39.12	GASKET, rocker cover, silicone	1	stock covers
529-106	€39.84	GASKET, rocker cover, silicone	1	alloy covers
36 310-900	NA	CAP NUT	2	
37 WP9	€2.04	WASHER, plain	2	
38 794-000	NA	ADAPTOR, for nut	2	BN4
39 324-525	NA	WASHER, plain	2	
40 12A1968	€8.64	LIFTING EYE BRACKET	2	
41 310-920	€24.12	CAP NUT	2	BN6, BN7 & BT7 to 29E-
42 324-525	NA	WASHER, plain	2	H630 (for original valve covers)
43 324-538	€12.00	CAP WASHER (polished stainless steel)	1	BN4, BN6, BN7, BT7, BJ7, BJ8
310-920	€24.12	CAP NUT, stock type	2	BN7, BT7 from 29E-H631, 29E-H631, BJ7, BJ8 (for original valve covers)
44 AEC2179	€2.88	CUP WASHER, stock type	2	
45 AEC2178	€1.44	BUSH, rubber	2	
50 CRCP348	€8.64	ALLOY PLATE, Austin	1	BN4 - BJ8 to (c)33500
CRST136	€4.32	MYLAR DECAL, Austin	1	BJ8 from (c)33500
52 CRB191	€13.56	BRASS PLATE, .012" hot	1	BN4 - BJ7
NA	ALUMINIUM PLATE, 0.12" cold	1	BJ8 to (c)33500	
CRST154	€8.64	MYLAR DECAL, .012" cold	1	BJ8 from (c)33500
54 AHA9999	€0.84	RIVET, for plates	4	
55 8G612	€11.88	OIL FILLER CAP, with cable	1	
8G612CP	€13.92	OIL FILLER CAP, chrome, without cable	1	
56 794-010	€95.64	VENT PIPE, polished stainless steel	1	

Part Number	Price €ea.	Description	Req.	Details
57 310-930	NA	LOCKNUT	1	
58 021-427	€19.20	CRANKCASE VENT PIPE	1	
59 280-180	€17.16	ELBOW, for pipe	1	
60 12B703	€2.16	HOSE, vent pipe	1	
61 CS4016	€2.52	CLIP, hose (wire type)	6	
62 12B702	€12.36	HOSE, vent pipe to air filter	1	
63 528-035	€185.16	HEAD GASKET, copper, premium quality	1	
GEG322	€37.44	HEAD GASKET, aftermarket	1	
64 AEC724	€10.80	INLET VALVE	6	
65 AEC915	€15.84	EXHAUST VALVE, stainless steel	6	stellite tip, 1.565" head dia.
66 AEC135	€5.16	VALVE GUIDE, inlet	6	
021-062	€10.68	VALVE GUIDE, inlet, manganese-bronze	6	
67 AEC245	€4.32	VALVE GUIDE, exhaust	6	
021-061	€10.68	VALVE GUIDE, exhaust, manganese-bronze	6	
68 12B1344K	€48.48	VALVE SPRING SET	1	
69 12H992	€4.08	CAP, valve spring	12	
70 1H726	€5.16	VALVE COLLAR	12	
71 AEK113	€0.72	SEAL, valve stem, original o-ring type	12	
71a 290-901	€3.96	SEAL, valve stem, umbrella type (option)	12	
72 1K800	€5.64	COTTER, valve retaining (set of 2)	12	
73 1K372	€1.32	CIRCLIP	12	
74 852-140	€787.20	ROCKER ASSEMBLY	1	
75 AEC272	€64.08	ROCKER SHAFT, with plugs	1	
76 328-035	NA	PLUG	1	
77 2K6534	NA	PLUG, screwed	1	
78 324-575	€0.96	WASHER, rocker spacing	12	
79 324-505	NA	SPRING WASHER	2	
80 324-565	€1.08	WASHER	2	
81 GHF502	€1.08	SPLIT PIN	2	
85 021-358	€41.04	ROCKER PEDESTAL, with tapped hole	1	
86 021-357	€22.08	ROCKER PEDESTAL, without tapped hole	5	
87 AED159	€21.96	ROCKER ARM, with bush	12	
88 11B511	€3.60	BUSH, rocker arm	12	
89 5C2436	NA	RIVET	12	
90 031-230	€12.96	ADJUSTER, rocker arm	12	
91 NT606041	€1.08	LOCKNUT	12	
92 031-229	€3.48	SPRING	5	
93 835-220	€13.44	BANJO BOLT	1	
94 324-760	€2.52	WASHER	2	
95 839-090	€32.16	OIL FEED PIPE, with union and nut	1	
96 835-225	€7.56	UNION	1	
97 88G264	€6.12	PUSHROD	12	
98 AEC264	€19.32	TAPPET	12	

Note: These hoses are not fabric covered as were the originals.

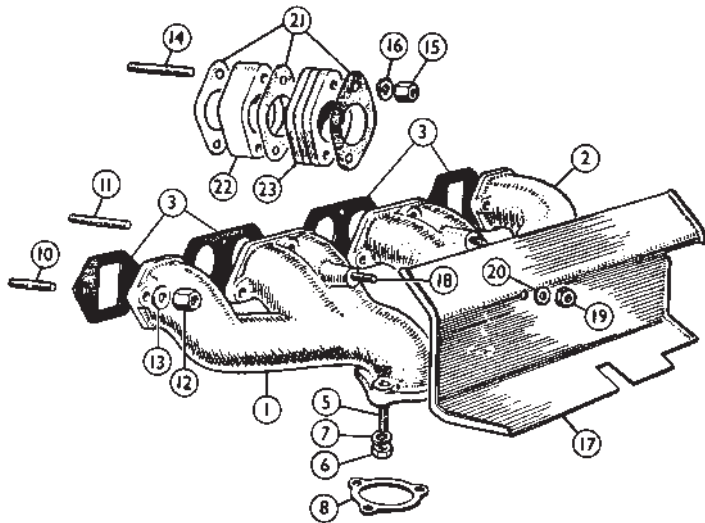

ill. Part Number Price €ea. Description Req. Details

Manifolds 100-6 (2 port)

1	NA		EXHAUST MANIFOLD, front	1	
2	NA		EXHAUST MANIFOLD, rear	1	
3	021-055	€17.16	MANIFOLD GASKET SET	1	(4 manifold gaskets)
5	FHS2513	€1.92	STUD, stock type	6	
6	GHF261	€0.96	NUT, brass	6	
7	GHF332	€0.84	WASHER, locking	6	
8	GEG706	€7.44	EXHAUST FLANGE GASKET	2	
10	724-070	€2.64	STUD, head to exhaust manifold, short	8	
11	NA		STUD, head to exhaust manifold, long	2	
12	AEC350	€3.60	NUT, brass	10	
13	WP9	€2.04	WASHER, plain	10	
14	NA		STUD, head to carburettor	4	
15	GHF202	€0.72	NUT	4	
16	GHF333	€0.72	WASHER, locking	4	
17	370-105	€79.92	HEAT SHIELD	1	
18	NA		STUD	2	
19	GHF261	€0.96	NUT, brass	2	
20	GHF300	€1.08	WASHER, plain	2	
21	AEH551	€1.80	GASKET, manifold to carburettor	4/6	qty increased for heater
22	NA		SPACER, aluminium	2	
23	NA		INSULATING BLOCK	2	not req'd. when heater fitted
	NA		INDUCTION HEATER	1	

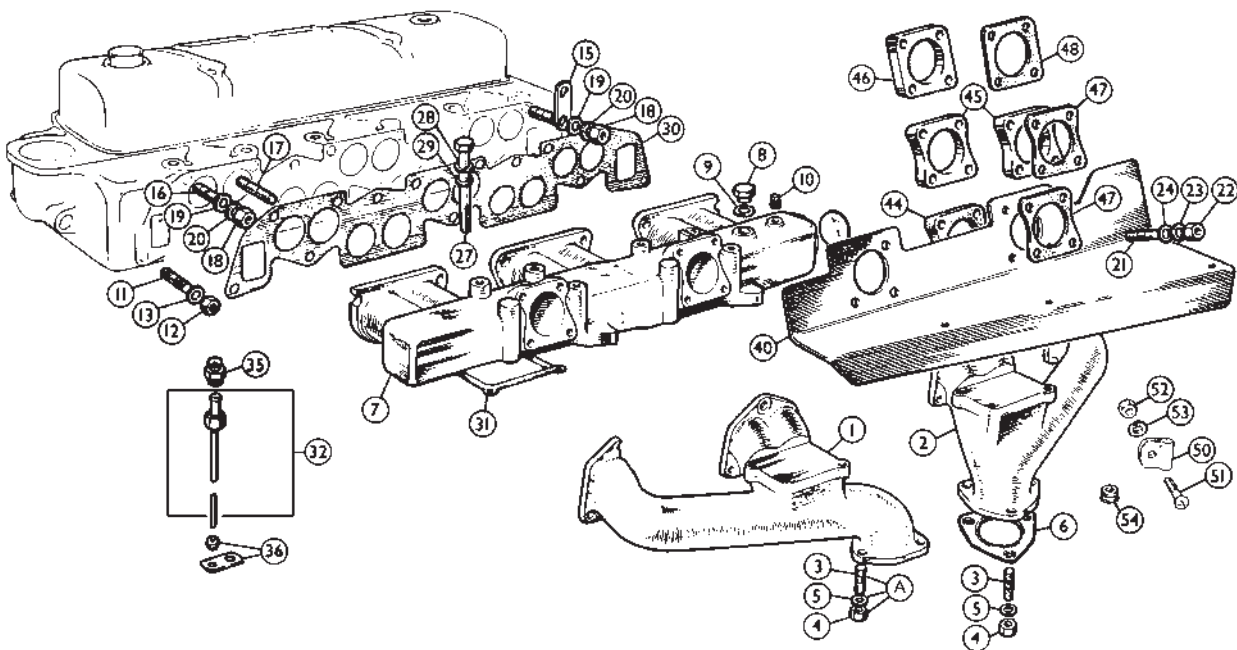

iii. Part Number Price €ea. Description

Req. Details

Manifolds 100-6, 3000 (6 port, twin carb)

Part Number	Price €ea.	Description	Req.	Details
1	NA	EXHAUST MANIFOLD, front	1	BN4 from C.E.48863, BN6
	NA	EXHAUST MANIFOLD, front	1	BN7, BT7, BJ7, BJ8
2	NA	EXHAUST MANIFOLD, rear	1	BN4 from C.E.48863, BN6
	NA	EXHAUST MANIFOLD, rear	1	BN7, BT7, BJ7, BJ8
3	FHS2513	€1.92 STUD, stock type	6	
4	GHF261	€0.96 NUT, brass	6	
5	GHF301	€0.60 WASHER, plain	6	
6	GEG706	€7.44 EXHAUST FLANGE GASKET	2	
7	021-960	€1,027.20 INLET MANIFOLD, replacement	1	BN4 thru BJ8
	NA	INLET MANIFOLD	1	BN4, BN6
	NA	INLET MANIFOLD	1	BN7 & BT7 to 29D-H2863
	NA	INLET MANIFOLD	1	BN7 & BT7 from 29D-H2864 to 6394
	NA	INLET MANIFOLD	1	BN7 & BT7 from 29D-H6395 to 26212
	NA	INLET MANIFOLD	1	BJ7
	NA	INLET MANIFOLD	1	BJ8
8	NA	PLUG, for servo boss	1	BN4 from C.E.48863, BN6, BN7, BT7
	NA	PLUG, for servo boss	1	BJ7, BJ8
9	6K433	€3.24 WASHER	1	BN4 from C.E.48863, BN6, BN7, BT7
	1B3664	€0.96 WASHER	1	BJ7, BJ8
10	NA	PLUG, for vacuum take off	1	BN4 from C.E.48863, BN6, BN7, BT7, BJ7
11	53K564	€2.64 STUD, head to exhaust manifold	10	
12	AEC350	€3.60 NUT, brass	10	
13	WP9	€2.04 WASHER, plain	10	
15	725-025	NA CLIP, thermo capillary pipe	1	BN6 from (e)66673, BN7, BT7, BJ7, BJ8
	724-038	€11.64 CLIP (w/non-used grommet)	1	BN7, BJ7, BJ8
16	53K562	€4.56 STUD, head to inlet manifold, short	7	BN4, BN6 to (e)66673
	53K562	€4.56 STUD, head to inlet manifold, short	5	BN6 from (e)66673, BN7, BT7
	53K562	€4.56 STUD, head to inlet manifold, short	6	BJ7, BJ8
17	53K563	€3.36 STUD, head to inlet manifold, long	2	BN6 from (e)66673 & BN7, BT7
	53K563	€3.36 STUD, head to inlet manifold, long	1	BJ7, BJ8
18	GHF202	€0.72 NUT	7	BN6 from (e)66673, BN7, BT7, BJ7, BJ8
19	WP9	€2.04 WASHER, plain	7	
20	GHF333	€0.72 WASHER, locking	7	
21	CHS2516	€3.72 STUD, manifold to carb.	8	BN4 from C.E.48863, BN6, BN7, BT7, BJ7
	724-090	NA STUD, manifold to carb.	8	BJ8
22	GHF201	€0.84 NUT	8	
23	GHF332	€0.84 WASHER, locking	8	
24	GHF301	€0.60 WASHER, plain	8	
27	BH605261	€2.64 BOLT, inlet to exhaust	4	BN7, BT7, BJ7, BJ8
28	GHF332	€0.84 WASHER, locking	4	
29	GHF301	€0.60 WASHER, plain	4	
30	GEG624	€8.28 GASKET, manifolds to head	1	
31	021-429	€2.76 GASKET, inlet to exhaust manifold	4/2	BN4 from C.E.48863, BN6 to C.E.66442
	021-429	€2.76 GASKET, inlet to exhaust manifold	2	BN6 from C.E.66443, BN7, BT7, BJ7, BJ8

iii. Part Number Price €ea. Description

Req. Details

Part Number	Price €ea.	Description	Req.	Details
32	794-020	€16.80 PIPE ASSEMBLY, petrol drain for manifold	2	
35	021-431	€7.32 UNION	2	
36	724-038	€11.64 CLIP & RUBBER GROMMET SET	2	
	724-040	NA CLIP	2	
	NA	GROMMET, rubber, for clip	2	
40	372-105	€74.40 HEAT SHIELD	1	BN4 from C.E.48863, BN6, BN7, BT7, BJ7
	372-106	€68.28 INSULATION SET, w/rivets	1	
	372-115	€74.40 HEAT SHIELD	1	
44	112866	€5.76 SPACER	2	BN4 from C.E.48863, BN6, BN7, BT7, BJ7
45	GUG705602GM	€20.52 SPACER	4	BJ7
46	696-070	€25.56 SPACER	2	BJ8
47	112867	€1.20 GASKET, heat shield to carb.	A/R	BN4 from C.E.48863, BN6, BN7, BT7, BJ7
48	C7221	€1.20 GASKET, heat shield to carb.	4	BJ8
50	725-005	NA CLIP, rear overflow pipe	1	
51	PMZ307	€1.20 SCREW	1	BN4 from C.E.56201, 52
52	GHF206	NA NUT	1	BN6, BN7 & BT7 to (e)29D-H2863
53	GHF331	€0.84 WASHER, locking	1	
54	725-020	NA GROMMET, overflow pipe	1	BN4 from C.E.56201, BN6, BN7, BT7
	724-038	€11.64 GROMMET (w/unused clip)	1	
	725-010	NA GROMMET, overflow pipe	1	BJ8

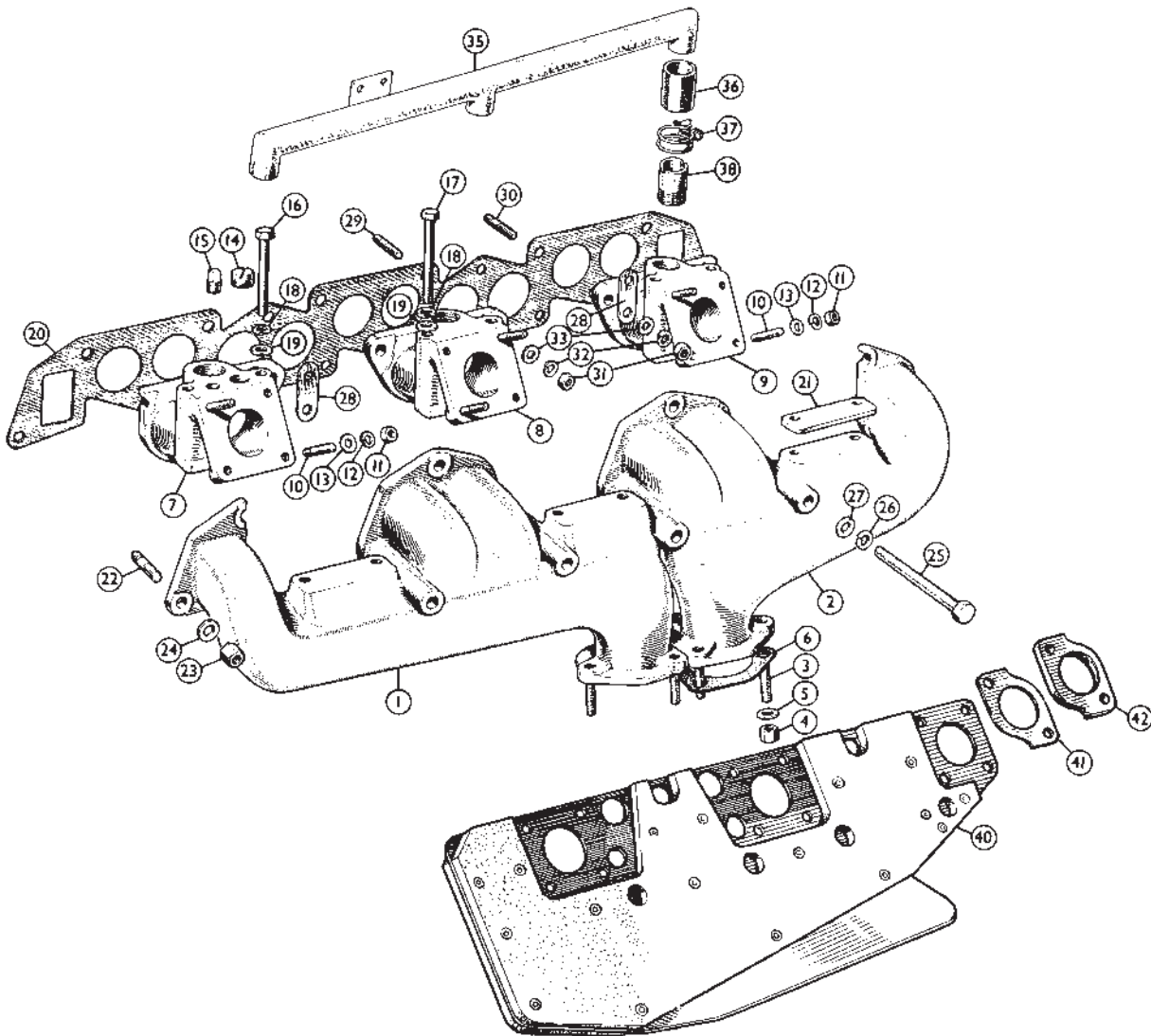

Part Number	Price €ea.	Description	Req.	Details
Manifolds 3000 (triple carbs)				
1	NA	EXHAUST MANIFOLD, front	1	
2	NA	EXHAUST MANIFOLD, rear	1	
3	FHS2513	€1.92 STUD	6	
4	GHF261	€0.96 NUT, brass	6	
5	GHF301	€0.60 WASHER, plain	6	
6	GEG706	€7.44 EXHAUST FLANGE GASKET	2	
7	NA	INLET MANIFOLD, front	1	to 29E-H928 (c)15103
8	NA	INLET MANIFOLD, centre	1	
9	NA	INLET MANIFOLD, rear	1	
10	NA	STUD, manifold to carburettor	6	from 29E-H929 (c)15104
	NA	INLET MANIFOLD, front	1	
	NA	INLET MANIFOLD, centre	1	
	NA	INLET MANIFOLD, rear	1	
	CHS2513	€2.40 STUD, manifold to carburettor	6	
11	GHF201	€0.84 NUT	6	
12	GHF332	€0.84 WASHER, locking	6	
13	GHF301	€0.60 WASHER, plain	6	
14	NA	PLUG, for servo boss	1	
15	NA	PLUG, for vacuum take off	1	
16	BH605281	€2.76 BOLT, inlet to exhaust, short	4	
17	NA	BOLT, inlet to exhaust, long, centre manifold	2	
18	GHF332	€0.84 WASHER, locking	6	
19	GHF301	€0.60 WASHER, plain	6	
20	GEG624	€8.28 GASKET, manifolds to head	1	
21	021-433	€2.52 GASKET, inlet to exhaust manifold	3	
22	724-070	€2.64 STUD, head to exhaust manifold	6	
23	AEC350	€3.60 NUT, brass	6	
24	WP9	€2.04 WASHER, plain	6	
25	NA	BOLT, head to exhaust manifold	4	
26	GHF333	€0.72 WASHER, locking	4	
27	WP9	€2.04 WASHER, plain	6	
28	724-038	€11.64 CLIP, thermo capillary pipe	2	(w/unused grommet)
29	53K562	€4.56 STUD, head to inlet manifold, short	5	
30	53K563	€3.36 STUD, head to inlet manifold, long	2	
31	GHF202	€0.72 NUT	7	
32	GHF333	€0.72 WASHER, locking	7	
33	WP9	€2.04 WASHER, plain	7	

Part Number	Price €ea.	Description	Req.	Details
35	NA	PIPE, balance, non-servo models, 3/4"	1	
36	021-434	NA HOSE, balance pipe, 3/4"	3	
37	CS4020	€2.76 CLIP, hose	6	
38	NA	ADAPTOR, balance pipe	3	to 29E-H928
40	372-125	€105.72 HEAT SHIELD	1	
41	AEC2083	€1.08 GASKET, heatshield	6	
35	NA	PIPE, balance, servo fitted models, 1"	1	
36	021-435	NA HOSE, balance pipe, 1"	3	
37	CS4023	€2.76 CLIP, hose	6	
38	NA	ADAPTOR, balance pipe	3	from 29E-H929
40	372-125	€105.72 HEAT SHIELD	1	
	372-126	NA SPACER SET, w/ rivets	1	
42	696-050	€28.56 SPACER	3	
	AEC2083	€1.08 GASKET, heatshield	3	

Note: The earlier heatshield had one layer of insulating material, while the later one had two, as shown in the drawing above. Ours include two, but may be assembled with one, if desired.

**VOKES
(Early BN4)**

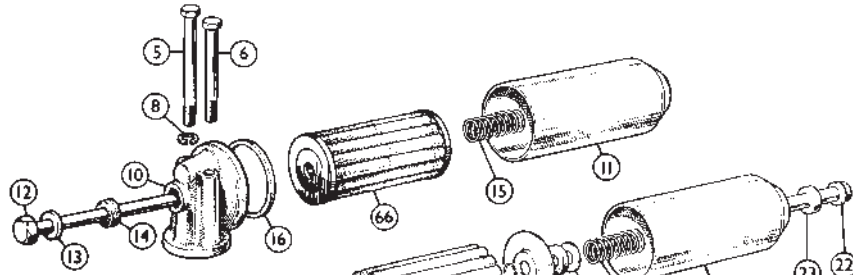

**TECALEMIT
(Early)**

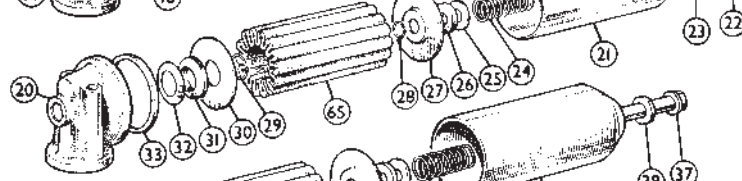

**TECALEMIT
(Late)**

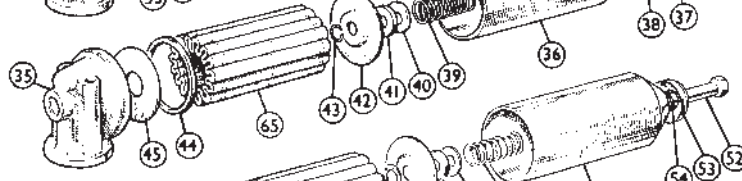

PUROLATOR

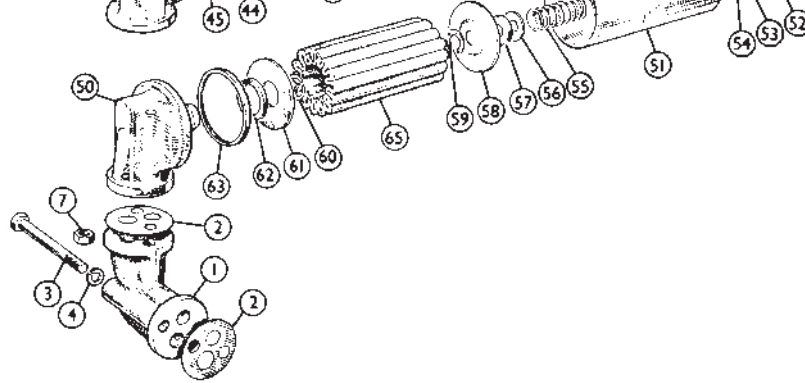

Part Number	Price €ea.	Description	Req.	Details	
1		NA ADAPTOR ELBOW	1		
2	021-115	€1.68 GASKET, adaptor plate	2		
3		NA BOLT, adaptor plate to block	2		
4	GHF333	€0.72 WASHER, locking	2		
5		NA BOLT, oil filter to adaptor plate, long	1		
6		NA BOLT, oil filter to adaptor plate, short	1		
7	GHF202	€0.72 NUT	1		
8	GHF333	€0.72 WASHER, locking	2		
10		NA OIL FILTER HEAD, Vokes*	1	Vokes-BN4	
11		NA CANNISTER, oil filter	1		
12		NA BOLT	1		
13		NA WASHER, plain	1		
14		NA WASHER, rubber	1		
15		NA SPRING	1		
16	021-469	NA SEALING RING	1		
20		NA OIL FILTER HEAD, Tecalemit BSF thread*	1		
		NA OIL FILTER HEAD, Tecalemit UNF thread*	1		
21		NA CANNISTER, oil filter	1		
22		NA BOLT, BSF thread	1		
		NA BOLT, UNF thread	1		
		NA WASHER, rubber	1		
23	021-468		1		Tecalemit-BN4, BN6, BN7, BT7, BJ7 to 29F-H2268
24	7H1764	€5.04 SPRING	1		
25	7H1765	€1.08 WASHER, plain	1		
26	2K5820	€1.08 WASHER, felt	1		
27	17H846	€18.96 PRESSURE PLATE	1		
28	1K372	€1.32 CIRCLIP, for bolt	1		
29		NA CIRCLIP, for plate	1		
30		NA PLATE, for element	1		
31	021-474	NA WASHER, felt	1		
32		NA WASHER, dished	1		
33	13H998	€2.76 SEALING RING	1	Tecalemit-BJ7 from 29F-H2269, BJ8	
35		NA OIL FILTER HEAD, Tecalemit*	1		
36		NA CANNISTER, oil filter	1		
37		NA BOLT, centre	1		
38	37H1173	€1.80 WASHER, rubber	1		
39	7H1764	€5.04 SPRING	1		
40	7H1765	€1.08 WASHER, plain	1		
41	2K5820	€1.08 WASHER, felt	1		
42	17H846	€18.96 PRESSURE PLATE	1		
43	1K372	€1.32 CIRCLIP, for bolt	1		
44	13H998	€2.76 SEALING RING	1		
45	021-438	NA PLATE, for element	1		

Part Number	Price €ea.	Description	Req.	Details	
50		NA OIL FILTER HEAD, Purolator*	1	Purolator (alternative to Vokes for Tecalemit)	
51		NA CANNISTER, oil filter	1		
52		NA BOLT, centre	1		
53		NA COLLAR	1		
54	508380	€3.36 O RING	1		
55	500319	NA SPRING, pressure plate	1		
56	WP9	€2.04 WASHER, plain	1		
57	7H28	€3.00 WASHER, rubber	1		
58	17H846	€18.96 PRESSURE PLATE	1		
59	1K372	€1.32 CIRCLIP, for bolt (replacement)	1		
60		NA SNAP RING	1	these do not fit Vokes system	
61		NA PLATE, for element	1		
62	021-476	NA GASKET	1		
63	12A1591	€2.40 SEAL	1		
65	950-070	NA OIL FILTER, felt, "Crosland" brand	1		
	48G171	€6.48 OIL FILTER, felt, various manufacturers	1		
	950-080	NA OIL FILTER, paper, "Crosland" brand	1		
	GFE104	€6.12 OIL FILTER, paper, various manufacturers	1		
66		NA OIL FILTER ELEMENT	1		Vokes system

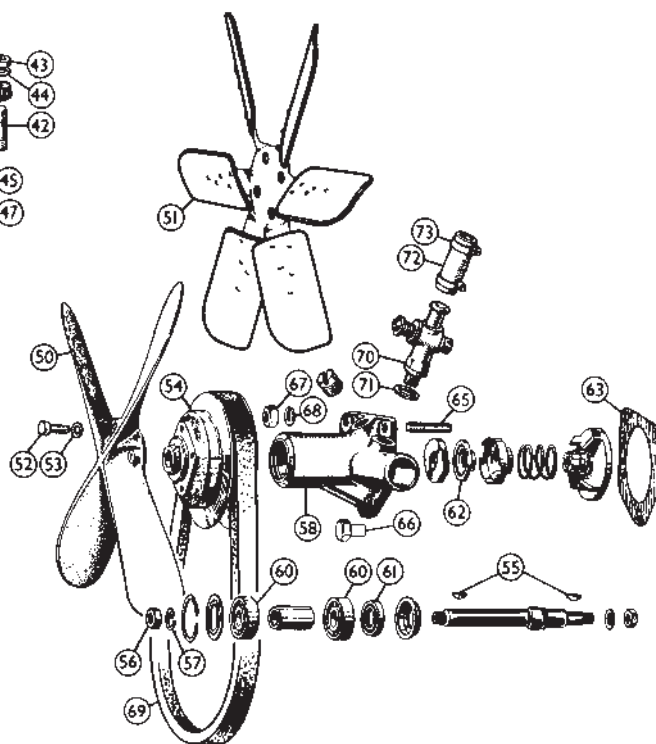
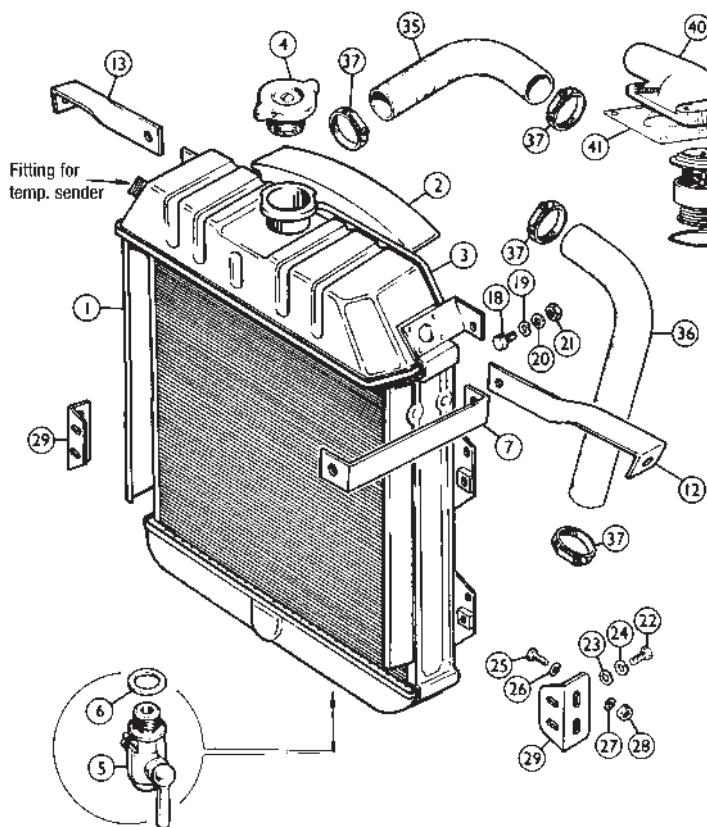

iii. Part Number Price €ea. Description Req. Details

Cooling 100-4

Part Number	Price €ea.	Description	Req.	Details
1	NA	RADIATOR ASSEMBLY	1	
2	€49.92	FAN SHROUD	1	
3	€5.28	OVERFLOW PIPE	1	
4	€5.16	RADIATOR CAP, 4 psi	1	normal
GRC103SS	€9.00	RADIATOR CAP, 4 psi, stainless steel	1	normal
GRC101	€5.16	RADIATOR CAP, 7 psi	1	raises boiling temp.
GRC101SS	€8.64	RADIATOR CAP, 7 psi, stainless steel	1	raises boiling temp.
5	€24.24	DRAIN TAP (replica)	1	
6	€1.20	SEALING WASHER, 1/16"	A/R	
7	€17.64	TIE BRACKET, front, LH	1	
834-970	€37.08	TIE BRACKET, front, RH	1	
12	NA	TIE BRACKET, to LH wheelarch	1	
13	NA	TIE BRACKET, to RH wheelarch	1	
18	€0.84	BOLT	2	
19	€0.84	WASHER, locking	2	
20	€1.08	WASHER, plain	2	
21	€0.96	NUT	2	
22	NA	BOLT, radiator to support bracket	2	
23	€1.20	WASHER, plain	2	
24	€0.84	WASHER, locking	2	
25	NA	BOLT, support bracket to chassis	4	
26	€0.60	WASHER, plain	4	
27	€0.84	WASHER, locking	4	
28	€0.84	NUT	4	
29	€19.68	RADIATOR SUPPORT BRACKET	2	
35	NA	RADIATOR HOSE, top	1	
021-063	€16.44	RADIATOR HOSE, top, premium	1	
36	€25.20	RADIATOR HOSE, bottom	1	
37	€3.96	CLIP, hose (wire type)	4	
14G800	€6.48	CLIP, hose (strap type)	4	
40	€67.68	WATER OUTLET ELBOW	1	
41	€1.80	GASKET	1	
42	NA	STUD	4	
43	€0.72	NUT	4	
44	€0.84	WASHER, locking	4	
45	€126.96	THERMOSTAT, 72°C (160°F), with sleeve	1	reproduction of original (for stock systems using 4 psi or 7 psi. radiator caps)
GTS102	€7.44	THERMOSTAT, 74°C (165°F), summer	1	modern replacement (no sleeve)
GTS104	€7.92	THERMOSTAT, 82°C (180°F), standard	1	
GTS106	€9.24	THERMOSTAT, 90°C (195°F), winter	1	
47	€1.80	GASKET, thermostat	1	
50	NA	FAN, cast alloy	1	
51	€105.72	FAN, 6 blade	1	hot climates
52	€2.64	BOLT, to pulley	4	
53	€0.84	WASHER, locking	4	
54	€67.32	PULLEY	1	
55	NA	KEY	2	
56	NA	NUT	1	
57	€1.32	WASHER, locking	1	
58	€114.24	WATER PUMP, upgraded	1	

iii. Part Number Price €ea. Description Req. Details

(with hose nipple at heater tap location. Original heater tap will not fit.)

Part Number	Price €ea.	Description	Req.	Details
SC1303	€81.24	WATER PUMP, replacement	1	
(with hose nipple at heater tap location. Original heater tap will fit.)				
60	€21.96	BEARING*	2	
61	NA	OIL SEAL*	1	
62	031-223	NA SEAL*	1	
63	€1.44	GASKET, water pump to block	1	
65	NA	STUD	3	
66	€9.84	NUT, shouldered (special - 3/8 BSF, 9/16" across flats)	2	
67	AJD8106Z	€0.96 NUT, plain	1	
68	GHF333	€0.72 WASHER, locking	3	
69	2H4238	€17.16 FAN BELT, original type	1	
021-966	€15.48	FAN BELT, cogged	1	
70	3H641	€121.80 HEATER TAP, at water pump	1	
71	324-485	NA WASHER	1	
72	682-050	NA HOSE, tap to outlet pipe	1	
73	725-030	NA CLIP	2	

Note: pump components will fit original pumps only.

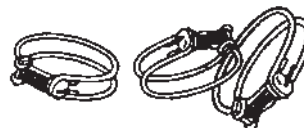

Original Type Hose Clamps

These wire-type clamps are similar to the original clamps used on most Austin-Healeys. Zinc plated for long-lasting looks and durability, they're necessary for a correct restoration. Just measure the outside diameter of your hoses to determine which ones you need.

CS4009	€3.00	7/16" to 9/16"
CS4012	€2.16	9/16" to 3/4"
CS4013	€2.28	5/8" to 13/16"
635-345	NA	11/16" to 7/8"
CS4016	€2.52	3/4" to 1"
326-490	NA	13/16" to 1-1/16"
CS4020	€2.76	1" to 1-1/4"
635-355	NA	1-1/8" to 1-3/8"
CS4023	€2.76	1-1/4" to 1-7/16"
635-330	NA	1-5/16" to 1-1/2"
CS4025	€3.00	1-3/8" to 1-9/16"
CS4026	€3.96	1-7/16" to 1-5/8"
CS4029	€3.96	1-5/16" to 1-13/16"
CS4030	€2.76	1-11/16" to 1-7/8"
CS4032	€3.96	1-7/8" to 2"
CS4034	€3.96	1-15/16" to 2-1/8"
CS4036	€2.28	2-1/16" to 2-1/4"
CS4038	€2.64	2-3/16" to 2-7/16"
CS4042	€2.16	2-7/16" to 2-5/8"

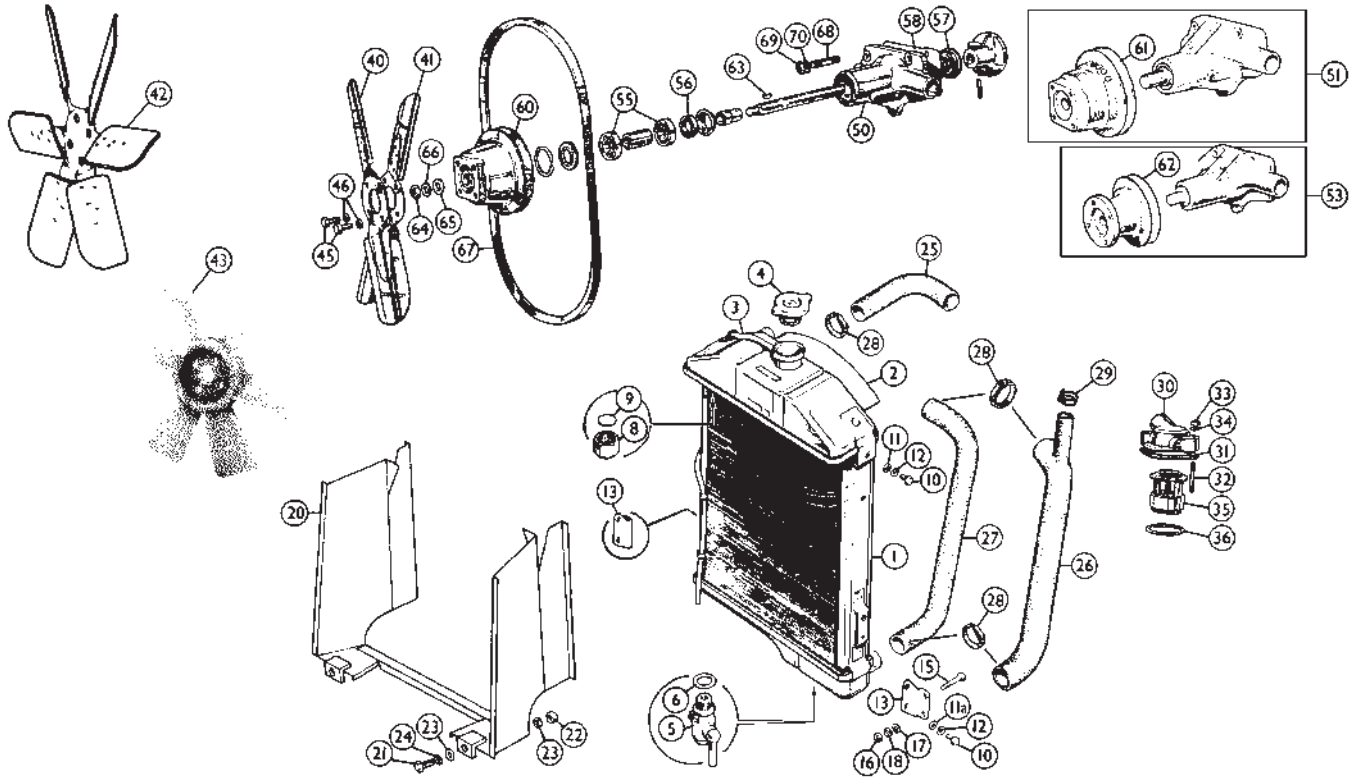

ill.	Part Number	Price €ea.	Description	Req.	Details
Cooling 100-6, 3000					
1	834-990	€864.00	RADIATOR ASSEMBLY	1	
	834-990AL	€807.60	RADIATOR ASSEMBLY, aluminium	1	
2	806-420	€56.04	FAN SHROUD	1	
3	021-306	€5.28	OVERFLOW PIPE	1	
4	GRC101	€5.16	FILLER CAP, 7psi	1	
	GRC101SS	€8.64	FILLER CAP, 7psi, stainless steel	1	
5	ARH1050	€24.24	DRAIN TAP (replica)	1	
6	ARH1499	€1.20	SEALING WASHER, 1/16" thick	A/R	
		NA	SEALING WASHER, 3/32" thick	A/R	
8	NA		PLUG, radiator tank	1	BN4 from C.E.31099 RHD
9	NA		WASHER	1	& C.E.31281 LHD, BN6, BN7, BT7, BJ7, BJ8
10	SH605051	€1.80	BOLT	6	
11	PWZ205	€0.72	WASHER, plain, upper	4	BJ7, BJ8
11a	GHF301	€0.60	WASHER, lower	4	all
12	GHF332	€0.84	WASHER, locking	6	
13	834-992	€17.52	RADIATOR SUPPORT BRACKET PAIR	1	
15	NA		BOLT, bracket to suspension support	4	
16	GHF201	€0.84	NUT	4	
17	GHF301	€0.60	WASHER, plain	4	
18	GHF332	€0.84	WASHER, locking	4	
20	806-330	€221.04	AIR DEFLECTOR ASSEMBLY	1	BN4 from C.E.47184 RHD & C.E.47191 LHD, BN6, BN7 & BT7 to (c)13750
	806-340	€65.64	AIR DEFLECTOR ASSEMBLY	1	BN7 & BT7 from (c)13751 BJ7, BJ8
21	GHF117	€0.72	BOLT	2	
22	GHF200	€0.96	NUT	2	
23	NA		WASHER, plain	4	
24	GHF331	€0.84	WASHER, locking	2	
25	GRH314	€17.16	RADIATOR HOSE, top	1	
26	GRH475	€33.96	RADIATOR HOSE, bottom	1	when heater is fitted
27	AHB8970	€25.56	RADIATOR HOSE, bottom	1	when heater is not fitted
28	CS4026	€3.96	CLIP, hose (wire type)	4	
	14G800	€6.48	CLIP, hose strap type	4	orig. through approx. 1962
29	CS4016	€2.52	CLIP, bottom hose to heater take-off	1	wire type
30	AEC158	€22.44	WATER OUTLET ELBOW	1	
31	115467X	€2.40	GASKET, "Klingersil"	1	
32	FHS2515	€2.40	STUD	2	
33	GHF201	€0.84	NUT	2	
34	GHF332	€0.84	WASHER, locking	2	
35	107590	€126.96	THERMOSTAT, 72°C (160°F), with sleeve	1	reproduction of original (for stock systems using 4 lb. or 7 lb. radiator caps)
	GTS102	€7.44	THERMOSTAT, 74°C (165°F), summer	1	modern replacement
	GTS104	€7.92	THERMOSTAT, 82°C (180°F), standard	1	(no sleeve)
	GTS106	€9.24	THERMOSTAT, 90°C (195°F), winter	1	
36	1G1365	€1.80	GASKET, thermostat	1	
40	834-870	NA	FAN BLADE, front	1	

ill.	Part Number	Price €ea.	Description	Req.	Details
41	834-875	NA	FAN BLADE, rear	1	
42	AEC76	€112.56	FAN, 6-blade "tropical"	1	option
43	834-887	€58.08	FAN, "Texas Cooler 2"	1	
			(Mount with flat washers 365-720 under bolts)		
45	SH605071	€1.20	BOLT, to pulley	4	
46	GHF332	€0.84	WASHER, locking	4	
50	GWP107	NA	WATER PUMP, 3/8" pulley groove	1	(for 5-1/4" dia. pulley)
			(This pump is not available. Use 835-020 as a replacement)		BN4, BN6, BN7 & BT7 to 29E-H2245
51	GWP112	€91.32	WATER PUMP, 3/8" pulley groove	1	(with 4-1/2" dia. pulley)
					BN7, BT7 from 29EH2246, BJ7, BJ8 to 29K-H10271
53	GWP110	€82.80	WATER PUMP, with 1/2" pulley	1	BJ8 from 29K-H10272
55	6K803	€21.96	BEARING	2	BN4, BN6, BN7 & BT7 to 29E-H2245
56	NA		OIL SEAL	1	
57	NA		SEAL	1	
58	88G424	€1.32	GASKET, water pump to block	1	
60	834-995	NA	PULLEY, bolt-on type, 3/8" belt	1	
61	835-035	€47.16	PULLEY, press-on type, 3/8" belt	1	
62	835-065	NA	PULLEY, press-on type 1/2" belt	1	(pulley looks similar to illustration #61.)
63	327-195	NA	KEY	1	BN4, BN6, BN7 & BT7 to 29E-H2245
64	NT607041	€1.80	NUT	1	
65	GHF303	€0.72	WASHER, plain	1	
66	GHF334	€1.32	WASHER, locking	1	
67	GCB11150	€9.12	FAN BELT, 3/8"	1	BN4, BN6
	GCB11125	€9.24	FAN BELT, 3/8"	1	BN7, BT7, BJ7, BJ8 to 29K-H10271
	GCB21100	€14.16	FAN BELT, 1/2"	1	
68	53K485	€2.52	STUD	4	BJ8 from 29K-H10272
69	GHF201	€0.84	NUT	4	
70	GHF332	€0.84	WASHER, locking	4	

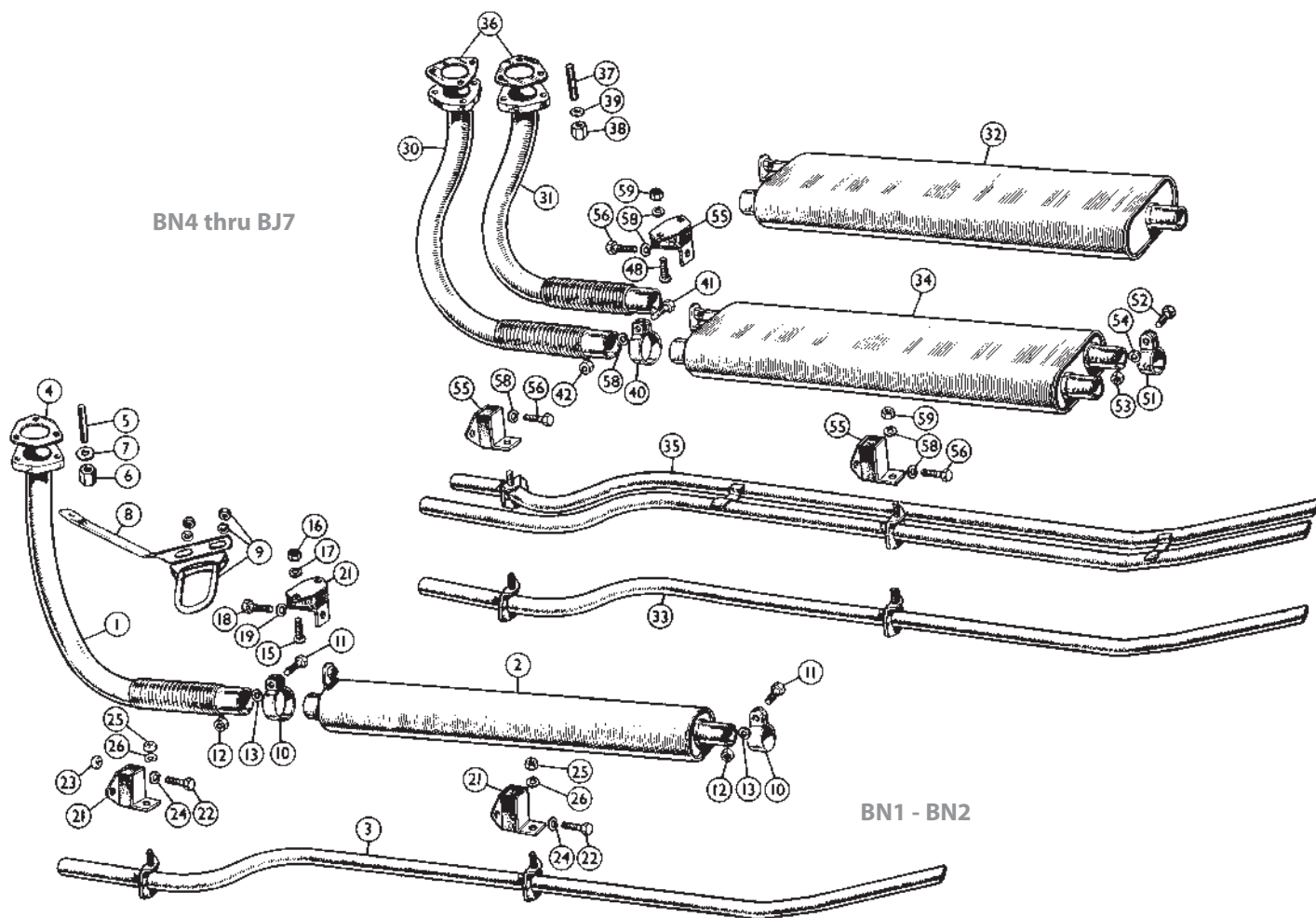

ill.	Part Number	Price €ea.	Description	Req.	Details
Exhaust Systems BN1 to BJ7					
	SC451	€405.60	EXHAUST SYSTEM, mild steel	1	BN1, BN2
	SC451SS	€364.80	EXHAUST SYSTEM, stainless steel	1	BN1, BN2
1	SC401	€131.88	FRONT PIPE, mild steel	1	BN1, BN2
	SC401SS	€114.24	FRONT PIPE, stainless steel	1	BN1, BN2
2	SC402	€186.84	SILENCER, mild steel	1	BN1, BN2
	SC402SS	€163.44	SILENCER, stainless steel	1	BN1, BN2
3	SC403	€114.24	TAIL PIPE, mild steel	1	BN1, BN2
	SC403SS	€123.36	TAIL PIPE, stainless steel	1	BN1, BN2
4	850-016	€433.20	EXHAUST SYSTEM, stainless steel	1	BN1, BN2
	GEK718	NA	GASKET, exhaust flange	1	BN1, BN2
5	328-795	€2.76	STUD	3	BN1, BN2
6	311-015	€3.48	NUT, brass	3	BN1, BN2
7	GHF301	€0.60	WASHER, plain	3	BN1, BN2
8	021-477	€28.08	BRACKET, front pipe	1	BN1, BN2
9	GEX9009	€1.80	CLAMP, pipe to bracket	1	BN1, BN2
10	725-035	€7.80	CLIP, for front pipe and tail pipe	2	BN1, BN2, OG type
	TT9932	NA	CLIP, for front pipe and tail pipe	2	BN1, BN2, replacement
11	GHF120	€0.72	BOLT, for clip	2	BN1, BN2
12	GHF201	€0.84	NUT	2	BN1, BN2
13	GHF332	€0.84	WASHER, locking	2	BN1, BN2
15	NA	NA	BOLT, mounting to chassis	2	BN1, BN2
16	GHF201	€0.84	NUT	2	BN1, BN2
17	GHF332	€0.84	WASHER, locking	2	BN1, BN2
18	GHF120	€0.72	BOLT, mounting to silencer	1	BN1, BN2
19	GHF332	€0.84	WASHER, locking	1	BN1, BN2
21	GEX7155	€6.48	MOUNTING, for tail pipe	3	BN1, BN2
22	GHF120	€0.72	BOLT, mounting to chassis	4	BN1, BN2
23	GHF201	€0.84	NUT	4	BN1, BN2
24	GHF332	€0.84	WASHER, locking	4	BN1, BN2
25	GHF201	€0.84	NUT	4	BN1, BN2
26	GHF332	€0.84	WASHER, locking	4	BN1, BN2
30	SC404	€97.44	FRONT PIPE, LH, mild steel	1	
	SC404SS	€88.20	FRONT PIPE, LH, stainless steel	1	BN4, BN6,
31	SC405	€96.48	FRONT PIPE, RH, mild steel	1	BN7, BT7, BJ7
	SC405SS	€88.20	FRONT PIPE, RH, stainless steel	1	
32	021-130	NA	SILENCER, mild steel	1	BN4 to C.E.48862
33	021-131	NA	TAIL PIPE ASSEMBLY, mild steel	1	
34	SC406	€285.60	SILENCER, mild steel	1	BN4 from C.E.48863,
	SC406SS	€261.60	SILENCER, stainless steel	1	BN6, BN7, BT7, BJ7
35	SC407	€129.36	TAIL PIPE ASSEMBLY, mild steel	1	

ill.	Part Number	Price €ea.	Description	Req.	Details
	SC407SS	€196.20	TAIL PIPE, stainless steel	1	
	610-145	€632.40	EXHAUST SYSTEM, stainless steel	1	
	SC452	€567.60	EXHAUST SYSTEM, mild steel	1	
	SC452SS	€612.00	EXHAUST SYSTEM, stainless steel	1	
	36	€7.44	GASKET exhaust flange	2	BN4, BN6, BN7,
	37	€1.92	STUD	6	BT7, BJ7
	38	€0.96	NUT, brass	6	
	39	€0.60	WASHER, plain	6	
	40	€6.48	CLIP, front pipe to silencer, original type	2	
	GEX9008	€1.44	CLIP, front pipe. w/hardware, replacement	2	
	41	€1.20	BOLT	2	
	SH605071	€0.84	NUT	2	
	42	€0.84	NUT	2	
	48	NA	SCREW, mounting to chassis	2	
	51	NA	CLIP, tail pipe, original type	1/2	
	GEX9005	€1.92	CLIP, tail pipe, replacement, inc. hardware	1/2	
	52	€0.84	BOLT	1/2	
	SH606071	€0.72	NUT	1/2	
	53	€0.72	WASHER, locking	1/2	
	GHF333	€6.48	MOUNTING, for tail pipe	3	
	GEX7155	€0.72	BOLT, mounting to chassis	5	
	GHF120	€0.84	WASHER, locking	11	
	GHF332	€0.84	NUT	4	
	GHF201	€0.84	NUT	4	

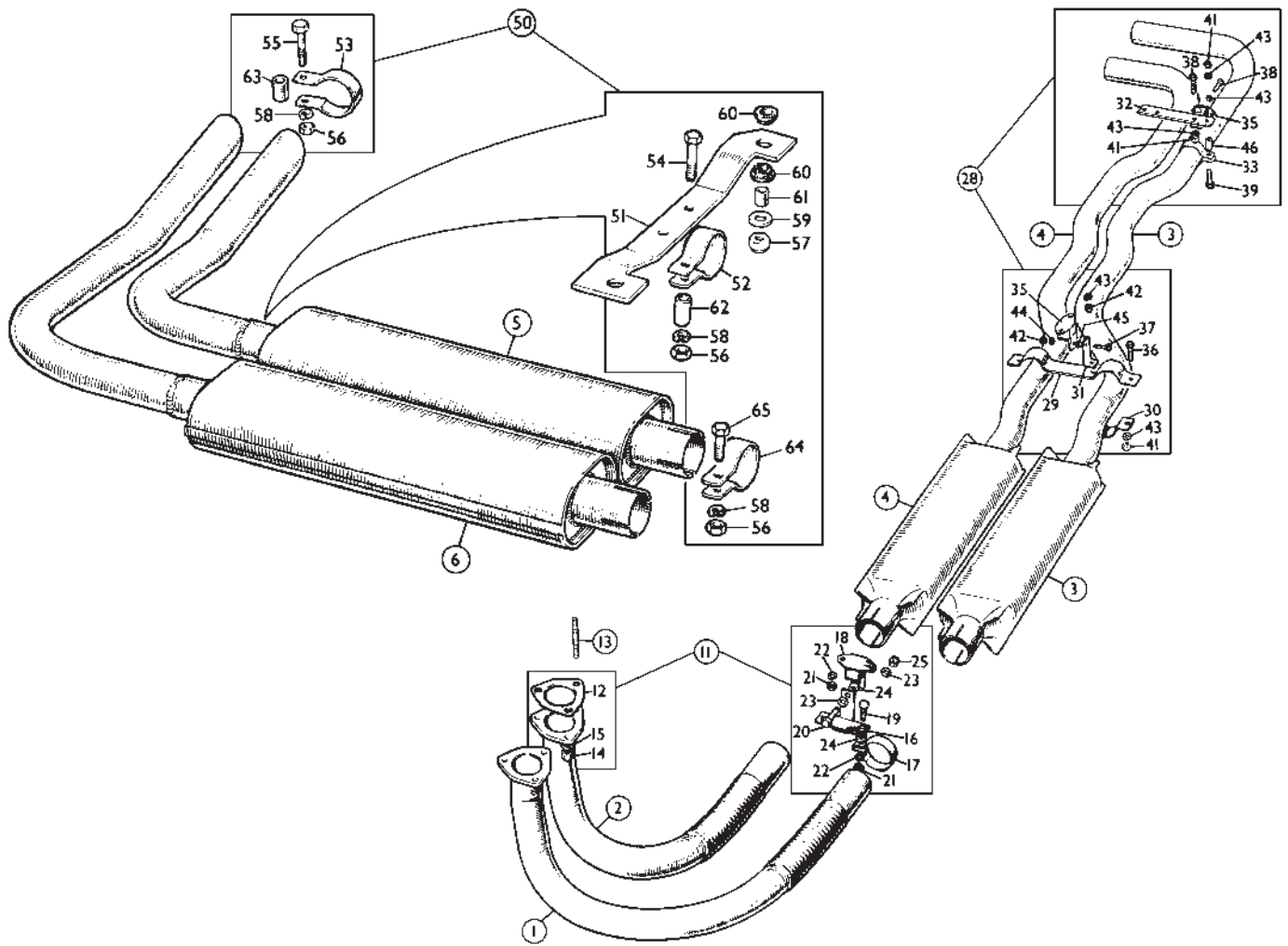

Part Number	Price €ea.	Description	Req.	Details
Exhaust Systems BJ8				
SC453	€694.80	EXHAUST SYSTEM, mild steel	1	
SC453SS	€978.00	EXHAUST SYSTEM, stainless steel	1	
1 SC408	€105.72	FRONT PIPE, LH, mild steel	1	
SC408SS	€86.88	FRONT PIPE, LH, stainless steel	1	
2 SC409	€102.96	FRONT PIPE, RH, mild steel	1	
SC409SS	€86.88	FRONT PIPE, RH, stainless steel	1	
3 SC411	€190.20	FRONT SILENCER & MID PIPE	1	LH, mild steel
SC411SS	€261.60	FRONT SILENCER & MID PIPE	1	LH, stainless steel
4 SC410	€190.20	FRONT SILENCER & MID PIPE	1	RH, mild steel
SC410SS	€261.60	FRONT SILENCER & MID PIPE	1	RH, stainless steel
5 SC412	€166.56	REAR SILENCER & TAIL PIPE	1	LH, mild steel
SC412SS	€146.16	REAR SILENCER & TAIL PIPE	1	LH, stainless steel
6 SC413	€166.56	REAR SILENCER & TAIL PIPE	1	RH, mild steel
SC413SS	€146.16	REAR SILENCER & TAIL PIPE	1	RH, stainless steel
Note: due to modern manufacturing techniques, silencer details may vary from those illustrated.				
850-001	€886.80	EXHAUST SYSTEM, stainless steel	1	
11 SC417	€55.08	EXHAUST FITTING KIT, front, stainless steel	1	
12 GEG706	€7.44	GASKET, exhaust flange	2	
13 FHS2513	€1.92	STUD	6	
14 GHF261	€0.96	NUT, brass	6	
15 GHF301	€0.60	WASHER, plain	6	
16	NA	BRACKET, exhaust mounting, front	1	
17	NA	CLIP, front pipe to silencer	2	
18 GEX7155	€6.48	MOUNTING, for front silencer	1	
19 SH605091	€1.80	BOLT, clip to bracket	2	
20 BH605111	€1.68	BOLT, bracket to mounting	1	
21 GHF201	€0.84	NUT	2	
22 GHF332	€0.84	WASHER, locking	2	
23	NA	WASHER, plain	4	
24 AHC442	€2.40	WASHER, insulating	3	
25 GHF222	€1.08	NUT, nyloc	2	
28 SC418	€71.04	EXHAUST FITTING KIT, centre	1	stainless steel
29	NA	CLIP, mid pipe, upper	1	
30	NA	CLIP, mid pipe, lower	2	
31	NA	BRACKET, clip mounting	2	
32	NA	STRAP, mounting mid pipe	1	
33	NA	CLIP, pipe to strap	2	
35 GEX7155	€6.48	MOUNTING, for mid pipes	4	
36 GHF103	€1.20	BOLT, clip	4	
37 BH605111	€1.68	BOLT, bracket to mounting, front	2	

Part Number	Price €ea.	Description	Req.	Details
38	NA	BOLT, bracket to mounting, rear	6	
39 BH605181	€1.92	BOLT	2	
41 GHF201	€0.84	NUT	8	
42 GHF222	€1.08	NUT, nyloc	2	
43 GHF332	€0.84	WASHER, locking	16	
44	NA	WASHER, plain	4	
45 AHC442	€2.40	WASHER, insulating	6	
46	NA	SPACER	2	
50 SC419	€69.48	EXHAUST FITTING KIT, rear, stainless steel	1	
51	NA	BRACKET, tail pipe mounting	1	
52	NA	CLIP, pipe to bracket	2	
53	NA	CLIP, tail pipe	2	
54	NA	BOLT	2	
55 BH605181	€1.92	BOLT	1	
56 GHF201	€0.84	NUT	5	
57 GHF222	€1.08	NUT, nyloc	2	
58 GHF332	€0.84	WASHER, locking	5	
59 PWZ205	€0.72	WASHER, plain	2	
60 GEX7151	€1.44	BUSH, rubber	4	
61	NA	SPACER	2	
62	NA	SPACER	2	
63	NA	SPACER	1	
64	NA	CLIP, mid pipe to rear silencer	2	

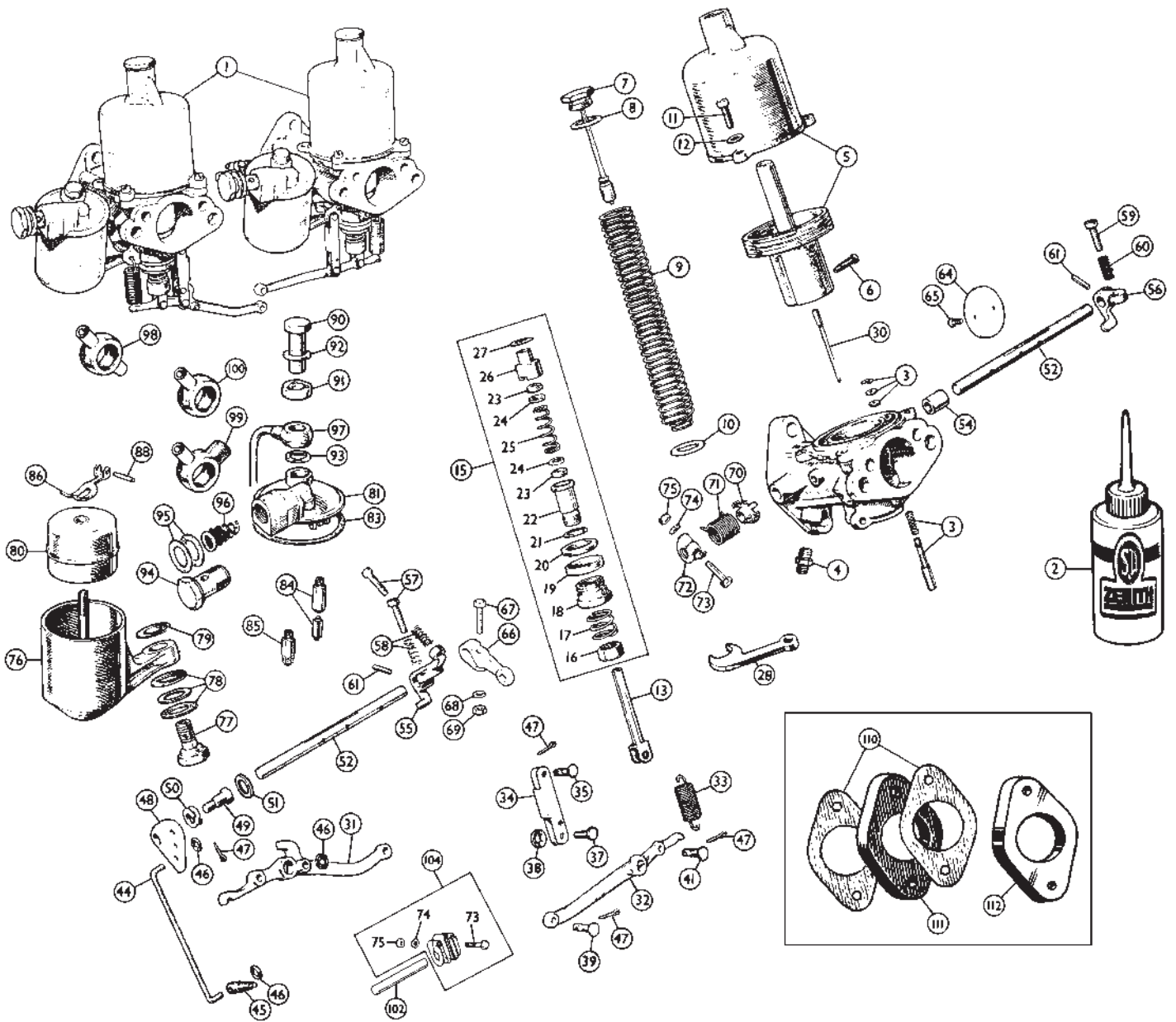

Ill.	Part Number	Price €ea.	Description	Req.	Details
H Type Carburettors BN1, BN2, early BN4					
1	370-688	€2,106.00	CARBURETTOR SET	1	BN1, BN2 (H4, AUC718)
	370-738	€2,311.20	CARBURETTOR SET	1	100M (H6, AUC739)
	370-698	€2,187.60	CARBURETTOR SET (fits early BN4 with 2-port head)	1	BN4 (H4, AUC815)
2	GGL819201	€8.52	DYNOLITE DAMPER OIL, 125 ml.	A/R	
	375-518†	€248.40	MASTER REBUILD KIT, for two carbs	1	BN1, BN2, BN4
	375-528†	€277.20	MASTER REBUILD KIT, for two carbs	1	100-M
	375-268	€253.20	REBUILD KIT, for two carbs	1	BN1, BN2, BN4
	370-538*	NA	REBUILD KIT, for two carbs	1	100-M
	CRK205	€122.04	OVERHAULT KIT, for one carb	2	BN1, BN2, BN4
	CRK210	€122.04	OVERHAULT KIT, for one carb	2	100-M
	698-000†	€7.44	GASKET KIT, for one carb	2	BN1, BN2, BN4
	AUE801A†	€24.48	GASKET KIT, for one carb	2	100-M
			† Master Rebuild Kits include items marked †.		
Note: Rebuild Kits include items marked *					
3	WX11105	€8.64	PIN & SPRING ASSEMBLY	2	
4	AUC5100	€13.80	UNION, vacuum advance, rear carburettor	1	
5	370-720	NA	CHAMBER & PISTON ASSEMBLY	2	BN1, BN2, BN4
	378-290	NA	CHAMBER & PISTON ASSEMBLY	2	100M
6	AUC2468	€12.24	SCREW, needle locking	2	
7	AUC8102HB	€48.84	CAP & DAMPER PISTON, brass	2	
	AUC8102A	€36.36	CAP & DAMPER PISTON, plastic	2	replacement
8	AUC2141†*	€0.84	WASHER, fibre	2	
9	AUC1167	€8.52	SPRING, piston return, yellow	2	BN1, BN2
	AUC4387	€14.76	SPRING, piston return, red	2	100M, BN4
10	AUC3071	€2.16	THRUST WASHER	2	BN4
11	JZX1394	€1.68	SCREW, chamber to body	6	
12	WL700101	€1.20	WASHER, shakeproof	6	
13	AUC8182†*	€17.64	JET	2	BN1, BN2, BN4
	AUC8183†*	€22.56	JET	2	100M
15	370-396	€74.52	JET BEARING KIT, "Superdry"	2	
	370-397	€9.24	SEAL SET, "Superdry" jet bearing kit only	2	
	WZX1593	€38.76	JET BEARING KIT (includes ill. nos.16 to 27 for one carb.)	2	
16	AUC2121	€5.40	NUT, adjusting	2	
17	AUC2114	€2.64	SPRING, adjusting nut	2	
18	AUC3232	€8.64	NUT, gland sealing	2	
19	AUC2117	€5.76	RING, sealing (aluminium)	2	
20	AUC2118†*	€2.04	RING, sealing (cork)	2	
21	AUC3233†*	€2.40	WASHER, bottom bearing (copper)	2	
22	AUC3231	€9.72	BEARING, bottom	2	
23	AUC2120†*	€2.04	WASHER, gland (cork)	4	
	RTC165A	€2.88	"O" RING (leak-free replacement for #23, not in kits)	4	
24	AUC2119†*	€3.24	WASHER, gland (brass)	4	
25	AUC1158	€5.04	SPRING, gland	2	
26	AUC3230	€13.44	BEARING, top	2	
27	AUC2122†*	€1.68	WASHER, top bearing (copper)	2	
28	AUD2693	€4.92	SPANNER, jet adjusting	1	
30	374-300	NA	NEEDLE, jet, rich (QA)	2	BN1, BN2
	AUD1284	€27.12	NEEDLE, jet, std. (QW)	2	
	AUD1050	NA	NEEDLE, jet, lean (AT)	2	
	AUD1276	€27.12	NEEDLE, jet, rich (OA6)	2	100M
	021-076	NA	NEEDLE, jet, std. (OA7)	2	
	AUD1278	€27.12	NEEDLE, jet, lean (OA8)	2	
	AUD1003	€27.12	NEEDLE, jet, rich (4)	2	BN4
	854-166	NA	NEEDLE, jet, std. (AJ)	2	
	AUD1267	€27.12	NEEDLE, jet, lean (M1)	2	
31	370-445	€98.76	LEVER, jet, front carburettor	1	
32	370-455	NA	LEVER, jet, rear carburettor	1	BN1, BN2, 100M
		NA	LEVER, jet, rear carburettor	1	BN4
33	AUC4667	€7.92	SPRING, jet lever return	2	
34	AUC4819	€38.88	LINK, jet lever	2	BN1, BN2, 100M
	AUC4819	€38.88	LINK, jet lever, front	1	BN4
	AUC3419	€38.88	LINK, jet lever, rear	1	
35	AUC2381†	€2.88	PIN, link to body	2	
37	AUC5009†	€3.48	PIN, link to lever (use #35 with #47)	2	
38	AUC5004†	€1.44	WASHER, starlock	2	BN1, BN2, 100M
39	AUC2381†	€2.88	PIN, link to lever	2	BN4
41	AUC2108†	€4.92	PIN, lever to jet	2	BN1, BN2, 100M
	AUC2381†	€2.88	PIN, lever to jet	2	BN4
44	AUC4732	€15.12	LINK, tension	1	BN1, BN2, BN4
	AUC3525	€19.20	LINK, tension	1	100M
45	AUC5011	€11.40	PIN, swivel	1	BN1, BN2, 100M
		NA	PIN, swivel	1	BN4
46	AUC5002†	€1.80	WASHER, starlock	3	BN1, BN2, 100M
47	GHF500†*	€1.08	SPLIT PIN	A/R	
48	AUC4730	€50.88	CAM PLATE	1	
49	AUC3471	€7.32	BOLT, pivot	1	
50	AJD7722	€0.84	WASHER, thackery	1	
51	AUC4848	€4.08	WASHER, aluminium	1	BN4
52	AUC3242†	€32.16	SHAFT, throttle, std.	2	BN1, BN2, BN4
	AUC3242RP	€32.16	SHAFT, throttle, oversize	2	
	AUC4284†	€28.44	SHAFT, throttle, std.	2	100M
	AUC4284RP	€28.92	SHAFT, throttle, oversize	2	
54	AUD3080†	€5.88	BUSH, throttle shaft	4	
55	AUC4713	€78.00	LEVER, throttle stop, front carburettor	1	
		NA	LEVER, throttle stop, rear carburettor	1	100M, BN4
57	AUC3464	€1.56	SCREW, stop adjusting, 4BA	2	BN1, BN2, BN4
58	AUC2451	€1.56	SPRING	1/2	
59	AUC8483	NA	SCREW, stop adjusting, 4BA	1	BN1, BN2, 100M
	AUC3464	€1.56	SCREW, stop adjusting, 4BA	1	BN4

Ill.	Part Number	Price €ea.	Description	Req.	Details
60	AUC2451	€1.56	SPRING	1	
61	AUC2106†	€1.92	PIN, tapered	1/2	
64	WZX1323†	€19.32	DISC, throttle	2	BN1, BN2, BN4
	WZX1321†	€18.00	DISC, throttle	2	100M
65	AUC1358	€1.80	SCREW	4	
66		NA	LEVER, throttle	1	
67	AUC2694	€1.56	BOLT, lever	1	
68	WL700101	€1.20	WASHER, locking	1	
69	AJD8012Z	€0.72	NUT	1	
70	AUC4770	€25.56	PLATE, return spring anchor	2	
71	AUC4781	€10.08	SPRING, return	2	
72	AUC4771	€17.16	CLIP, for return spring	2	
73	AUC2669	€2.04	BOLT, for clip	6	
74	PWZ102	€1.08	WASHER, plain	6	
75	AJD8014Z	€0.72	NUT	6	
76	AUC3496	NA	CHAMBER, float	2	BN1, BN2, 100M
	AUE561	€304.80	CHAMBER, float	2	BN4
77	AUC1541	€16.68	BOLT, chamber to body	2	
78	AUE6†*	€4.20	WASHER KIT, 2 fiber and 1 steel	2	
79	AUC2130†*	€1.56	WASHER, fibre	2	
80	WZX1303	€27.00	FLOAT, orig. type, brass	2	
	WZX1303X	€23.16	FLOAT, Nitrophyll replacement	2	
81	AUE478	€126.84	LID, float chamber, front & rear	2	BN1, BN2, 100M
	AUE479	€126.84	LID, float chamber, front	1	BN4
	AUE478	€126.84	LID, float chamber, rear	1	
Note: Lids include nos. 83, 84, 87, 88. Only replacement levers 371-030 can be used with these lids.					
83	AUC1147A†*	€1.56	GASKET, float chamber lid	2	
84	WZX1101A†	€16.56	NEEDLE & VALVE SEAT	2	
	WZX1102A	€21.36	NEEDLE & VALVE SEAT, aftermarket	2	
85	GAC9201X	€13.44	GROSE-JET (superior replacement for needle & seat)	2	
86	AUC1980	€13.32	LEVER, hinged	2	for original lids
	AUD2285	€9.24	LEVER, hinged	2	for replacement lids
88	AUC1152†*	€1.20	PIN	2	
90	AUC1163	€14.76	CAP NUT	2	BN1, BN2, BN4
	AUC1867X	€10.08	CAP NUT	2	100M
91	AUC1245	NA	COVER CAP	2	BN1, BN2, BN4
92	AUC1557†*	€0.96	WASHER, aluminium	2	
93	AUC1928†*	€1.56	WASHER, fibre	4	100M
94	AUC2698	€7.56	BOLT, banjo	2	
95	AUC2141†*	€0.84	WASHER, fiber	4	
96	AUC2139	€13.80	FILTER & SPRING	2	
97	AUC1866	€23.40	VENT & DRAIN PIPE to cold air box	2	100M
		NA	BANJO UNION, double, front	1	BN1, BN2
		NA	BANJO UNION, double, front	1	BN4
100	AUC1833	€15.60	BANJO UNION, single, rear	1	
102	AUC2397	NA	ROD, throttle connecting	1	BN1, BN2
	370-845	€6.12	ROD, throttle connecting	1	100M
		NA	ROD, throttle connecting	1	BN4
104	AUE75	€25.56	COUPLING LINK	2	
110	1G2624†*	€1.56	GASKET, manifold to carburettor	2	BN1 to C.E.139915
	1G2624†*	€1.56	GASKET, manifold to carburettor	4	BN1 from C.E.139915, BN2
	112867†*	€1.20	GASKET, manifold to carburettor	2	100M
	AEH551†*	€1.80	GASKET, manifold to carburettor	2	BN4
111	AHH5713	€8.76	SPACER	2	BN1, BN2
112		NA	SPACER, aluminium	2	BN4
113	386-385	€322.80	REAMER, throttle shaft bush	1	
† Master Rebuild Kits include items marked †.					
*Rebuild Kits include items marked *.					

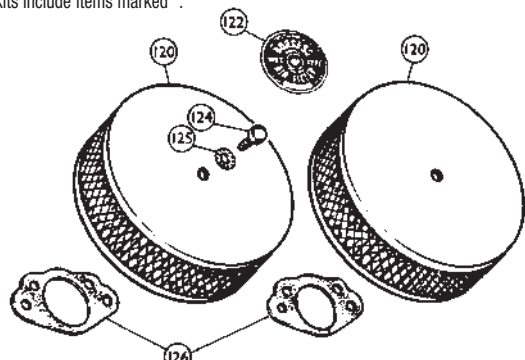

120	372-095	€98.28	AIR FILTER, with vent tube, stock filter	1	BN1, BN2, BN4 (Burgess filters)
	372-085	€215.04	AIR FILTER, no vent tube, stock filter	1	
	AHH5442	€14.40	FILTER ELEMENT, Coopers type	2	
	372-095	€98.28	AIR FILTER, with vent tube	1	
	372-086	€200.40	AIR FILTER, no vent tube, K&N filter	1	
	223-006	€61.20	FILTER ELEMENT, K&N	2	
122	372-195	€6.48	LABEL, "Burgess"	2	(incl. with air filters above)
124		NA	BOLT	4	BN1, BN2
	SH605071	€1.20	BOLT	4	BN4
125	GHF301	€0.60	WASHER, plain	4	
126	12G2125	€0.96	GASKET, air filter to carb	2	BN1, BN2, BN4
	112892	€2.16	GASKET, air filter to carb	2	100M

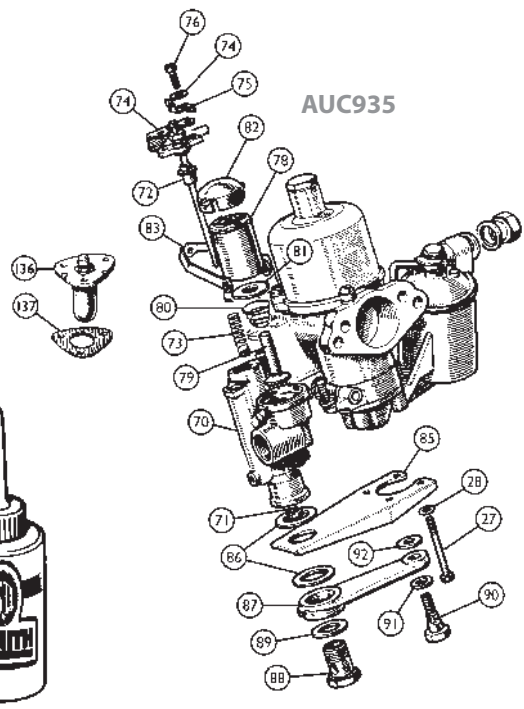
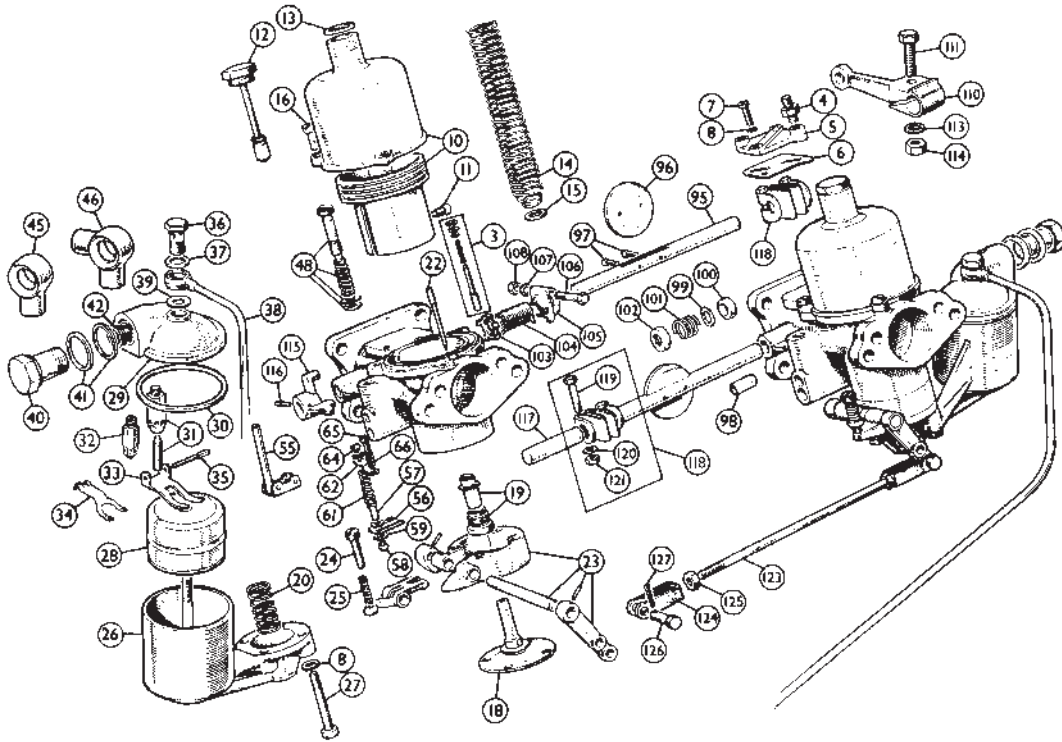

Ill.	Part Number	Price €ea.	Description	Req.	Details
Twin HD6 Carburettors late BN4 to BN7/BT7					
	370-618	€2,792.40	CARBURETTOR SET (AUC866)	1	BN4, BN6
	370-628	€2,792.40	CARBURETTOR SET (AUC914)	1	BN7 & BT7
	370-638	€3,470.40	CARBURETTOR SET (AUC935)	1	BN7 & BT7
	370-648	€2,792.40	CARBURETTOR SET (AUC963)	1	BN7 & BT7
			A BN 4 with 6-port head, all BN6		
			B BN7 & BT7 thru (e)29D-H2863, and 6395 thru 18655		
			C BN7 & BT7 from (e) 29D-H2864 thru 6394 (auto choke)		
			D BN7 & BT7 from (e)29D-H18656 thru 26212		
2	GGL19201	€8.52	DYNOLITE DAMPER OIL, 125 ml.	A/R	
	375-588†	€289.20	MASTER REBUILD KIT, for two carbs	1	
	375-288	€197.28	REBUILD KIT, for two carbs	1	
	698-078†*	€15.12	GASKET KIT, for two carbs	1	
3	WZX1110	€9.72	PIN & SPRING ASSEMBLY	2	
4	AUC4490	€14.28	UNION, vacuum advance, rear carburettor	1	
5	373-111	€52.20	ADAPTOR, for union	1	
6	378-140†*	€1.80	GASKET, for adaptor	1	
†*Note: Master Rebuild Kits include items marked †					
Rebuild Kits include items marked *					
7	JZX1394	€1.68	SCREW, for adaptor	2	
8	WL700101	€1.20	WASHER, shakeproof	A/R	
10		NA	CHAMBER & PISTON ASSEMBLY	2	AUC866, AUC914 thru (e)29D-H2863
	AUD9187	NA	CHAMBER & PISTON ASSEMBLY	2	AUC914 from 29D-H2864, AUC935, AUC963
11	AUC2057	€4.20	SCREW, needle locking	2	
12	AUC8102HB	€48.84	CAP & DAMPER PISTON, brass	2	AUC866, AUC914 thru (e) 29D-H2863
	AUC8102A	€36.36	CAP & DAMPER PISTON, plastic	2	AUC914 from 29D-H2864
	AUC8103HB	€48.84	CAP & DAMPER PISTON, brass	2	AUC935, AUC963
	AUC8103A	€36.36	CAP & DAMPER PISTON, plastic	2	
13	AUC2141†*	€0.84	WASHER, fiber	2	
14	AUC1167	€8.52	SPRING, piston return, yellow	2	BN4, BN6
	AUC1170	€13.44	SPRING, piston return, green	2	BN7, BT7
15	AUC3071	€2.16	THRUST WASHER	2	
16	JZX1394	€1.68	SCREW, chamber to body	6	
18	AUC8155†*	€53.28	JET ASSEMBLY, 0.100	2	
19	WZX1211	€8.64	JET BEARING KIT	2	
20	AUC2006	€2.52	SPRING, jet return	2	
22	021-084	€16.68	NEEDLE, jet, rich (RD)	2	
	AUD1112	€27.12	NEEDLE, jet, std. (CV)	2	
	AUD1332	€27.12	NEEDLE, jet, lean (SQ)	2	
23	373-112	€312.00	HOUSING ASSEMBLY, jet, front	1	
	373-113	€342.00	HOUSING ASSEMBLY, jet, rear	1	
24	AUC8483	NA	SCREW, jet adjusting	2	
25	AUC2451	€1.56	SPRING	2	
26	AUC2067	NA	CHAMBER, float, front	1	AUC866, AUC914, AUC963
	AUC2062	NA	CHAMBER, float, rear	1	BN7 & BT7 AUC935
	373-130	NA	CHAMBER, float, rear	1	
27	AUC2110	€6.12	BOLT, chamber to body	8	
28	WZX1303	€27.00	FLOAT, orig. type, brass	2	
	WZX1303X	€23.16	FLOAT, Nitrophyl replacement	2	
29	AUE479	€126.84	LID, float chamber, front	1	inc. items no. 30, 31, 34, 35
	AUE478	€126.84	LID, float chamber, rear	1	
30	AUC1147A†*	€1.56	GASKET, float chamber lid	2	
31	WZX1101A†	€16.56	NEEDLE & VALVE SEAT, Viton tip	2	
	WZX1102A	€21.36	NEEDLE & VALVE SEAT, Viton tip	2	aftermarket
32	GAC9201X	€13.44	GROSE-JET, superior replacement	2	
33	AUC1980	€13.32	LEVER, hinged	2	for original lids
34	AUD2285	€9.24	LEVER, hinged	2	for replacement lids
35	AUC1152†	€1.20	PIN	2	
36	AUC1867X	€10.08	CAP NUT, standard length	2	
	370-151	NA	CAP NUT, extended length	2	
			(Catches available threads on a broken centre stud)		
37	AUC1557†*	€0.96	WASHER, aluminium	2	
38	AUC1866	€23.40	BANJO VENT & DRAIN PIPE	2	cut pipe to fit
39	AUC1928†*	€1.56	WASHER, fiber	2	
40	AUC2698	€7.56	BOLT, banjo	2	
41	AUC2141†*	€0.84	WASHER, fibre	4	
42	AUC2139	€13.80	FILTER & SPRING	2	
45	370-125	€44.52	BANJO UNION, rear, single	1	BN4, BN6, BN7, BT7
46		NA	BANJO UNION, front, double	1	BN4 to C.E.48862
		NA	BANJO UNION, front, double	1	BN4 from C.E.48863, BN6, BN7, BT7
48	WZX992	€20.88	SLOW RUNNING VALVE KIT	2	
	031-996	€17.52	SCREW, slow running	2	
	031-997	€3.72	SPRING	2	
	AUC2030†*	€2.04	WASHER, cupped	2	
	AUC2029†*	€2.88	WASHER, rubber	2	
55		NA	CAM SHOE & ROD ASSEMBLY	2	AUC963
56		NA	SHOE, for cam	2	
57		NA	ROD, for shoe	2	AUC866, AUC914
58	373-114	€1.80	SCREW, rod to shoe	2	
59		NA	WASHER, locking	2	AUC866
61	AUC2020	NA	SPRING, for rod	2	
62	373-116	€26.64	PLATE, top	2	
64	373-114	€1.80	SCREW, plate retaining	2	AUC914, AUC963
65	AUC3464	€1.56	SCREW, stop adjusting	2	
66	AUC2451	€1.56	SPRING	2	

Ill.	Part Number	Price €ea.	Description	Req.	Details
	70		NA BODY, thermo carb	1	
	71	AUC4759	NA JET, accelerator	1	
	72	373-160	€76.20 NEEDLE ASSEMBLY	1	
	73	373-170	€2.88 SPRING, blue, for needle	1	
	74		NA SHIELD, dust	1	
	75		NA FINGER, spring	1	
	76		NA SCREW, fixing	2	
	78	AUD9490	€171.84 SOLENOID ASSEMBLY	1	
	79		NA PLUNGER & VALVE ASSEMBLY	1	
	80		NA SPRING, conical valve	1	AUC935
	81		NA PLATE, spring locating	1	
	82		NA END CAP, moulded	1	
	83		NA STRAP, securing	1	
	84		NA SCREW, clamping	1	
	85	373-117	€41.52 BRACKET, thermo body	1	
	86	370-165	€1.92 WASHER, fibre	2	
	87	373-180	€70.92 ARM	1	
	88	AUC2698	€7.56 BOLT, pipe casting to thermo body	1	
	89	AUC2141†*	€0.84 WASHER, fibre	1	
	90	AUC2086	€14.88 BOLT, pipe casting to float chamber	1	
	91	AUC1557†*	€0.96 WASHER, aluminium	1	
	92	370-131	NA WASHER, fibre	1	
	95	AUC4284†	€28.44 SHAFT, throttle, std.	2	
		AUC4284RP	€28.92 SHAFT, throttle, oversize	2	
	96	WZX1321†	€18.00 DISC, throttle	2	
	97	AUC1358†	€1.80 SCREW	4	
	98	AUD3080†	€5.88 BUSH, throttle shaft	4	
		WZX1262	€10.08 SUNDRIES KIT, throttle shaft	2	(for 1 carb.)
	99		NA WASHER	4	
	100	†*	NA WASHER, cork	4	
	101		NA SPRING	4	
	102		NA CAP	4	
	103		NA PLATE, return spring, anchor	2	
	104	AUC4781	€10.08 SPRING, return	2	
	105	AUC4771	€17.16 CLIP	2	
	106	AUC2669	€2.04 BOLT	2	
	107	PWZ102	€1.08 WASHER, plain	2	
	108	AJD8014Z	€0.72 NUT	2	
	110	373-118	€24.60 LEVER, throttle, rear carb. (cast brass)	1	BN4, BN6, BN7 & BT7 to 29D-H2863
		373-119	€29.76 LEVER, throttle, rear carb. (stamped steel)	1	BN7 & BT7 29D-H2864 to 29D-H26212
	111	AUC2694	€1.56 BOLT	1	
	113	AUC8396	€1.08 WASHER, plain	1	
	114	AJD8012Z	€0.72 NUT	1	
	115	373-121	€25.68 STOP, throttle	2	AUC866, AUC914, AUC963
		373-122	€27.12 STOP, throttle, rear carb.	1	AUC935
	116	AUC2106†	€1.92 PIN, tapered	A/R	
	117	373-123	€10.68 ROD, throttle connecting	1	
	118	AUE75	€25.56 COUPLING ASSEMBLY	2	
	119	AUC2669	€2.04 BOLT	4	
	120	PWZ102	€1.08 WASHER, plain	4	
	121	AJD8014Z	€0.72 NUT	4	
	123	373-220	€50.88 ROD, connecting jet levers	1	
	124	AUC2256	€28.44 FORK	2	
	125	AJD8012Z	€0.72 NUT	2	AUC866, AUC914, AUC963
	126	AUC2108	€4.92 PIN	2	
	127	GHF500	€1.08 SPLIT PIN	2	
	136	AUD3936	€116.28 SWITCH, thermal	1	AUC935
	137	236022A	€3.72 GASKET	1	
	142	112866	€5.76 SPACER	2	
	143	112867†*	€1.20 GASKET, heat shield to carburettor	2	
	144	11B621	€54.72 AIR FILTER, front	1	
	145	AHB9909	€54.72 AIR FILTER, rear, with breather fitting	1	
	146	215-691	€2.64 DECAL, air filter, Coopers	2	
	147	SH605071	€1.20 BOLT	4	
	148	GHF301	€0.60 WASHER, plain	4	
	149	GHF332	€0.84 WASHER, locking	4	
	150	112892†*	€2.16 GASKET, air filter to carb.	2	

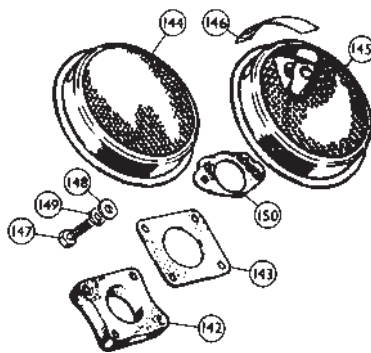

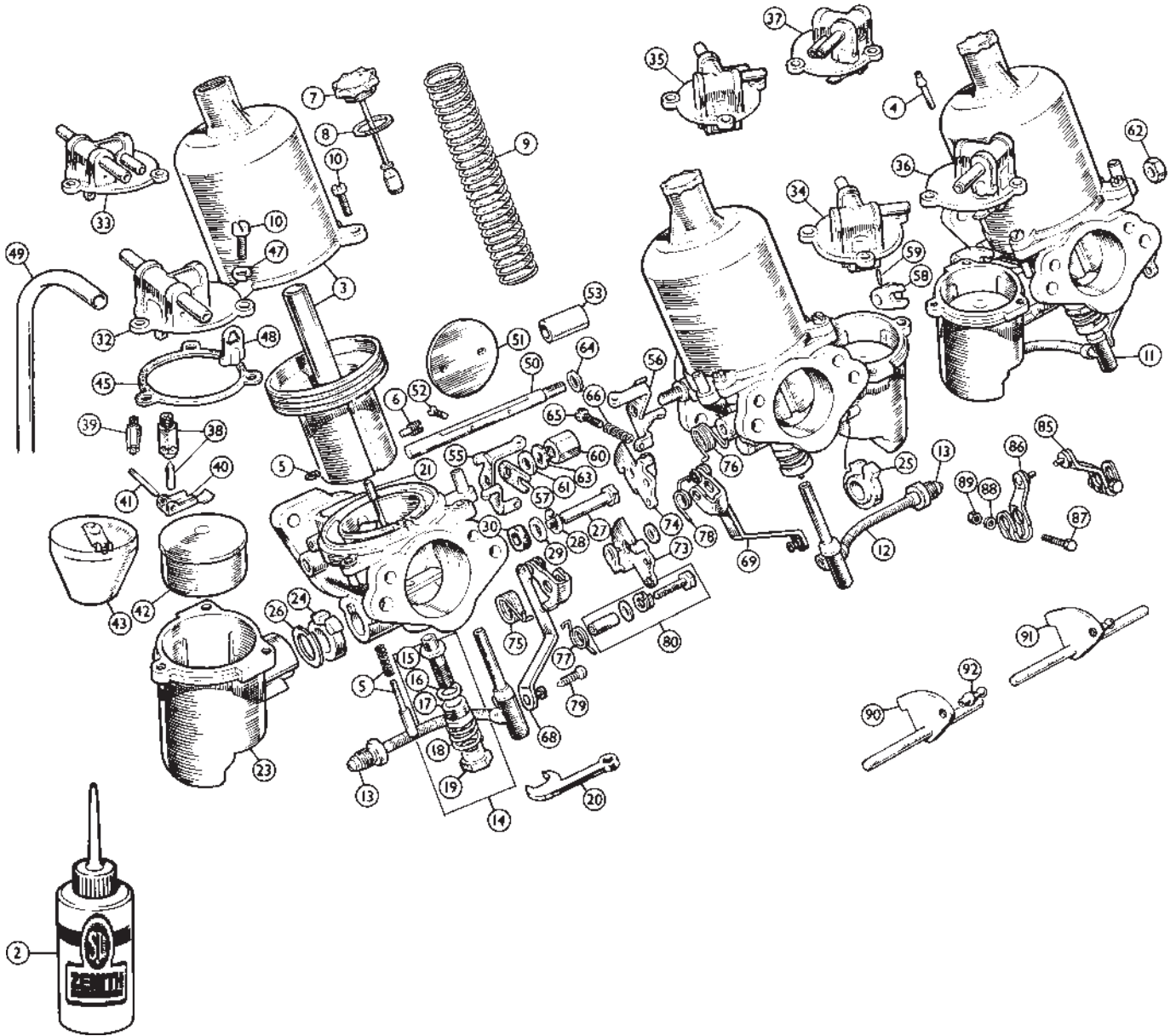

ill.	Part Number	Price €ea.	Description	Req.	Details
Triple HS4 Type Carburettors BN7/BT7					
	AUD18S	€2,038.80	CARBURETTOR SET (AUD18	1	no. 90, 91 not included
2	GGL819201	€8.52	DYNOLITE DAMPER OIL, 125 ml.	A/R	
	375-568†	€260.40	MASTER REBUILD KIT, for 3 carbs	1	
	375-308	€254.40	REBUILD KIT, for three carbs.	1	
	698-058†	€8.64	GASKET KIT, for three carbs	1	

Master rebuild kits include items marked †

Rebuild kits include items marked *

3	NA		CHAMBER & PISTON ASSEMBLY	3	
4	NA		TUBE, vacuum advance	1	
5	WZX1105	€8.64	PIN & SPRING ASSEMBLY	3	
6	AUC2057	€4.20	SCREW, needle locking	3	
7	AUC8114A	€36.36	CAP & DAMPER ASSEMBLY, plastic	3	
8	AUC2141†*	€0.84	WASHER, fibre	3	
9	AUC4387	€14.76	SPRING, piston return, red	3	
10	JZX1394	€1.68	SCREW	18	
11	AUD9098A†*	€40.80	JET ASSEMBLY, front & rear carbs.	2	
12	AUD9102†*	€43.20	JET ASSEMBLY, centre carb.	1	
13	AUD2194	€2.16	SEAL to float bowls	3	
14	WZX1341	€14.52	JET BEARING ASSEMBLY	3	incl. one ea. ill. nos. 15-19
15	NA		BEARING, for jet	3	
16	AUC8478†*	€2.16	WASHER	3	
17	AUC2002	€8.16	SCREW, jet locking	3	
18	AUC2114	€2.64	SPRING, jet return	3	
19	AUC8461	€4.08	SCREW, jet adjusting	3	
20	AUD2693	€4.92	SPANNER, jet adjusting, 5/16" W	3	original carbs
	JZX1187	€9.12	SPANNER, jet adjusting, 17mm	1	new replacement carbs
21	374-050	€27.12	NEEDLE, jet, rich (DK)	3	
	854-183	€27.12	NEEDLE, jet, std. (DJ)	3	
	374-340	€27.12	NEEDLE, jet, lean (DH)	3	
23	AUC1310	€116.28	CHAMBER, float	3	
24	372-660	€6.00	ADAPTOR, front & rear carbs.	2	to 29E-H928
	AUD2178	€15.84	ADAPTOR, front & rear carbs.	2	from 29E-H929
	AUD2063	NA	ADAPTOR, centre carb.	1	to 29E-H928
	AUD2179	€15.84	ADAPTOR, centre carb.	1	from 29E-H929
26	AUC1329	€4.20	WASHER, adaptor	3	
27	AUD3017	€5.64	BOLT, chamber to body	3	
28	GHF332	€0.84	WASHER, locking	3	to 29E-H928
29	AUC1317	€1.44	WASHER, plain	3	
30	AUC1318	€5.40	WASHER, rubber	3	from 29E-H929
32	AUE267	NA	LID & FLOAT ASSY, front	1	to 29E-H1091
33	372-710	NA	LID, front	1	from 29E-H1092
34	AUE268	€103.80	LID, centre	1	to 29E-H1091
35	NA		LID, centre	1	from 29E-H1092
36	AUE271	€117.00	LID, rear	1	to 29E-H1091
37	AUE274	€117.00	LID & FLOAT ASSY, rear	1	from 29E-H1092
38	WZX1101A†	€16.56	NEEDLE & VALVE SEAT, Viton tip	3	
	373-626	€18.48	NEEDLE & VALVE SEAT, Viton tip	3	aftermarket
39	GAC9201X	€13.44	GROSE-JET, superior replacement	3	
40	370-155	NA	LEVER, hinged	3	to 29E-H2994
41	AUC1152	€1.20	PIN	3	
42	WZX1301	€18.36	FLOAT, brass	3	to 29E-H2994
43	WZX1300	€21.24	FLOAT, plastic, w/ metal hinge tab	3	from 29E-H2995
	378-471	€0.72	SHIM, .015"	A/R	

Note: Older SU replacement floats have moulded bosses for the pin. To use these and obtain the correct 1/16"-3/16" gap between the float and lid, a shim may be required under the needle & seat assembly.

45	AUC8459A	€2.64	GASKET, float chamber lid	3	
47	GHF331	€0.84	WASHER, locking	9	
48	NA		PLATE, baffle, for lid	3	
49	NA		OVERFLOW PIPE, front carb.	1	from 29E-H1092
	NA		OVERFLOW PIPE, centre & rear carbs.	2	
50	WZX1177†	€25.32	SHAFT, throttle, std.	3	
	WZX1177RP	€28.92	SHAFT, throttle, oversize	3	
51	WZX1323†	€19.32	DISC, throttle	3	
52	AUC1358†	€1.80	SCREW	6	
53	AUD3080†	€5.88	BUSH, throttle shaft	6	
55	372-780	NA	LEVER, throttle return, front & rear carbs.	2	
56	NA		LEVER, throttle return, centre carb.	1	
57	JZX1328	€17.88	LEVER, lost motion, front carb.	1	
58	372-850	NA	LEVER, lost motion, centre & rear carbs.	2	
59	AUC2106	€1.92	PIN, tapered	2	
60	AUC1424	€4.44	NUT, for lever, front & centre carbs.	2	
61	PWZ203	€0.96	WASHER, plain	2	
62	AJD8014Z	€0.72	NUT, for lever, rear carb.	1	
63	AUD3323	€1.56	WASHER, tab	3	
64	AUC2625	€1.32	WASHER, brass	3	
65	AUC8483	NA	SCREW, throttle stop	6	
66	AUC2451	€1.56	SPRING	6	
68	LZX1274	€27.48	PICK-UP LEVER & LINK ASSEMBLY, front & rear carbs.	2	(replacement)
69	LZX1275	€27.48	PICK-UP LEVER & LINK ASSEMBLY, centre carb.	1	(replacement)
	AUC5002	€1.80	WASHER, starlock	3	
73	372-900	NA	LEVER, cam	2	front & rear carbs.
74	AUD3346	€17.04	LEVER, cam	1	centre carb.
75	WZX1335	€8.64	SPRING, for pick-up lever	2	front & rear carbs.
76	WZX1336	NA	SPRING, for pick-up lever	1	centre carb.
77	AUD2431	€3.48	SPRING, for cam lever	2	front & rear carbs.
78	AUD2049	€1.80	SPRING, for cam lever	1	centre carb.
79	AB606051	€0.84	SCREW, self-tapping	3	
80	WZX1331	€15.48	PIVOT BOLT ASSEMBLY	3	
85	AUE587	€4.44	LEVER, lost motion pick-up	2	front & rear carbs.

ill.	Part Number	Price €ea.	Description	Req.	Details
86	AUE586	€4.44	LEVER, lost motion pick-up	1	centre carb.
87	AUC2694	€1.56	BOLT	3	
88	AUC8396	€1.08	WASHER, plain	3	
89	AJD8012Z	€0.72	NUT	3	
90	NA		SHAFT, carb. coupling, front	1	
91	NA		SHAFT, carb. coupling, rear	1	
92	NA		BALL END	2	

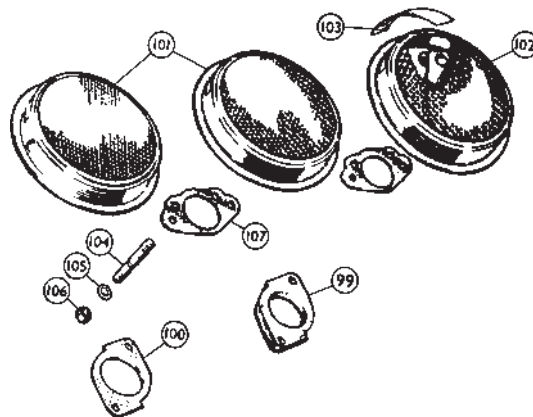

99	696-050	€28.56	SPACER (1/4" thick)	3	from 29E-H929
100	AEC2083†*	€1.08	GASKET, carb. mounting	6	to 29E-H928
	AEC2083	€1.08	GASKET, heat shield to manifold	3	from 29E-H929
101	AHB9023	€54.72	AIR FILTER, front & centre	2	
102	AHB9024	€54.72	AIR FILTER, rear, with breather fitting	1	
103	215-691	€2.64	DECAL, air filters, Coopers	3	
104	TE605105	€3.24	STUD, air filter to carb.	6	
105	GHF301	€0.60	WASHER, plain	6	
106	GHF201	€0.84	NUT	6	
107	12G2125†*	€0.96	GASKET, air filter to carb.	3	

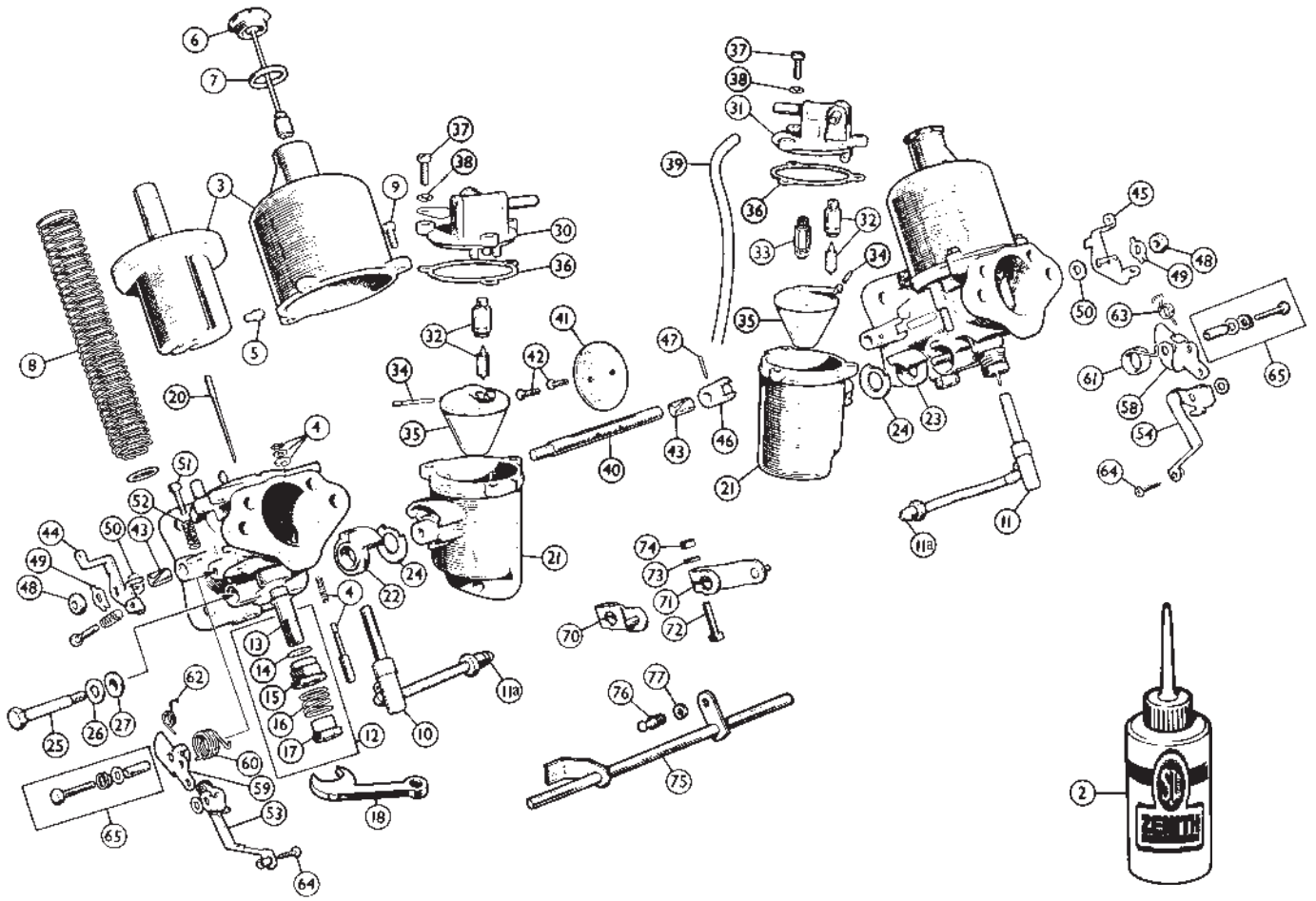

ill.	Part Number	Price €ea.	Description	Req.	Details
HS6 Type Carburetors BJ7					
	370-888	€1,474.80	CARBURETTOR SET	1	(AUC981)
2	GGL819201	€8.52	DYNOLITE DAMPER OIL, 125 ml.	A/R	
	GAC6104X†	€297.60	MASTER REBUILD KIT, for two carbs.	1	
	375-318	€104.40	REBUILD KIT, for two carbs.	1	
	AUE812A†*	€9.72	GASKET KIT, for one carb.	2	
Master rebuild kits include items marked †					
Rebuild kits include items marked *					
3	AUD9187	NA	CHAMBER & PISTON ASSEMBLY	2	
4	WZX1112	€9.72	PIN & SPRING ASSEMBLY	2	
5	AUC2057	€4.20	SCREW, needle locking	2	
6	AUC8103HB	€48.84	CAP & DAMPER ASSEMBLY, brass	2	
	AUC8103A	€36.36	CAP & DAMPER ASSEMBLY, plastic	2	
7	AUC2141†*	€0.84	WASHER, fibre	2	
8	AUC1170	€13.44	SPRING, piston return, green	2	
9	JZX1394	€1.68	SCREW, chamber to body	6	
10	AUD9149†*	€27.60	JET ASSEMBLY, front carb	1	
11	AUD9148A†*	€27.60	JET ASSEMBLY, rear carb.	1	
11a	AUD2194	€2.16	SEAL to float bowls	2	
12	WZX1341	€14.52	JET BEARING ASSEMBLY	2	(incl. one ea. ill. no. 13-17)
13	WZX1341	€14.52	BEARING, for jet	2	
14	AUC8478†*	€2.16	WASHER	2	
15	AUC2002	€8.16	NUT, jet locking	2	
16	AUC2114	€2.64	SPRING, jet adjuster	2	
17	AUC8461	€4.08	NUT, jet adjusting	2	
18	AUD2693	€4.92	SPANNER, jet adjusting, 5/16" W	1	original carbs
	JZX1187	€9.12	SPANNER, jet adjusting, 17mm	1	new replacement carbs.
20	021-084	€16.68	NEEDLE, jet, rich (RD)	2	
	AUD1063	€27.12	NEEDLE, jet, std. (BC)	2	
	AUD1469	€27.12	NEEDLE, jet, lean (TZ)	2	
21	AUC1310	€116.28	CHAMBER, float	2	
22	AUD2179	€15.84	ADAPTOR, front carb.	1	
23	AUD2178	€15.84	ADAPTOR, rear carb.	1	
24	AUC1329	€4.20	WASHER, adaptor	2	
25	AUD3017	€5.64	BOLT, chamber to body	2	
26	AUC1317	€1.44	WASHER, plain	2	
27	AUC1318	€5.40	WASHER, rubber	2	
30	AUE273	€117.00	LID & FLOAT ASSY, front	1	
31	AUE274	€117.00	LID & FLOAT ASSY, rear	1	
32	WZX1101A†	€16.56	NEEDLE & VALVE SEAT, Viton tip	2	
	373-626	€18.48	NEEDLE & VALVE SEAT, Viton, tip	2	aftermarket
33	GAC9201X	€13.44	GROSE-JET, superior replacement	2	
34	AUC1152	€1.20	PIN	2	
35	WZX1300	€21.24	FLOAT (as illustrated, with metal hinge tab)	2	
	378-471	€0.72	SHIM, .015"	A/R	

Note: Older SU replacement floats have moulded bosses for the pin. To use these and obtain the correct 1/16"-3/16" gap between the float and lid, shim(s) may be required under the needle & seat assembly.

36	AUC8459A†*	€2.64	GASKET, float chamber lid	2	
37	JZX1394	€1.68	SCREW, float chamber lid	6	
38	GHF331	€0.84	WASHER, locking	6	
39	NA		OVERFLOW PIPE, front & rear carbs.	2	
40	WZX1178†	€22.20	SHAFT, throttle, std.	2	
	WZX1178RP	€28.92	SHAFT, throttle, oversize	2	
41	WZX1321†	€18.00	DISC, throttle	2	
42	AUC1358†	€1.80	SCREW	4	
43	AUD3080†	€5.88	BUSH, throttle shaft	4	
44	372-800	NA	LEVER, throttle return, front carb.	1	
45	AUD2197	NA	LEVER, throttle return, rear carb.	1	
46	372-850	NA	LEVER, lost motion, front & rear carbs.	2	
47	AUC2106	€1.92	PIN, tapered	2	
48	AJD8014Z	€0.72	NUT, for lever, front & rear carbs.	2	
49	AUD3323	€1.56	WASHER, tab	2	
50	AUC2625	€1.32	WASHER, brass	2	
51	AUC8483	NA	SCREW, throttle stop	4	
52	AUC2451	€1.56	SPRING	4	
53	AUD9091	€31.32	PICK-UP LEVER & LINK ASSEMBLY	1	front carb, original
	LZX1274	€27.48	PICK-UP LEVER & LINK ASSEMBLY	1	front carb, replacement
54	AUD9090	NA	PICK-UP LEVER & LINK ASSEMBLY	1	rear carb, original
	LZX1275	€27.48	PICK-UP LEVER & LINK ASSEMBLY	1	rear carb, replacement
58	372-900	NA	LEVER, cam, front carb.	1	
59	AUD3346	€17.04	LEVER, cam, rear carb.	1	
60	WZX1335	€8.64	SPRING, for pick-up lever, front carb.	1	
61	WZX1336	NA	SPRING, for pick-up lever, rear carb.	1	
62	AUD2431	€3.48	SPRING, for cam lever, front carb.	1	
63	AUD2049	€1.80	SPRING, for cam lever, rear carb.	1	
64	AB606051	€0.84	SCREW, self-tapping	2	
65	WZX1331	€15.48	PIVOT BOLT ASSEMBLY	2	
70	AUE586	€4.44	LEVER, lost motion pick-up, front carb	1	
71	AUE587	€4.44	LEVER, lost motion pick-up, rear carb	1	
72	AUC2694	€1.56	BOLT	2	
73	AUC8396	€1.08	WASHER, plain	2	
74	AJD8012Z	€0.72	NUT	2	
75	NA		SHAFT, carb. coupling	1	
76	NA		BALL END	1	
77	GHF332	€0.84	WASHER, locking	1	

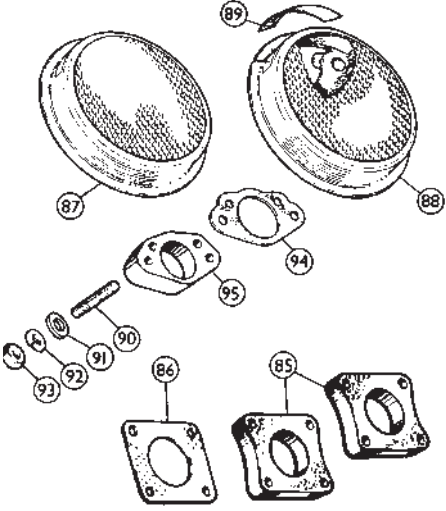
ill.	Part Number	Price €ea.	Description	Req.	Details
					
	85	GUG705602GM	€20.52	SPACER	4
	86	112867†*	€1.20	GASKET, carb. mounting	2
	87	11B621	€54.72	AIR FILTER, front	1
	88	AHB9909	€54.72	AIR FILTER, rear, with breather fitting	1
	89	215-691	€2.64	DECAL, air filters, Coopers	2
	90	NA		STUD, front air filter to carb.	2
		NA		STUD, rear air filter to carb.	2
	91	GHF301	€0.60	WASHER, plain	4
	92	GHF332	€0.84	WASHER, locking	4
	93	GHF201	€0.84	NUT	4
	94	112892†*	€2.16	GASKET, air filter to carb.	2
	95	NA		SPACER, rear air filter to carb.	1

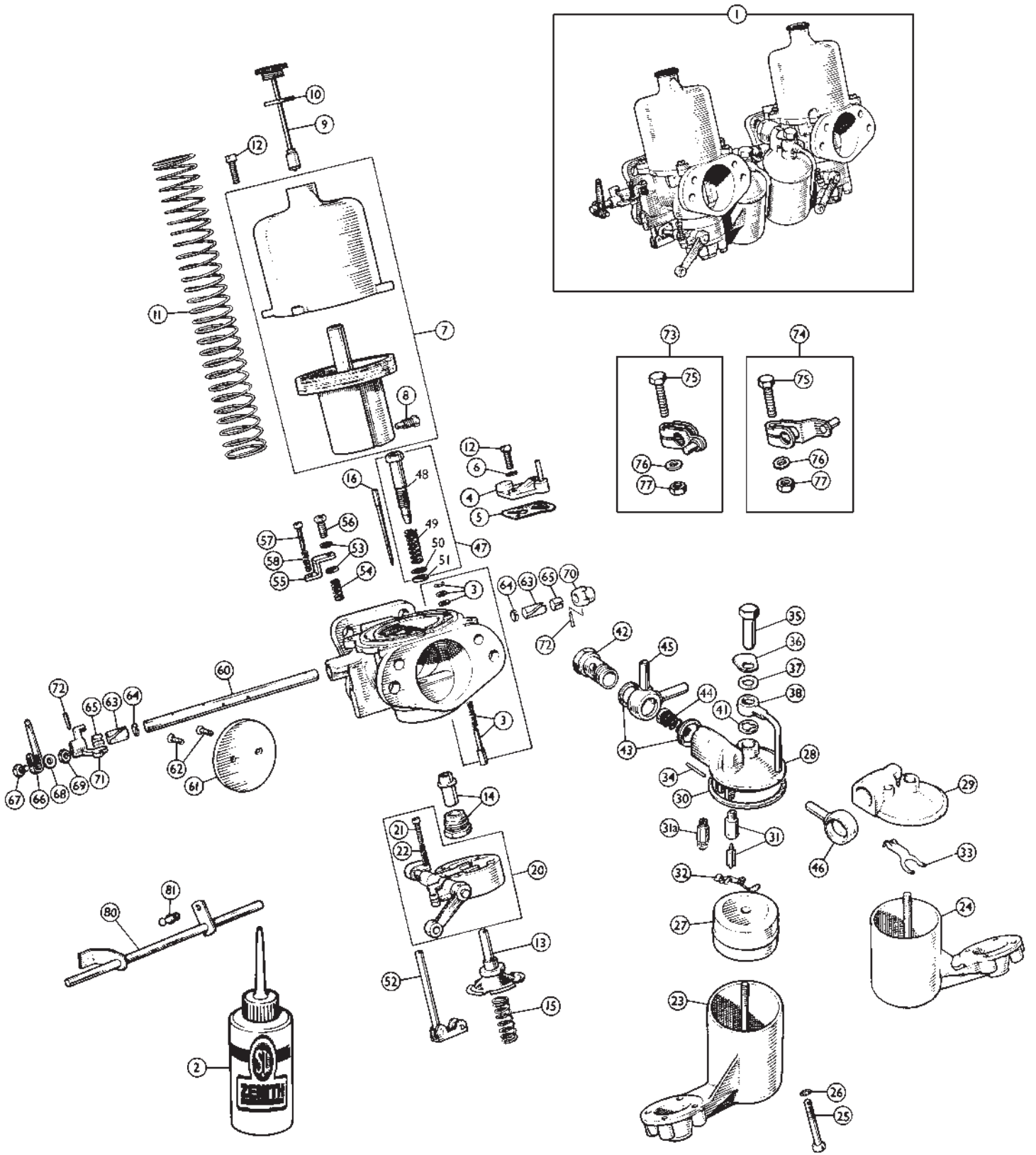

Ill.	Part Number	Price €ea.	Description	Req.	Details
HD8 Type Carburettors BJ8					
1	AUD124T	€2,989.20	CARBURETTOR SET	1	(AUD124)
2	GGL819201	€8.52	DYNOLITE DAMPER OIL, 125 ml.	A/R	
	375-595†	€197.28	MASTER REBUILD KIT, for two carbs	1	
	375-595	€197.28	REBUILD KIT, for one carburettor	2	
	375-328	€183.12	REBUILD KIT, for two carbs.	1	
	698-088	€16.80	GASKET KIT, for two carbs	1	
Master rebuild kits include items marked † Rebuild kits include items marked *					
3	WZX1110	€9.72	PIN & SPRING ASSEMBLY	2	
4	373-124	NA	ADAPTOR, vacuum advance	1	
5	378-140†*	€1.80	GASKET, for adaptor	1	
6	WL700101	€1.20	WASHER, shakeproof	2	
7	373-125	NA	CHAMBER & PISTON ASSEMBLY	2	
8	AUC2057	€4.20	SCREW, needle locking	2	
9	AUC8112	€36.36	CAP & DAMPER (SU replacement - does not use washer)	2	
10	AUC2141†*	€0.84	WASHER, fibre	2	orig. dampers only
11	AUC4826	€17.40	SPRING, piston return, red & green	2	
12	JZX1394	€1.68	SCREW	10	
13	AUC8156†*	€40.92	JET ASSEMBLY, 0.125	2	
14	WZX1211	€8.64	JET BEARING KIT	2	
15	AUC2006	€2.52	SPRING, jet return	2	
16	AUD1474	€27.12	NEEDLE, jet, rich (UN)	2	
	AUD1370	€27.12	NEEDLE, jet, std. (UH)	2	
	374-350	€27.12	NEEDLE, jet, lean (UL)	2	
20	373-090	NA	HOUSING ASSEMBLY, jet	2	
21	AUC8483	NA	SCREW, jet adjusting	2	
22	AUC2451	€1.56	SPRING	2	
23	AUC2062	NA	CHAMBER, float, front	1	
24	AUC2067	NA	CHAMBER, float, rear	1	
25	AUC2110	€6.12	BOLT, chamber to body	8	
26	WL700101	€1.20	WASHER, shakeproof	8	
27	WZX1303	€27.00	FLOAT, orig. type, brass	2	
	WZX1303X	€23.16	FLOAT, Nitrophenyl replacement	2	
28	AUE478	€126.84	LID, float chamber, front	1	inc. items 30, 31, 33, 34
29	AUE479	€126.84	LID, float chamber, rear	1	
30	AUC1147A†*	€1.56	GASKET, float chamber lid	2	
31	WZX1102A†*	€21.36	NEEDLE & SEAT ASSY, "Viton" tip	2	
31a	GAC9201X	€13.44	GROSE-JET, superior replacement	2	
32	AUC1980	€13.32	LEVER, hinged	2	for original lid
33	AUD2285	€9.24	LEVER, hinged	2	for replacement lid
34	AUC1152	€1.20	PIN	2	
35	AUC1867X	€10.08	CAP NUT, standard length	2	
	370-151	NA	CAP NUT, extended length	2	

Note: Catches available threads on a broken centre stud.

36	408-495	€8.40	TAG, carb. identification	2	Blank
37	AUC1557†*	€0.96	WASHER, aluminium	2	
38	AUC1866	€23.40	BANJO VENT & DRAIN PIPE	2	cut pipe to fit
41	AUC1928†*	€1.56	WASHER, fibre	2	
42	AUC2698	€7.56	BOLT, banjo	2	
43	AUC2141†*	€0.84	WASHER, fibre	4	
44	AUC2139	€13.80	FILTER & SPRING	2	
45	370-175	€67.80	BANJO UNION, front, double	1	brass (as orig.)
46	BHH1940	€9.72	BANJO UNION, rear, single	1	brass (as orig.)
	370-186	€55.08	BANJO UNION, rear, single	1	steel replacement
47	WZX992	€20.88	SLOW RUNNING VALVE SCREW KIT	2	
48	031-996	€17.52	SCREW, slow running	2	
49	031-997	€3.72	SPRING	2	
50	AUC2030†*	€2.04	WASHER, cupped	2	
51	AUC2029†*	€2.88	WASHER, rubber	2	
52	AUC8962	€101.52	CAM SHOE & ROD ASSEMBLY	2	
	WZX1235	€30.36	CAM SHOE KIT	2	inc. nos. 53-58
53	WL700101	€1.20	WASHER, shakeproof	4	
54	NA		SPRING, for rod	2	
55	NA		PLATE, top	2	
56	NA		SCREW, plate retaining	2	
57	AUC8483	NA	SCREW, stop adjusting	2	
58	AUC2451	€1.56	SPRING	2	
60	011-187†	€35.04	SHAFT, throttle, std.	2	
	011-188	€32.40	SHAFT, throttle, oversize	2	
61	WZX1373†	€21.36	DISC, throttle	2	
62	AUC1358†	€1.80	SCREW	4	
63	AUD2424†	€1.68	BUSH, throttle shaft	4	
64	NA		RING, inner	4	
65	NA		RING, outer	4	
66	373-126	NA	LEVER, throttle, front & rear carbs.	2	
67	AUC2694	€1.56	BOLT	2	
68	AUC8396	€1.08	WASHER, plain	2	
69	AJD8012Z	€0.72	NUT	6	
70	372-850	NA	LEVER, lost motion	2	
71	373-200	NA	STOP, throttle	2	
72	AUC2106†	€1.92	PIN, tapered	4	
73	AUE586	€4.44	COUPLING, with pin, front	1	
74	AUE587	€4.44	COUPLING, with pin, rear	1	
75	AUC2694	€1.56	BOLT	4	
76	AUC8396	€1.08	WASHER, plain	4	
77	AJD8012Z	€0.72	NUT	4	
80	021-925	€73.68	SHAFT ASSEMBLY, carb. coupling	1	
81	NA		BALL END	1	

Ill. Part Number Price €ea. Description Req. Details

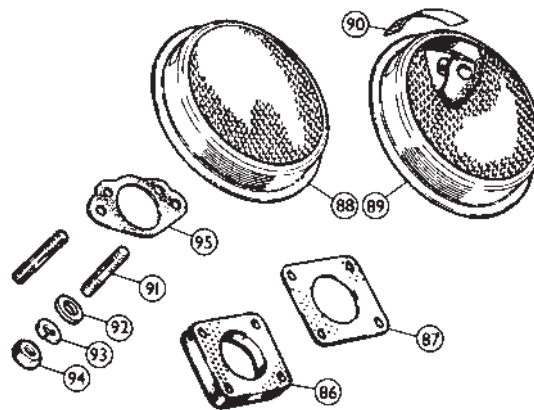

86	696-070	€25.56	INSULATING BLOCK	2	heat shield to manifold
87	C7221†*	€1.20	GASKET, heat shield to carburettor	4	
88	AHB6002	€48.00	AIR FILTER, front	1	
89	AHB6003	€54.72	AIR FILTER, rear	1	
90	215-691	€2.64	DECAL, air cleaners, Coopers	2	

Note: Correct water transfer decal in exactly proper colours.

91	NA		STUD	4	
92	GHF301	€0.60	WASHER, plain	4	
93	GHF332	€0.84	WASHER, locking	4	
94	GHF201	€0.84	NUT	4	
95	AHB6019	€2.76	GASKET, air filter to carb. (stock type)	2	
	053-269	€26.28	GASKET, air filter to carb.	2	0.15" cork for better sealing

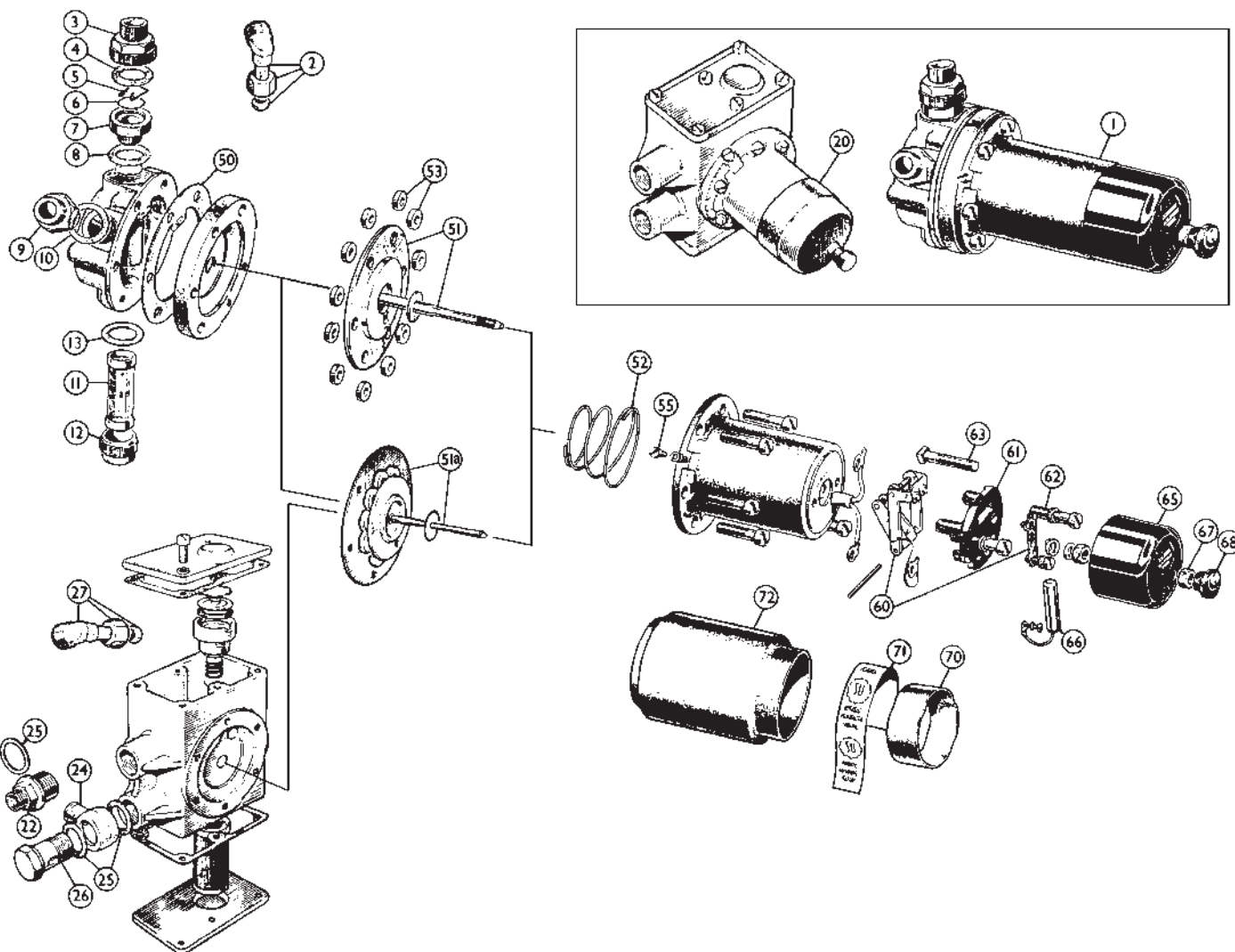

ill. Part Number Price €ea. Description Req. Details

Fuel Pumps BN1 to early BJ8

Pump Assemblies and Valve Housing: BN1, BN2; BN4 to C.E.60412

Part Number	Price €ea.	Description	Req.	Details
1 AZX1331	€222.60	FUEL PUMP, new SU	1	
2 MM375-038	€25.20	REPAIR KIT, fuel pump	1	
3	NA	UNION, 3 piece	1	
4 AUA1442	€0.96	WASHER, outlet union	1	
5	NA	CLIP	1	
6	NA	DISC, valve	2	
7	NA	VALVE CAGE, outlet	1	original pumps
8	NA	VALVE CAGE, outlet	1	replacement pumps
9	NA	WASHER, valve cage	1	
10 AUA1405	€1.68	WASHER, inlet union	1	
11 AUA1464	€11.52	FILTER	1	
12	NA	PLUG, filter	1	
13	NA	WASHER, plug	1	

Pump Assemblies and Valve Housing: BN4 from C.E. 60413, BN6, BN7, BT7, BJ7; BJ8 to (c)28224

20 AUA157	€498.00	FUEL PUMP, new SU square body	1	
22 *	NA	UNION, inlet & outlet	2	BN4 from C.E.60413
*	NA	UNION, inlet & outlet	2	BN6, BN7, BT7 to (c)17351
24 AUC1833	€15.60	UNION, banjo, inlet & outlet	2	
25 AUC2141	€0.84	WASHER, union	4	BT7 from (c)17352,
26 AUC2698	€7.56	BOLT, banjo union	2	BJ7, BJ8 to 28224
27 MM375-038	€25.20	UNION, 3 piece	1	

ill. Part Number Price €ea. Description Req. Details

Pump Body

50 AUA4082	€2.28	GASKET	2	original pumps
	NA	GASKET	1	replacement pumps
51 AUB6098	€55.92	DIAPHRAGM, 2-3/8" stem, flat cen.	1	BN1, BN2 (orig. pumps)
51a WZX1710	€56.40	DIAPHRAGM, 2-3/8" stem, step cen.	1	BN1, BN2 (repl. pumps)
AUB6099	€65.16	DIAPHRAGM, 3" stem	1	square body pump #20
52	NA	SPRING	1	
53	NA	ROLLER	11	
55	NA	SCREW, grounding, 2BA	1	original pumps
	NA	SCREW, grounding, 4BA	1	replacement pumps
	NA	CONTACT POINTS, single	1	BN1, BN2, BN4 to C.E.60412
		(No longer available. Use later double contact points.)		
60 AUB6106A	€21.36	CONTACT POINTS, double	1	BN4 from C.E.60413 - BJ8
61 AUB6034	€19.08	PEDESTAL	1	
62	NA	SCREW, pedestal to housing	2	
63	NA	SCREW, terminal	1	
65 AUA1466	€11.52	CAP, flat	1	original pumps
AUA5078	€12.96	CAP, stepped	1	replacement pumps
66 CZX1004	€14.64	DIODE (replaces condenser)	1	
67	NA	NUT	1	
68 AUA869	NA	KNOB, terminal	1	
70	NA	SLEEVE	1	later style
71 CRST212	€4.44	DECAL	1	printed with 'SU' logos
72 AC65147	€14.76	COVER, rubber	1	earlier style

*Original pumps had a 2BA (.187" dia.) ground screw #55. Replacement pumps used a 4BA (.137" dia.) screw. Note the different diaphragm centre washer configurations.

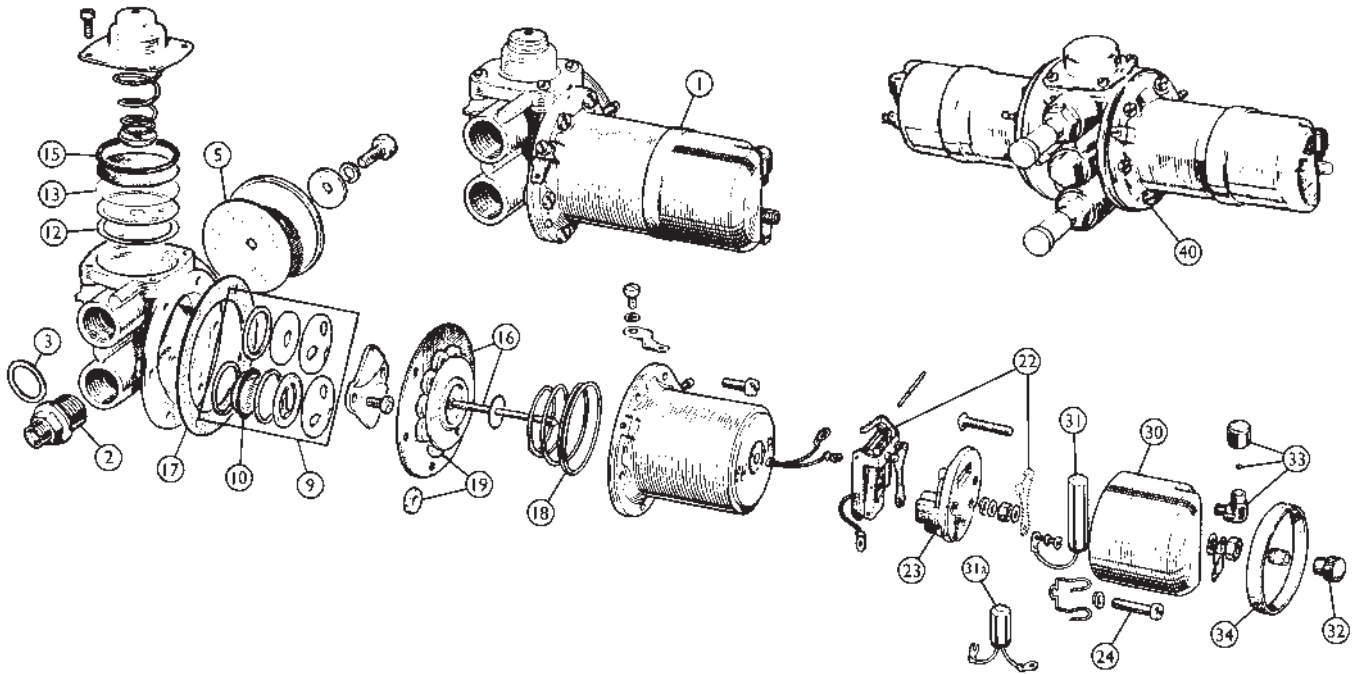

iii. Part Number Price €ea. Description Req. Details

Fuel Pump, BJ8 from (c)28225

1	AZX1307	€222.60	FUEL PUMP, new SU	1	
These new pumps are not polarity sensitive, and work with positive or negative ground.					
2	NA		UNION, inlet & outlet (suggest 376-108 Hose & Fitting Kit - see bottom of page 34)	2	
3	AUC2141	€0.84	WASHER, union, fibre	2	original & older SU pumps
	AUB654	€1.20	"O" RING, union	2	current SU pumps
5	NA		GASKET, side cover	1	
9	NA		VALVE REPAIR KIT,	1	
10	AUB617	€5.88	FILTER	1	
12	NA		GASKET, plate	1	
13	NA		DIAPHRAGM, nylon	1	
15	NA		RING, sealing	1	replacement pumps
	NA		DIAPHRAGM, nylon	1	
	NA		RING, sealing	1	
16	WZX1710	€56.40	DIAPHRAGM, 2-3/8" stem	1	
17	AUB809	€2.76	GASKET, diaphragm	1	
18	NA		SPRING	1	
19	NA		ROLLER	11	original pumps
22	AUB6106A	€21.36	POINTS, fuel pump	1	
23	AUB6034	€19.08	PEDESTAL	1	
24	NA		SCREW, pedestal to housing	2	
30	AUB707	€14.28	CAP	1	
31	CZX1004	€14.64	DIODE (replaces condenser)	1	
31a	377-135	NA	DIODE, positive ground	1	fitted to some previous replacement pumps
	CZX1004	€14.64	DIODE, negative ground	1	
32	AUA869	NA	KNOB, terminal	1	
33	NA		VENT VALVE KIT	1	
34	NA		RING, sealing	1	

Competition Pumps

40	377-036	€513.60	FUEL PUMP, new SU	1	rated at 30 gal. per hr.
----	---------	---------	-------------------	---	--------------------------

These new pumps are not polarity sensitive, and work with positive or negative ground.

AHH6709	€14.76	BRACKET, mounting	2
AHH6708	€3.48	SLEEVE, rubber	2

iii. Part Number Price €ea. Description Req. Details

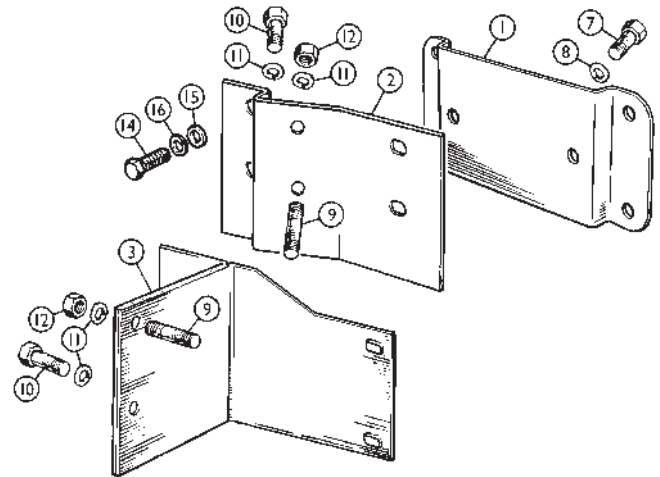

Pump Mountings: All Models

AJD6155Z	€1.56	BOLT, pump to body	2	BN1, BN2	
GHF331	€0.84	WASHER, locking	2		
1	377-240	€35.04	BRACKET, pump mounting (round)	1	BN4 to C.E.60412
2	377-250	NA	BRACKET, pump mounting (square) (BN6 & BN7 did not use a bracket)	1	BN4 from C.E.60413 & BT7 to (c)17351
3	377-260	€37.20	BRACKET, pump mounting (round)	1	BT7 from (c)17352, BJ7, BJ8
7	SH604041	€0.84	BOLT, pump to bracket (round)	2	BN4 to C.E.60412
8	GHF332	€0.84	WASHER, locking	2	
9	NA	NA	STUD, pump mounting (square)	2	BN4 from C.E.60413, BN6, BN7, BT7, BJ7, BJ8
10	320-360	€1.92	BOLT, alternative to stud	2	
11	GHF332	€0.84	WASHER, locking	2	
12	GHF201	€0.84	NUT	2	
14	SH604041	€0.84	BOLT, bracket to body	4	BN4 thru BJ8
15	GHF300	€1.08	WASHER, plain	4	
16	GHF331	€0.84	WASHER, locking	4	

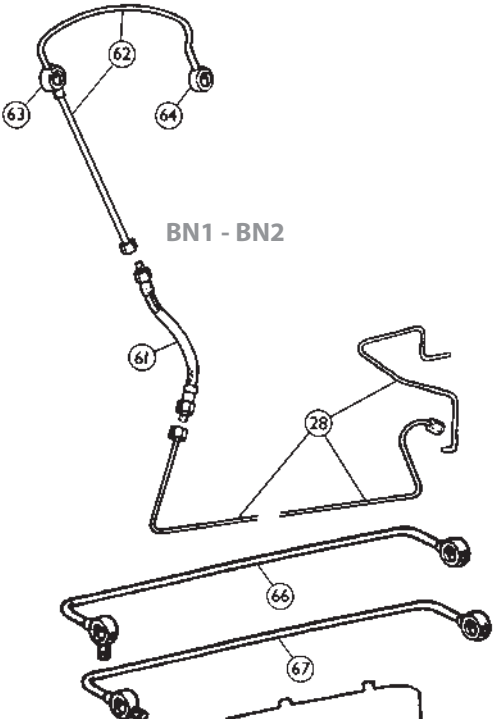
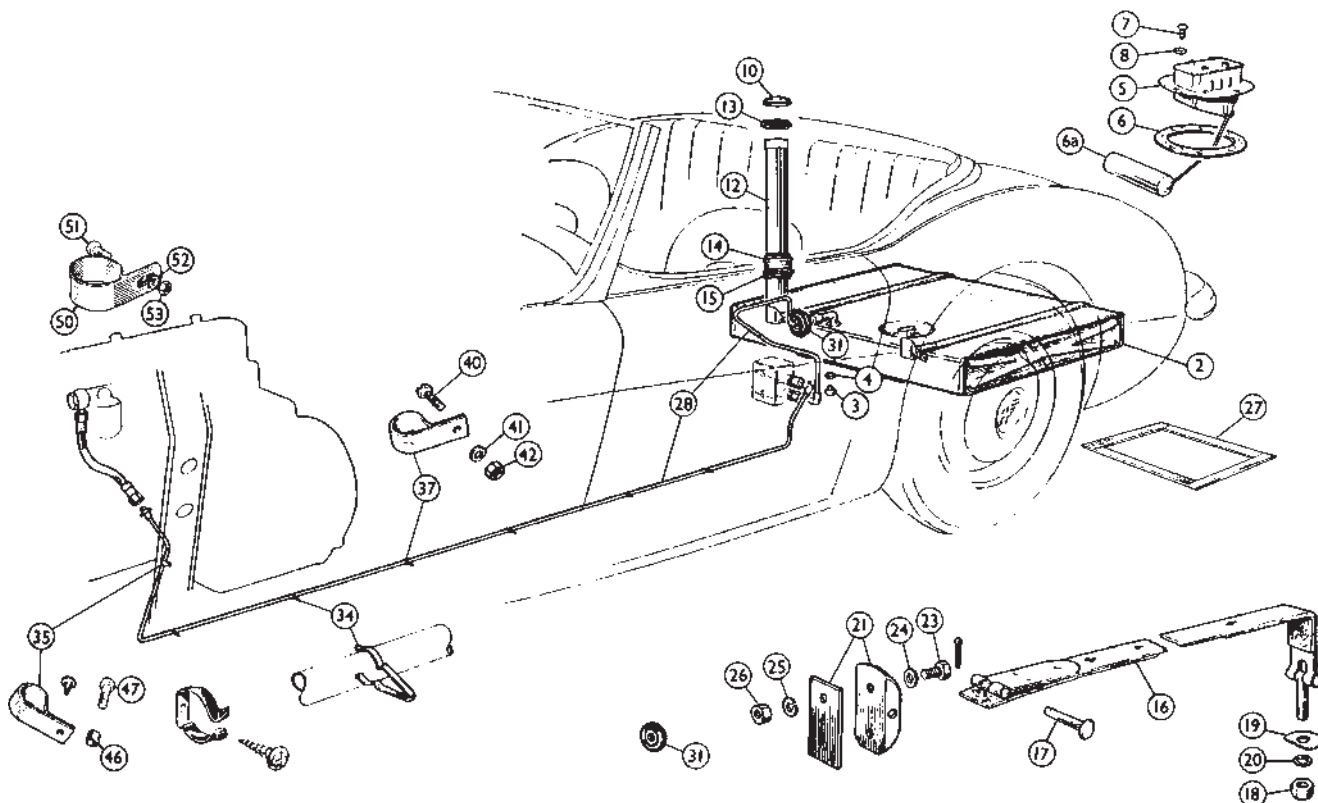

BN1 - BN2

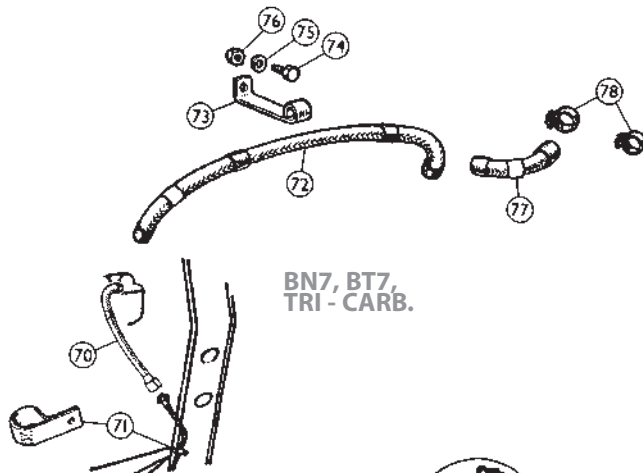

BN7, BT7, TRI - CARB.

BN4, BN6, BN7, BT7, TWIN CARB.

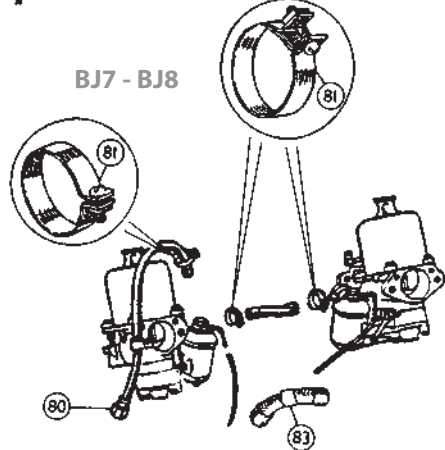
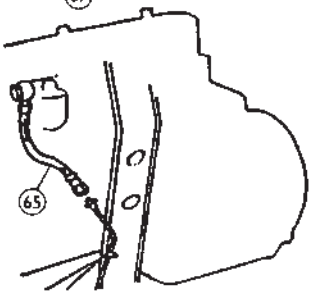

BJ7 - BJ8

Ill.	Part Number	Price €ea.	Description	Req.	Details
Fuel Tanks, Pipes & Pumps					
Fuel Tank; Supply Pipes to Engine Bay					
2	849-070	€816.00	FUEL TANK, steel	1	BN1, BN2
	849-075	€775.20	FUEL TANK, aluminium	1	
		NA	FUEL TANK	1	BN4 to C.E. 68959
	11B2375	€408.00	FUEL TANK, steel, Classic Gold	1	BN4 from C.E. 68960
	11B2375A	€700.80	FUEL TANK, aluminium	1	thru BJ8
3	88G257	€2.88	DRAIN PLUG	1	original tanks
4	6K638	€0.72	WASHER, copper	1	
5	1B2736	€66.96	SENDER UNIT, fuel tank	1	BN1, BN2, BN4, BN6, BN7, BT7, BJ7
	BHA4435	€66.96	SENDER UNIT, fuel tank	1	BJ8
6	2H1082	€1.32	GASKET, sender unit, cork	1	original type)
6a	360-645	€10.56	FLOAT, sender unit, plastic	1	included w/ senders)
	360-646	€16.56	FLOAT, sender unit, brass	1	
	293-401	€6.72	GASKET SET, ethanol proof	1	mounting & cover gaskets)
7	53K165	€1.32	SCREW	6	
8	2A2088	€0.84	WASHER, copper	6	
10	834-860	€66.96	FUEL FILLER CAP	1	BN1, BN2
	18G8601SS	€19.32	FUEL FILLER CAP, stainless steel	1	
	18G8601A	€10.80	FUEL FILLER CAP, chrome	1	
	AKF1439	€34.56	FUEL FILLER CAP, locking	1	
12	021-899	€66.96	FILLER NECK, fuel tank	1	BN4 thru BJ8
13	11G2100	€4.80	GROMMET, filler neck	1	
14	BHH191	€12.00	HOSE, filler neck to tank	1	
15	GHC11080	€6.24	CLIP, hose	2	
	021-898	NA	STRAP, tank to body	1	use late strap &
	021-919	€1.32	CLEVIS PIN, for straps	2	nuts BN1, BN2
	AJD8105Z	€0.72	NUT, for T bolts on straps	4	
16	851-310	€54.00	STRAP, tank to body	2	BN4 thru BJ8
17	021-919	€1.32	CLEVIS PIN, for straps	2	
18	NT605041	€0.84	NUT, for T bolts on straps	4	
19	14B2036	€3.60	"D" WASHER, for "T" bolts	2	
20	GHF332	€0.84	WASHER, locking	2	
21	021-868	€10.92	BRACKET & PLATE	2	
23	SH604051	€0.72	BOLT	4	
24	GHF300	€1.08	WASHER, plain	4	BN7, BT7, BJ7, BJ8
25	GHF331	€0.84	WASHER, locking	4	
26	GHF200	€0.96	NUT	4	
27	021-869	€18.72	SEALING RUBBER	1	BN1, BN2
	021-806	€18.48	SEALING RUBBER	1	BN4 thru BJ8
28	021-936	€76.08	PIPE SET	1	BN1, BN2
	021-897	€96.00	PIPE SET	1	BN4 thru BT7 to (c)17351
	021-896	€103.56	PIPE SET	1	BT7 from (c)17352, BJ7, BJ8

Note: These Pipe Sets include metal pipes from tank to pump, and from pump to front hose. Pipes are supplied coiled, and must be bent to correct configuration.

31		NA	GROMMET	1	BN1, BN2
	ACB8474	€2.76	GROMMET	1	BN4 to C.E.22593
	C5574A	€6.60	GROMMET	1	BN4 from C.E.22594, BN6, BN7, BT7, BJ7, BJ8
34	6K35	€1.44	CLIP, pipe to chassis	7	
35	CP105081	€1.92	CLIP, pipe to bonnet support	1	BN4 thru BT7 to (c)17351
37	CP105081	€1.92	CLIP, pipe to chassis	9	
40	PMZ308	€0.72	SCREW, heelboard clip	1	
41	GHF331	€0.84	WASHER, locking	2	BN7 from (c)17547, BT7
42	GHF206	€1.32	NUT	2	from (c)17352, BJ7, BJ8
46		NA	SPACER, for wheelarch clip	1	
47	SE910201	€1.08	SCREW, wheelarch clip	1	
50	PCR1007	€1.92	CLIP, hose to bonnet support	1	
51	PMZ305	€0.84	SCREW, for clip	1	BJ8
52	GHF331	€0.84	WASHER, locking	1	
53	GHF206	€1.32	NUT	1	

Fuel Lines in Engine Bay BN1, BN2

61	021-710	€33.84	HOSE	1	
62	021-918	€164.88	PIPE ASSEMBLY, carb. to carb.	1	
63	370-085	€81.12	BANJO FITTING, 2 inlet	1	must be brazed to pipes
64	370-125	€44.52	BANJO FITTING, 1 inlet	1	

BN4, BN6, BN7, BT7 (Twin Carburetors)

65	1E1238	NA	HOSE	1	BN4 to C.E.58726
	AHB5366	€14.28	HOSE	1	BN4 from C.E.58727, BN6, BN7 & BT7 to (c)13750
66	021-867	NA	PIPE ASSEMBLY, carb. to carb.	1	BN4 to C.E.48862
67	021-874	€149.64	PIPE ASSEMBLY, carb. to carb.	1	BN4 from C.E.48863, BN6, BN7 & BT7 to (e) 29D-H26212

BN7, BT7 (Triple Carburetors)

70	AHH6707	€12.36	HOSE (replacement, approx. 8" long)	1	
71	CP105081	€1.92	"P" CLIP, pipe to front carb.	5	
72	AEC2072	€24.48	HOSE, front to centre carb.	1	replaces original pipe
73	021-873	NA	BRACKET, pipe support	1	
74	SH604051	€0.72	BOLT	1	BN7 & BT7 from
75	GHF331	€0.84	WASHER, locking	1	(e) 29E-H929
76	GHF200	€0.96	NUT	1	

Ill.	Part Number	Price €ea.	Description	Req.	Details
77	GGT101	€4.80	HOSE, centre to rear carb.	1	
78	ACH5854	NA	CLIP, hose (orig. type)	5	
	GGT1117X	€2.52	CLIP, hose (replacement)	5	

BJ7, BJ8

80	376-820	NA	HOSE	1	BJ7
	AHB6715	€32.76	HOSE	1	BJ8
81	ACH5854	NA	CLIP, hose to front carb.	3	original type
	GGT1117X	€2.52	CLIP, hose to front carb.	3	replacement
83	GGT101	€4.80	HOSE, carb. to carb.	1	BJ7

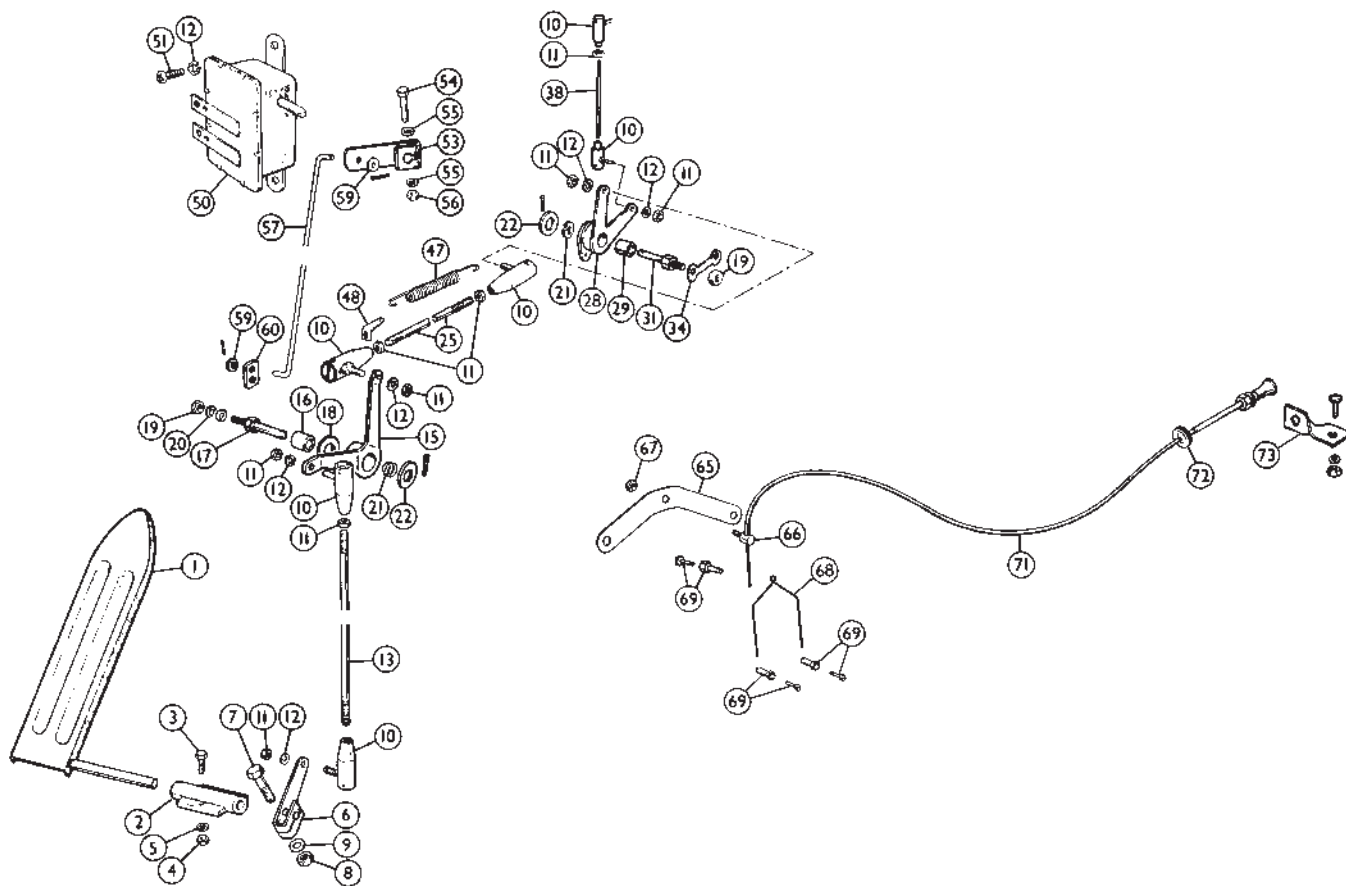

Part Number	Price €ea.	Description	Req.	Details
Engine Controls BN1, BN2 (LHD)				
1	372-365	€69.00 ACCELERATOR PEDAL & SHAFT	1	
2	021-888	€22.56 BRACKET, for shaft	1	
3	NA	SCREW	3	
4	GHF206	€1.32 NUT	4	
5	GHF331	€0.84 WASHER, locking	3	
6	021-695	€12.96 LEVER, pedal shaft	1	
7	GHF101	€0.72 BOLT	1	
8	GHF200	€0.96 NUT	1	
9	GHF300	€1.08 WASHER, plain	1	
10	021-892	NA BALL JOINT, for rod, B.A. thread	6	BN1 to C.E.223383
10	ACB5311	€18.96 BALL JOINT, for rod, UNF thread, original	6	BN1 from C.E.223384, BN2
11	AJD8012Z	NA BALL JOINT, for rod, UNF thread, plastic	6	(alt.)
11	GHF206	€0.72 NUT, 2 B.A. thread	9	BN1 to C.E.223383
11	GHF331	€1.32 NUT, UNF thread	9	BN1 from C.E.223384, BN2
12	GHF331	€0.84 WASHER, locking	11	
13	NA	CONTROL ROD, pedal shaft lever to relay lever, B.A. thread	1	
13	NA	CONTROL ROD, pedal shaft lever to relay lever, B.A. thread	1	BN1 C.148528 to C.E.223383
13	NA	CONTROL ROD, pedal shaft lever to relay lever, UNF thread	1	BN1 from C.E.223384, BN2
15	NA	BELLCRANK LEVER, accelerator relay	1	
16	NA	BUSH	1	
17	728-005	€21.96 FULCRUM PIN	2	threads into stock exhaust manifold
Note: If a header is fitted, it must have a tab welded on to support the fulcrum pin; only then is nut no. 19 used.				
18	NA	WASHER	1	
19	AJD8106Z	€0.96 NUT, BSF thread	2	used only with aftermarket header
20	GHF333	€0.72 WASHER, locking	1	
21	724-050	NA WASHER, double coil	2	
22	NA	WASHER, plain	2	
25	NA	CONTROL ROD, relay lever to bellcrank lever, B.A. thread	1	BN1 to C.E.223383

Part Number	Price €ea.	Description	Req.	Details
28	NA	CONTROL ROD, relay lever to bellcrank lever, UNF thread plastic, (alternative)	1	BN1 from C.E.223384, BN2
29	NA	BELLCRANK LEVER, on heatshield	1	
29	NA	BUSH	1	
31	728-005	€21.96 FULCRUM PIN	1	
31	GHF332	€0.84 WASHER, locking	1	
34	NA	TABWASHER	1	
38	NA	CONTROL ROD, bellcrank lever to throttle shaft lever	1	BN1 to C.E.223383
38	NA	CONTROL ROD, bellcrank lever to throttle shaft lever	1	BN1 from C.E.223384, BN2
47	NA	SPRING, accelerator return	1	
48	NA	BRACKET	1	
50	141-050	€122.64 THROTTLE SWITCH	1	
51	PMZ308	€0.72 SCREW, switch to bulkhead	2	
53	NA	LEVER, overdrive rotary switch, top	1	
54	NA	BOLT, lever to switch	1	
55	NA	WASHER, plain	2	
56	GHF206	€1.32 NUT	1	
57	NA	LINK, throttle to switch	1	
59	NA	WASHER, plain	2	
60	NA	EYE, for link	1	
Choke Cable, BN1, BN2 (LHD and RHD)				
65	378-025	€17.04 BRACKET, choke cable abutment	1	(not 100M)
66	378-560	€21.48 PIN & NUT, abutment, for outer cable	1	
67	GHF242	€3.00 LOCKNUT	1	
68	AUC1025	€14.40 STIRRUP, for connecting jet levers	1	
69	AUE35	€11.88 TRUNNION & SCREW	3	
71	734-100	€42.48 CHOKE CABLE	1	
72	RFN403	€1.80 GROMMET, choke cable	1	
73	378-035	€19.20 BRACKET, choke cable to parcel shelf	1	

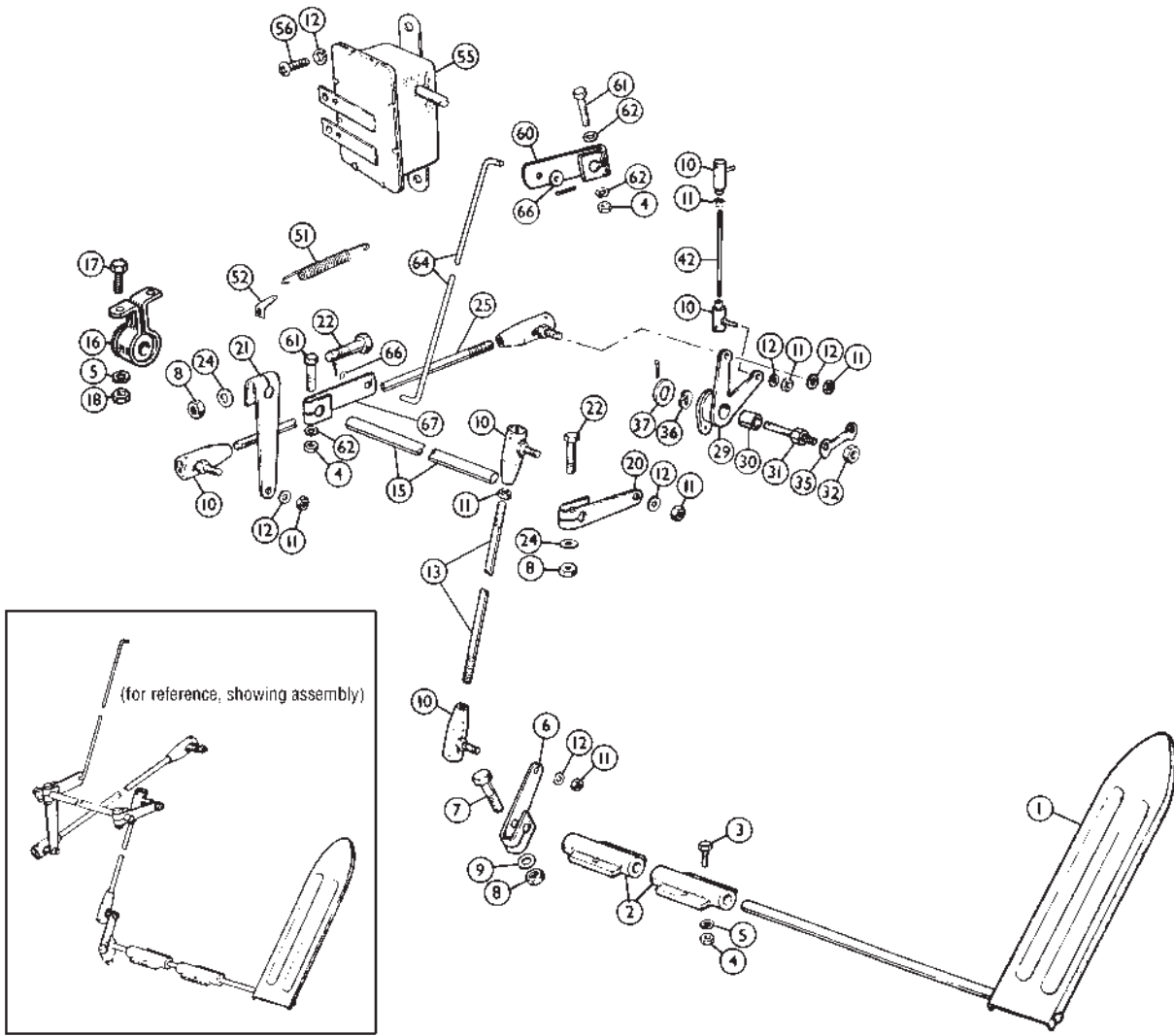

iii. Part Number Price €ea. Description Req. Details

Engine Controls BN1, BN2 (RHD)

1		NA	ACCELERATOR PEDAL & SHAFT	1	
2	021-888	€22.56	BRACKET, for shaft	2	
3		NA	SCREW	6	
4	GHF206	€1.32	NUT	8	
5	GHF331	€0.84	WASHER, locking	10	
6	021-695	€12.96	LEVER, pedal shaft	1	
7	GHF101	€0.72	BOLT	1	
8	GHF200	€0.96	NUT	3	
9	GHF300	€1.08	WASHER, plain	1	
10	021-892	NA	BALL JOINT, for rod, B.A.	6	BN1 to C.E.223383
	ACB5311	€18.96	BALL JOINT, for rod, UNF, original type	6	BN1 from C.E.223384, BN2
		NA	BALL JOINT, for rod, UNF, plastic	6	
11	AJD8012Z	€0.72	NUT, 2B.A.	9	BN1 to C.E.223383
	GHF206	€1.32	NUT, UNF	9	BN1 from C.E.223384, BN2
12	GHF331	€0.84	WASHER, locking	12	
13		NA	CONTROL ROD, pedal shaft lever to relay lever, B.A. thread	1	BN1 to C.148527
		NA	CONTROL ROD, pedal shaft. lever to relay lever, B.A thread	1	BN1 C.148528 to C.E.223383
		NA	CONTROL ROD, pedal shaft lever to relay lever, UNF thread	1	BN1 from C.E.223384, BN2
15		NA	RELAY ROD, accelerator	1	
16		NA	BEARING, for rod	2	
17		NA	SCREW	4	
18	GHF206	€1.32	NUT	4	
20		NA	LEVER, relay rod, RH	1	
21		NA	LEVER, relay rod, LH	1	
22		NA	BOLT	2	
24	GHF331	€0.84	WASHER, locking	2	
25		NA	CONTROL ROD, relay lever to bellcrank lever, B.A.	1	BN1 to C.E.223383
		NA	CONTROL ROD, relay lever to. bellcrank lever, UNF	1	BN1 from C.E.223384, BN2
29		NA	BELLCRANK LEVER, on heat shield	1	
30		NA	BUSH	1	

iii. Part Number Price €ea. Description Req. Details

31	728-005	€21.96	FULCRUM PIN (screws into stock exhaust manifold.)	1	
Headers must have a tab welded on to support this, and only then use nut no. 32.					
32	AJD8106Z	€0.96	NUT, BSF thread	1	used only w aftermarket header
35		NA	TABWASHER	1	
36		NA	WASHER, double coil, lever to fulcrum pin	1	
37		NA	WASHER, plain	1	
42		NA	CONTROL ROD, bellcrank lever to throttle shaft lever	1	BN1 to C.E.223383
		NA	CONTROL ROD, bellcrank lever to throttle shaft lever	1	BN1 from C.E.223384, BN2
51		NA	SPRING, accelerator return	1	
52		NA	BRACKET	1	
55	141-050	€122.64	THROTTLE SWITCH	1	
56	PMZ308	€0.72	SCREW, switch to bulkhead	2	
60		NA	LEVER, overdrive rotary switch, top	1	
61		NA	BOLT, lever to switch	2	
62		NA	WASHER, plain	2	
64		NA	LINK, throttle to switch	1	
66		NA	WASHER, plain	2	
67		NA	LEVER, overdrive rotary switch, bottom	1	

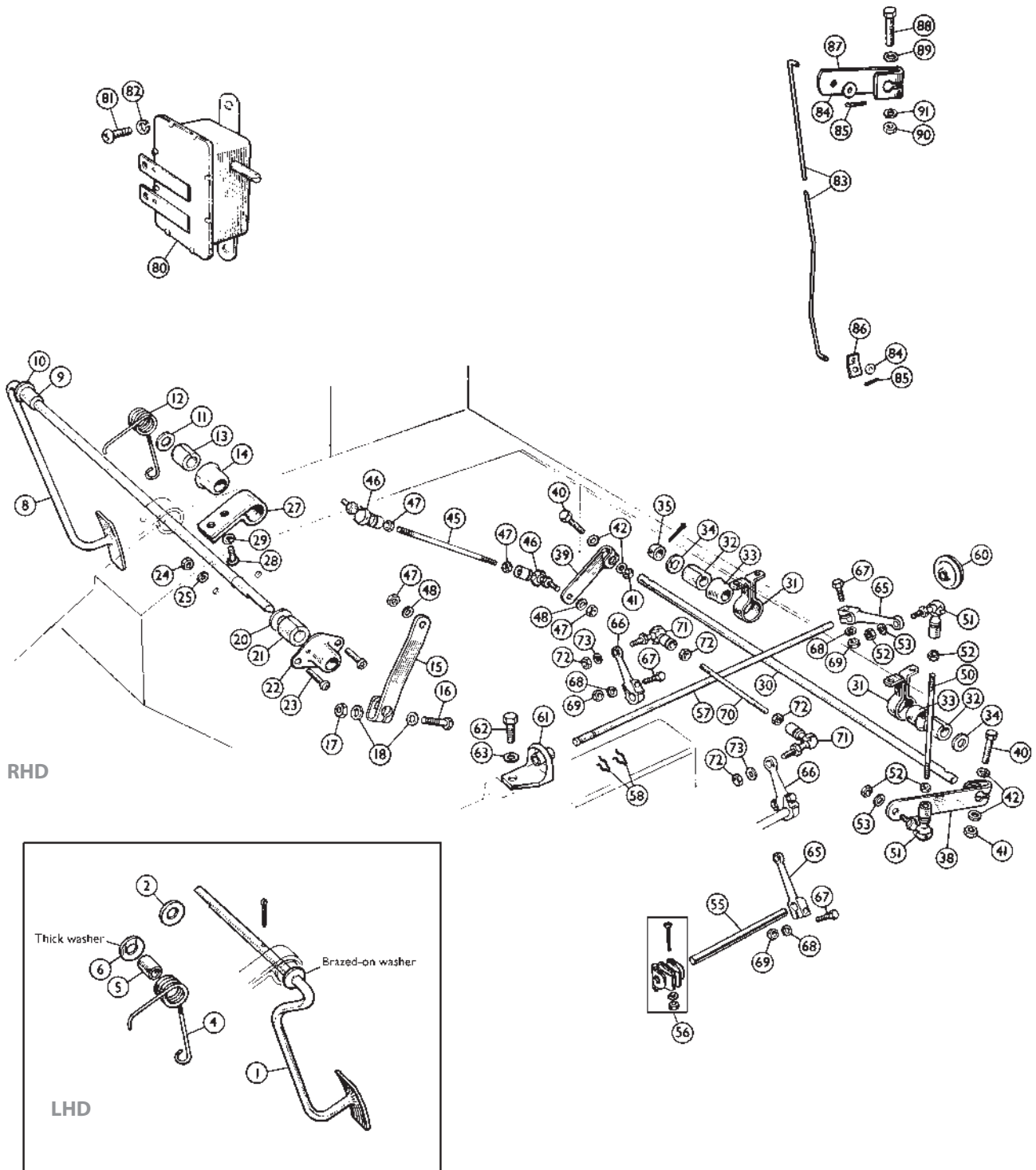

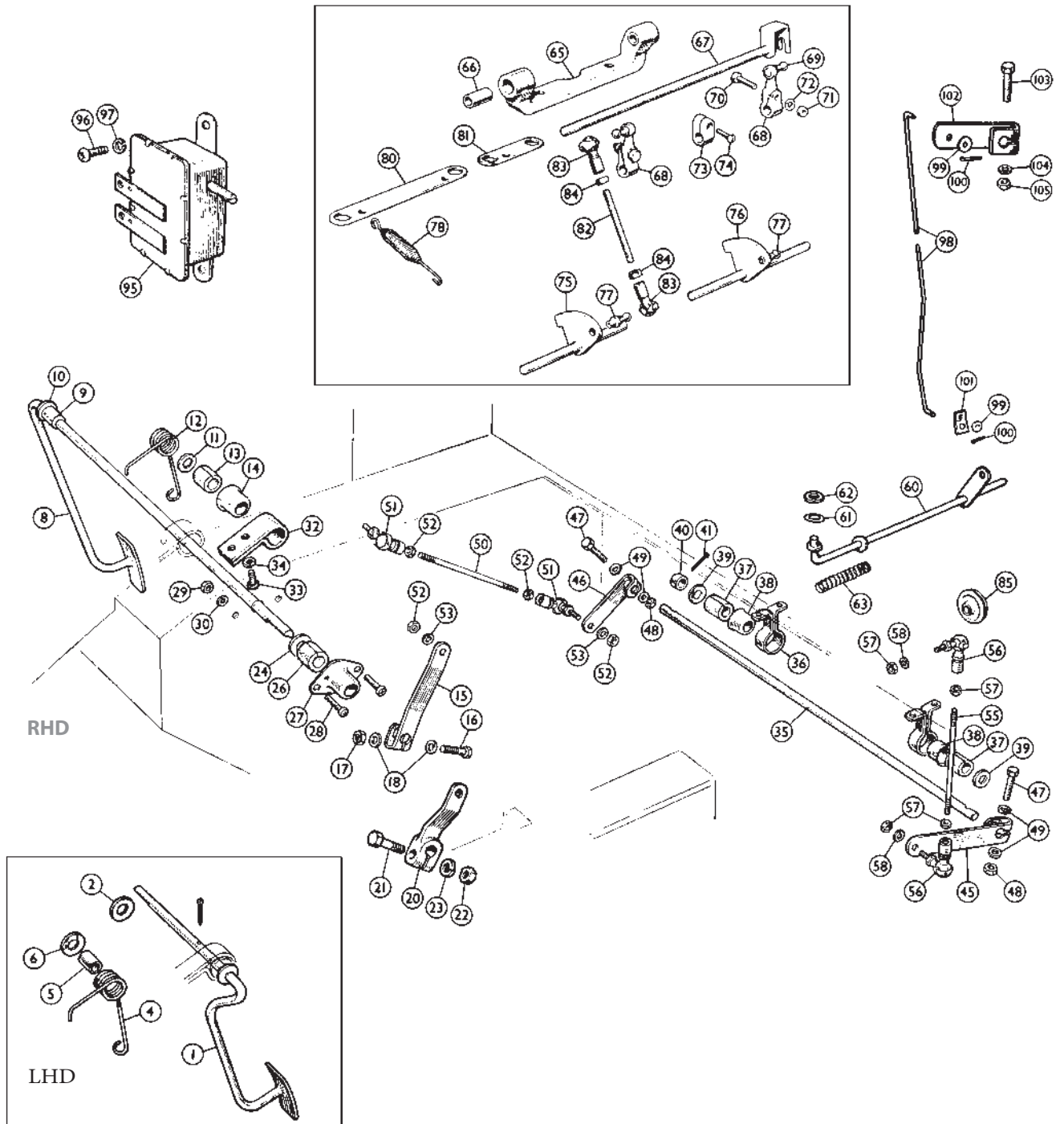

Part Number	Price €ea.	Description	Req.	Details
Tri-Carb Engine Controls BN7, BT7				
1	NA	ACCELERATOR PEDAL ASSY	1	LHD models
2	WP9 €2.04	WASHER, for rod	1	
4	021-924 €19.56	SPRING, pedal return	1	
5	NA	COLLAR, return spring location	1	
6	NA	WASHER, return spring location	1	
8	NA	ACCELERATOR PEDAL & SHAFT	1	BN7 to (c)16038, BT7 to (c)15880, RHD models
	NA	ACCELERATOR PEDAL & SHAFT	1	BN7 from 16039, BT7 from 15881, RHD models
9	NA	COLLAR	1	
10	NA	WASHER	1	RHD models
11	WP9 €2.04	WASHER, for rod	1	
12	NA	SPRING, pedal return	1	
13	NA	BUSH, felt (see pg. 43 for Teflon replacement set)	1	
14	NA	CUP, for bush	1	
15	021-697 €17.16	LEVER, pedal shaft	1	
16	GHF101 €0.72	BOLT, lever to pedal shaft	1	BN7 & BT7 to (c)15103
17	GHF200 €0.96	NUT	2	
18	GHF300 €1.08	WASHER, plain	2	
20	NA	LEVER, pedal shaft	1	
21	GHF103 €1.20	BOLT, lever to pedal shaft	1	BN7 & BT7 from (c)15104
22	GHF201 €0.84	NUT	1	
23	GHF332 €0.84	WASHER, locking	1	
24	WP9 €2.04	WASHER	1	
26	021-922 €2.16	BUSH	1	
27	021-951 €48.96	CUP, for bush	1	
28	SE604051 €0.84	SCREW, cup to pedal box	2	
29	GHF206 €1.32	NUT	2	
30	GHF331 €0.84	WASHER, locking	1	
32	NA	SUPPORT, accelerator shaft	1	BN7 & BT7 to (c)14377
33	NA	SCREW	2	
34	GHF331 €0.84	WASHER, locking	2	
35	NA	RELAY SHAFT, accelerator (plain; uses levers 45 and 46)	1	BN7 & BT7 from (c)14378, LHD models
	NA	RELAY SHAFT, accelerator (with integral levers)	1	BN7 & BT7 from (c)14378, RHD models
	NA	RELAY SHAFT, accelerator (with integral levers)	1	
36	NA	MOUNTING BRACKET	2	
37	021-922 €2.16	BUSH, felt	2	
38	NA	CUP, for bush	2	
39	WP9 €2.04	WASHER	2	
40	NA	COLLAR	1	LHD models
41	GHF502 €1.08	SPLIT PIN	1	
45	021-692 €13.56	LEVER, accelerator relay shaft, long	1	BN7 & BT7 to (c)14377
46	021-690	LEVER, accelerator relay shaft, short	1	
47	GHF101 €0.72	BOLT	2	BN7 & BT7 to (c)14377
	GHF101 €0.72	BOLT	1	BN7 & BT7 from (c)14378, RHD models
48	GHF200 €0.96	NUT	2	BN7 & BT7 to (c)14377; BN7 & BT7 from (c)14378, RHD models
49	GHF300 €1.08	WASHER, plain	4	BN7 & BT7 to (c)14377
	GHF300 €1.08	WASHER, plain	2	BN7 & BT7 from (c)14378, RHD models
50	NA	CONTROL ROD, pedal shaft to relay lever	1	
51	ACB5311 €18.96	BALL JOINT, for rod	2	
52	GHF206 €1.32	NUT	4	
53	GHF331 €0.84	WASHER, locking	2	
55	NA	CONTROL ROD, relay shaft to accelerator spindle	1	
56	ACB5311 €18.96	BALL JOINT, for rod	2	
57	GHF206 €1.32	NUT	4	
58	GHF331 €0.84	WASHER, locking	2	
60	NA	SPINDLE ASSEMBLY, accelerator	1	
61	NA	WASHER, anti-rattle	1	
62	GHF301 €0.60	WASHER, plain	1	
63	ACH8508 €3.72	SPRING	1	
65	NA	BRACKET, countershaft support	1	BN7 & BT7 from (e)29E-H101 to (e)29E-H928
	NA	BRACKET, countershaft support	1	BN7 & BT7 from (e)29E-H929
66	NA	BUSH, countershaft support bracket	2	
67	NA	COUNTERSHAFT, throttle control	1	
68	NA	LEVER, countershaft	2	
69	NA	BALL END	2	
70	AUC2694 €1.56	BOLT	2	
71	AJD8012Z €0.72	NUT	2	
72	GHF331 €0.84	WASHER, locking	2	
73	NA	STOP, countershaft	1	
74	NA	SCREW	1	
75	NA	LEVER, throttle, front	1	
76	NA	LEVER, throttle, rear	1	
77	NA	BALL END	2	
78	AEC2075 €2.64	SPRING, throttle return	3	
80	NA	BRACKET, spring retaining, front & centre	2	
81	NA	BRACKET, spring retaining, rear	1	
82	NA	ROD, throttle connecting	2	
83	ACB5311 €18.96	SOCKET, ball joint (discard ball end)	4	
84	AJD8012Z €0.72	NUT	4	
85	AHB8944 €8.52	BEARING, relay shaft, in bulkhead	1	
95	141-050 €122.64	THROTTLE SWITCH	1	
96	PMZ308 €0.72	SCREW, switch to dash	2	

Part Number	Price €ea.	Description	Req.	Details
97	GHF331 €0.84	WASHER, locking	2	
98	021-329	LINK, throttle switch	1	
99	NA	WASHER, plain	1	
100	NA	SPLIT PIN	2	
101	021-335	EYE, for link	1	
102	NA	LEVER, throttle switch, top	1	
103	53K129 €2.64	BOLT	1	
104	NA	WASHER, plain	2	
105	GHF206 €1.32	NUT	1	

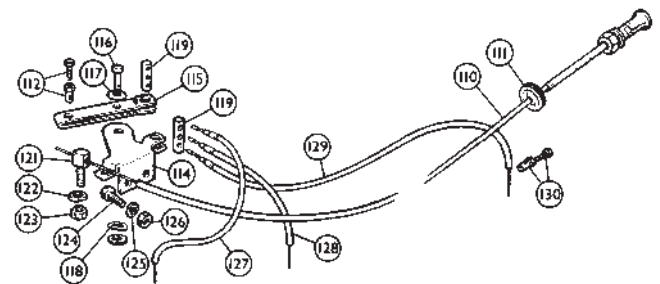

Choke Cables

110	734-130 €23.88	CHOKE CABLE (replacement)	1	
111	RFN403 €1.80	GROMMET, choke cable	1	
112	AUE34 €3.72	CABLE STOP, cable to coupling	1	
114	NA	BODY, coupling assembly	1	
115	NA	LEVER	1	
116	NA	PIN, clevis	1	
117	GHF300 €1.08	WASHER, plain	2	
118	NA	WASHER, anti-rattle	1	
119	NA	BARREL, inner cable	1	
121	ACH5112 €12.36	ABUTMENT, cable	1	
122	GHF331 €0.84	WASHER, locking	1	
123	GHF206 €1.32	NUT	1	
124	SH604041 €0.84	BOLT, coupling to balance pipe	2	
125	GHF331 €0.84	WASHER, locking	2	
126	GHF200 €0.96	NUT	2	
127	734-150	CABLE, front	1	
128	734-160	CABLE, centre	1	
129	734-170	CABLE, rear	1	
130	AUE34 €3.72	CABLE STOP, cable to carb.	3	

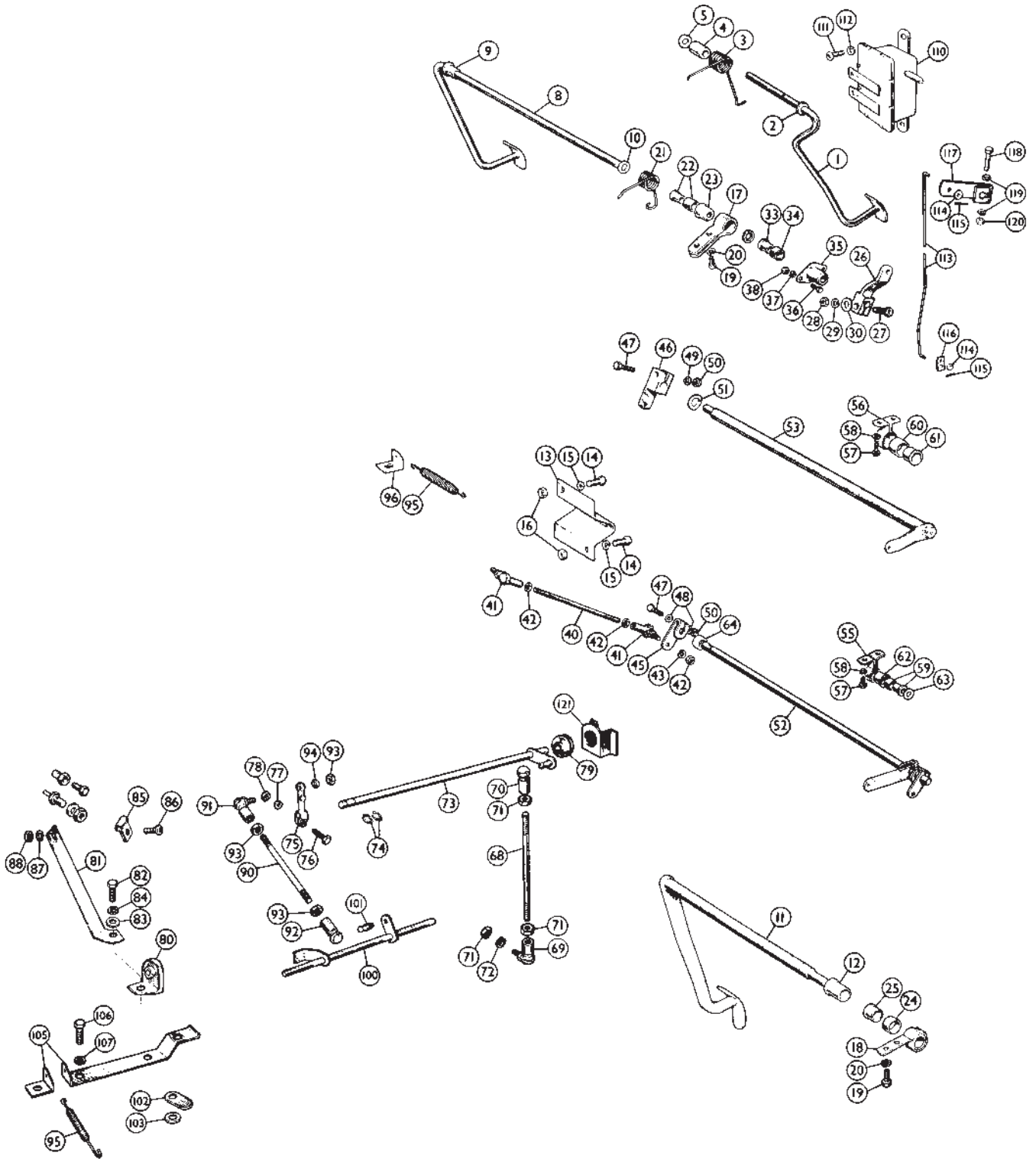

Ill.	Part Number	Price €ea.	Description	Req.	Details	
Engine Controls BJ7, BJ8						
1	021-823	€139.56	ACCELERATOR PEDAL ASSY	1	LHD models	
2	WP9	€2.04	WASHER, for rod	1		
3	021-924	€19.56	SPRING, pedal return	1		
4	NA		COLLAR, return spring location	1		
5	NA		WASHER, return spring location	1		
8	NA		ACCELERATOR PEDAL & SHAFT	1		
9	NA		COLLAR	1		
10	NA		WASHER	1		
11	NA		ACCELERATOR PEDAL & SHAFT	1		
12	NA		COLLAR	1		
13	NA		STOP, pedal	1		
14	NA		BOLT	2		
15	GHF331	€0.84	WASHER, locking	2		
16	GHF200	€0.96	NUT	2		
17	NA		SUPPORT, accelerator shaft	1		
18	NA		SUPPORT, accelerator shaft	1		BJ7 RHD models, BJ7 & BJ8 LHD models
19	SE604051	€0.84	SCREW	2		
20	GHF331	€0.84	WASHER, locking	2		
21	NA		SPRING, pedal return	1		
22	NA		BUSH & HOUSING ASSEMBLY	1		
23	NA		CUP, for bush	1		
24	NA		BUSH, pedal shaft	1		
25	NA		HOUSING, bush	1		
26	NA		LEVER, pedal shaft	1		
27	GHF103	€1.20	BOLT, lever to pedal shaft	1		
28	GHF201	€0.84	NUT	1		
29	GHF332	€0.84	WASHER, locking	2		
30	WP9	€2.04	WASHER	3		
33	NA		BUSH	1		
34	NA		HOUSING	1	see RH column for teflon replacement bushes	
35	021-951	€48.96	CUP, for bush	1		
36	NA		SCREW	2		
37	GHF331	€0.84	WASHER, locking	2		
38	GHF206	€1.32	NUT	2		
40	NA		CONTROL ROD, pedal shaft to relay lever	1		
41	ACB5311	€18.96	BALL JOINT, for rod	2		
42	GHF206	€1.32	NUT	4		
43	GHF331	€0.84	WASHER, locking	2		
45	NA		LEVER, accelerator relay shaft	1		
46	NA		LEVER, accelerator relay shaft	1		
47	SH605091	€1.80	BOLT	1		
48	GHF301	€0.60	WASHER, plain	2		
49	GHF332	€0.84	WASHER, locking	1		
50	GHF201	€0.84	NUT	1		
51	NA		WASHER, anti-rattle	1		
52	NA		RELAY SHAFT, accelerator	1		
53	NA		RELAY SHAFT, accelerator	1	BJ7 RHD models, BJ7 & BJ8 LHD models	
55	NA		MOUNTING BRACKET	2		
56	NA		MOUNTING BRACKET	2		
57	SH604051	€0.72	BOLT	4		
58	GHF331	€0.84	WASHER, locking	4		
59	NA		BUSH & HOUSING ASSEMBLY	2		
60	NA		BUSH, relay shaft	2		
61	NA		HOUSING	2		
62	NA		CUP, for bush	2		
63	WP9	€2.04	WASHER, plain	1		
64	NA		COLLAR	1		
68	NA		CONTROL ROD, relay shaft to accelerator	1		
69	ACB5311	€18.96	BALL JOINT, for rod	1		
70	ACB5311	€18.96	HOUSING, ball (discard ball end)	1		
71	GHF206	€1.32	NUT	3		
72	GHF331	€0.84	WASHER, locking	1		
73	NA		SPINDLE, accelerator	1		
74	NA		CIRCLIP, for spindle	2		
75	AUC4454	€45.24	LEVER, accelerator spindle	1		
76	NA		SCREW	1		
77	GHF331	€0.84	WASHER, locking	1		
78	GHF206	€1.32	NUT	1		
79	AHB8944	€8.52	BEARING, relay shaft, in dash	1		
80	371-610	€3.48	BRACKET, relay shaft, nylon	1		
81	372-065	€27.00	BRACKET, reinforcement	1		
82	GHF120	€0.72	BOLT	1		
83	GHF301	€0.60	WASHER, plain	1		
84	GHF332	€0.84	WASHER, locking	1		
85	CP105081	€1.92	CLIP, cable to front carb.	1		
86	NA		SCREW	1		
87	GHF331	€0.84	WASHER, locking	1		
88	GHF206	€1.32	NUT	1		
90	NA		CONTROL ROD, spindle lever to carb.	1		
91	ACB5311	€18.96	BALL JOINT, for rod	1		
92	NA		HOUSING, ball	1		
93	GHF206	€1.32	NUT	3		
94	GHF331	€0.84	WASHER, locking	1		
95	AEC2075	€2.64	SPRING, throttle return	2		

Ill.	Part Number	Price €ea.	Description	Req.	Details
96	372-245	€4.92	BRACKET	1	2-piece set
100	NA		SHAFT ASSEMBLY, carb. coupling	1	
	021-925	€73.68	SHAFT ASSEMBLY, carb. coupling	1	
101	NA		BALL END	1	
102	372-205	€9.36	BRACKET, throttle lever stop	1	
103	NA		WASHER, packing, .036	A/R	
	NA		WASHER, packing, .006	A/R	
105	372-215	€27.12	BRACKET, reinforcement	1	
106	GHF103	€1.20	BOLT, lever to pedal shaft	2	
107	GHF332	€0.84	WASHER, locking	2	
110	141-050	€122.64	THROTTLE SWITCH	1	
111	PMZ308	€0.72	SCREW, switch to dash	2	
112	GHF331	€0.84	WASHER, locking	2	
113	021-329	NA	LINK, throttle switch	1	
114	NA		WASHER, plain	2	
115	NA		SPLIT PIN	2	
116	NA		EYE, for link	1	
117	NA		LEVER, throttle switch, top	1	
118	53K129	€2.64	BOLT	1	
119	NA		WASHER, plain	2	
120	GHF206	€1.32	NUT	1	
121	021-926	€9.36	BRACKET, relay shaft bearing	1	

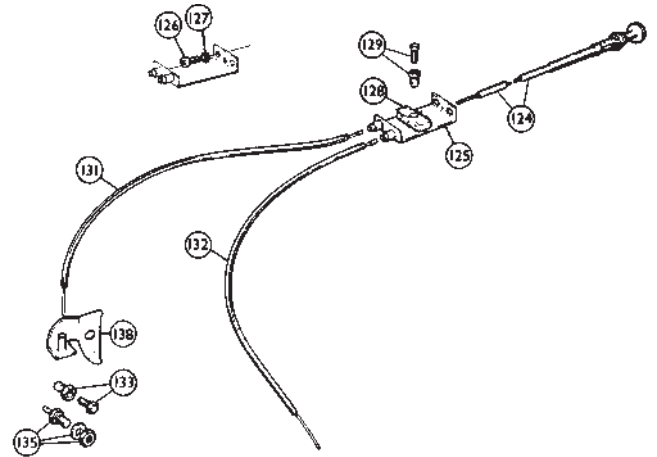

Choke Cables

124	NA		CHOKE CABLE*	1	BJ7
*Not available. Use AHB6021 as replacement.					
	AHB6021	€37.44	CHOKE CABLE	1	BJ8
125	372-225	€45.36	BODY, choke control	1	
126	PMZ307	€1.20	SCREW	2	
127	GHF331	€0.84	WASHER, locking	2	
128	372-235	€15.72	BLOCK, remote control cable	1	
129	24G1482K	€2.40	CABLE STOP, cable to block	1	
131	AHB6013	€6.96	CABLE, front carb.	1	
not plastic covered (the originals were)					
132	AHB6014	€6.96	CABLE, rear carb.	1	
133	AUE35	€11.88	CABLE STOP	2	BJ7
135	ACC5062K	€4.32	CABLE STOP	2	BJ8
138	372-135	€26.64	BRACKET, choke cable	2	

Lineup at the start of the Tulip Rally, Noordwijk, 4/22/64



The Morely brothers on the 1963 Alpine Rally

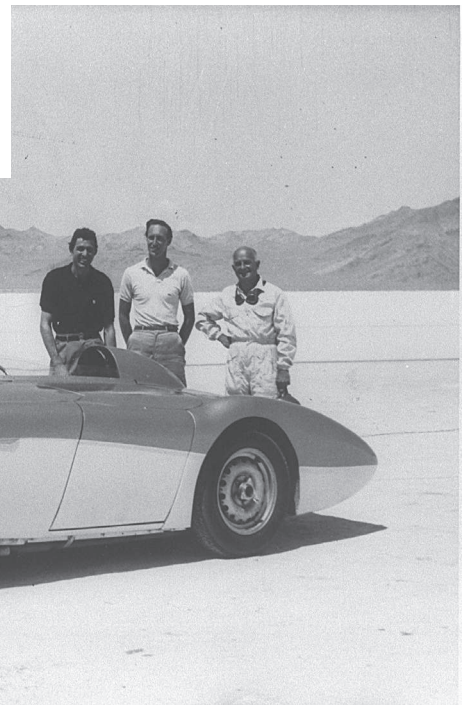

One of the several highly successful trips to the Bonneville Salt Flats by Austin-Healeys. This car set 24 hour records. Pictured from left to right are Carrol Shelby, Roy Jackson-Moore, and Donald Healey.

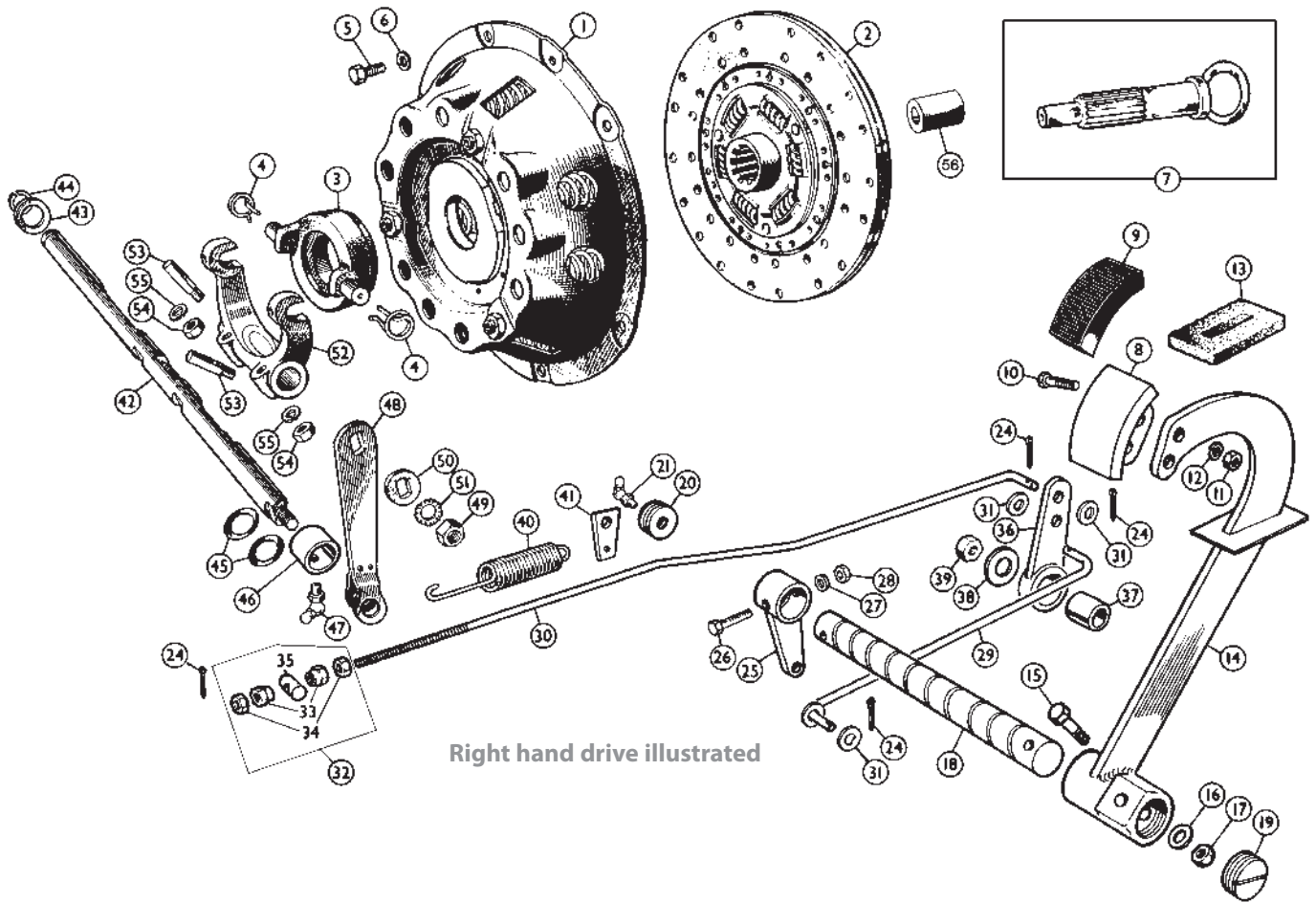

Right hand drive illustrated

ill. Part Number Price €ea. Description Req. Details

Clutch 100-4

ill.	Part Number	Price €ea.	Description	Req.	Details
1	GCC123BB	€220.44	PRESSURE PLATE, Borg & Beck	1	
2	27H3233	€148.68	CLUTCH PLATE	1	BN1
	GCP109AF	€108.24	CLUTCH PLATE, AP brand	1	BN2
3	GRB109	NA	RELEASE BEARING	1	BN1
	AEC3264	€41.16	RELEASE BEARING	1	BN2
4	7H3048	€3.72	SPRING CLIP, release bearing	2	
5	725-050	NA	BOLT, pressure plate to flywheel	6	
6	GHF332	€0.84	WASHER, locking	6	
7	021-660	NA	CLUTCH ALIGNMENT TOOL	1	BN1
	021-670	€9.48	CLUTCH ALIGNMENT TOOL	1	BN2
8	NA	NA	PEDAL PAD, clutch	1	
9	1B8751	€2.76	PEDAL PAD, rubber	1	
10	NA	NA	BOLT	2	
11	GHF200	€0.96	NUT	2	
12	GHF331	€0.84	WASHER, locking	2	
13	682-120	€14.64	DRAUGHT EXCLUDER, pedal	1	
14	682-121	€355.20	LEVER, clutch pedal	1	LHD
			LEVER, clutch pedal	1	RHD
15	NA	NA	BOLT, pedal to shaft	1	
16	GHF301	€0.60	WASHER, plain	1	
17	LNZ105	€1.68	NUT	1	
18	021-701	€106.08	SHAFT, clutch & brake pedal	1	LHD
	021-723	€101.52	SHAFT, clutch & brake pedal	1	RHD
19	725-055	NA	PLUG	1	
20	725-060	NA	PLUG, for grease nipple	1	
21	LN30041	€2.16	NIPPLE, grease	1	
		NA	SLEEVE, spacing	1	RHD
24	GHF502	€1.08	SPLIT PIN	4	
25	1B8752	€90.60	LEVER, clutch con rod	1	
26	BH605141	€2.52	BOLT, lever to shaft	1	
27	GHF301	€0.60	WASHER, plain	1	
28	LNZ105	€1.68	NUT	1	
	502-228	€115.44	CON ROD SET	1	
29	NA	NA	CON ROD, clutch, non-adjustable	1	
30	NA	NA	CON ROD, clutch, adjustable	1	
31	GHF301	€0.60	WASHER, plain	3	
32	596-198	€21.36	TRUNNION & NUT KIT	1	
33	596-190	NA	NUT, adjusting	2	
34	NT605041	€0.84	NUT, locking	2	
35	596-200	NA	TRUNNION	1	
36	596-015	€88.56	RELAY LEVER, clutch	1	
37	330-450	NA	BUSH (in lever)	1	
38	NA	NA	WASHER	1	

ill. Part Number Price €ea. Description Req. Details

39	GHF223	€1.56	LOCKNUT	1	
40	1G5999	€4.08	SPRING, clutch return	1	
41	586-085	€12.96	ANCHOR	1	
42	021-702	NA	SHAFT, clutch operating	1	BN1, LHD
	021-705	€164.88	SHAFT, clutch operating	1	BN2, LHD
		NA	SHAFT, clutch operating	1	BN1, RHD
		NA	SHAFT, clutch operating	1	BN2, RHD
43	NA	NA	WASHER, plain	1	
44	NA	NA	CIRCLIP	1	
45	330-461	€2.52	SHIM, .010	A/R	
		NA	SHIM, .015	A/R	
46	330-460	€17.16	BUSH, for shaft in gearbox casing	4	
47	021-704	NA	NIPPLE, grease	2	
48	596-240	€38.28	LEVER, for operating shaft	1	
49	GHF203	€0.72	NUT, UNF	1	LHD
		NA	NUT, BSF	1	RHD
50	596-125	€11.16	WASHER, slotted	1	
51	NA	NA	WASHER, shakeproof	1	
52	NA	NA	FORK, clutch	1	BN1
		NA	FORK, clutch	1	BN2
53	330-462	€1.92	COTTER, UNF threads, 28 tpi	2	
54	GHF200	€0.96	NUT for cotters, UNF threads, 28 tpi	2	
	AJD8104	€1.08	NUT for cotters, BSF threads, 26 tpi	2	
55	GHF331	€0.84	WASHER, locking	2	
56	1K369	€5.16	SPIGOT BUSHING	1	

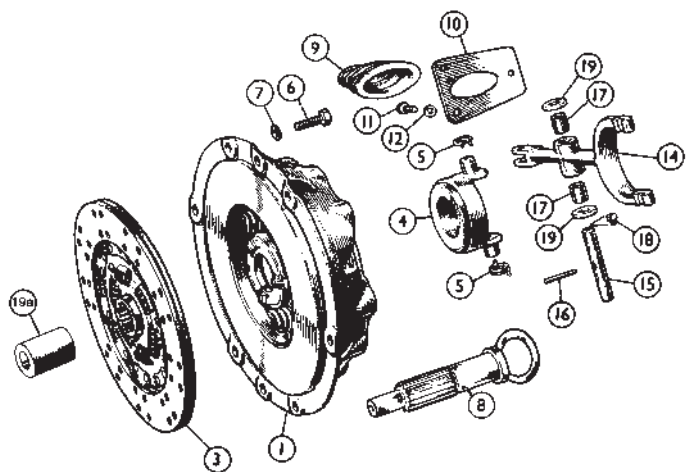
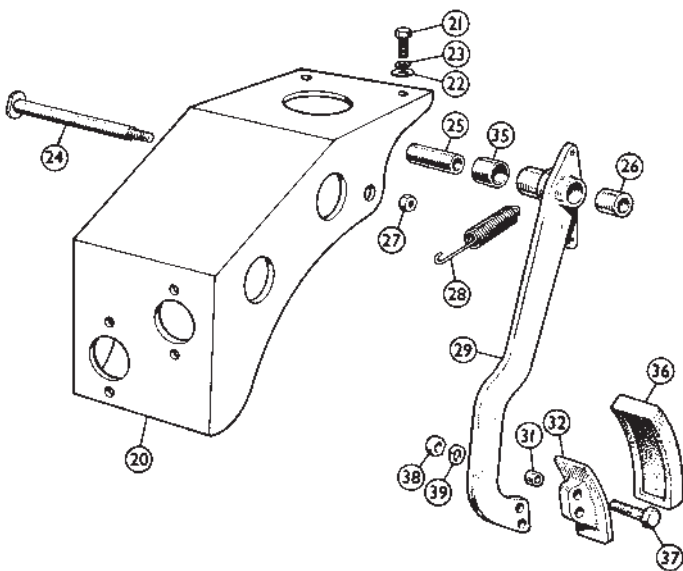
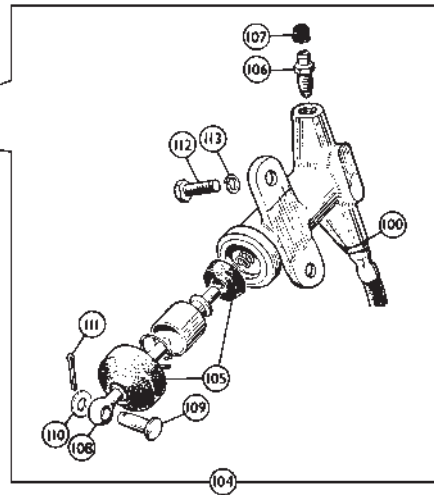
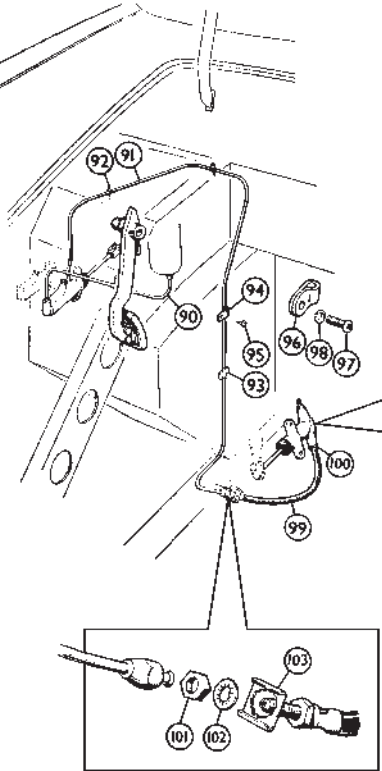
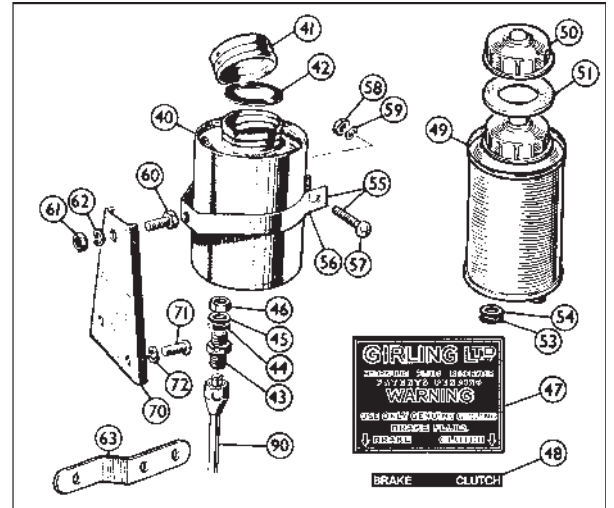
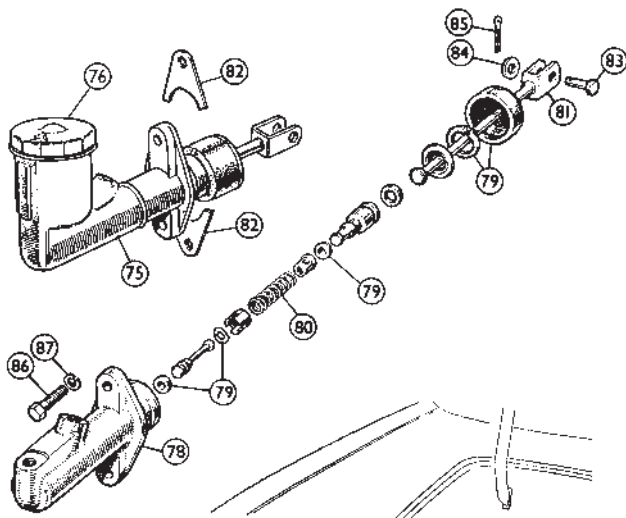

ill.	Part Number	Price €ea.	Description	Req.	Details	ill.	Part Number	Price €ea.	Description	Req.	Details
Clutch 100-6, 3000											
1	GCC123BB	€220.44	PRESSURE PLATE, 9" dia	1	BN4, BN6	63	596-085	€12.48	BRACKET, supply tank	1	LHD models (not tri-carb)
	GCC116BB	€256.80	PRESSURE PLATE, 10" dia	1	BN7, BT7, BJ7 to 29F-H4878	70	582-965	€13.08	BRACKET, supply tank	1	RHD models
	GCC112	€193.56	PRESSURE PLATE, 9-1/2" dia. AP brand	1	BJ7 from 29F-H4879, BJ8	71	SH604031	€2.28	BOLT	2	
Note: 9" & 10" units are lever type, 9-1/2" unit is diaphragm spring type.											
3	GCP109AF	€108.24	CLUTCH PLATE	1	BN4, BN6	72	GHF331	€0.84	WASHER, locking	2	BN4 to C.E.48862
	GCP118	€129.72	CLUTCH PLATE, AP brand	1	BN7, BT7, BJ7 to 29F-H4878	75	11B5281	€99.72	CLUTCH MASTER CYLINDER	1	
	502-505	€93.96	CLUTCH PLATE	1	BJ7 from 29F-H4879, BJ8	76	500201	€10.80	CAP, bright finish	1	BN4 from C.E.48863, BN6, BN7, BT7, BJ7, BJ8
4	AEC3264	€41.16	RELEASE BEARING	1	BN4, BN6	77	500201Z	€7.68	CAP, black painted, replacement	1	
	GRB104	€27.72	RELEASE BEARING	1	BN7, BT7, BJ7 to 29F-H4878	78	11B5510	€77.88	CLUTCH MASTER CYLINDER	1	
	GRB105	€71.16	RELEASE BEARING	1	BJ7 from 29F-H4879, BJ8	79	GRK1029	€12.72	REPAIR KIT	1	
	GRB105Z	€29.76	RELEASE BEARING, aftermarket	1	BJ7 from 29F-H4879, BJ8	80	80	NA	SPRING	1	
5	7H3048	€3.72	RETAINER, release bearing	2		81	513-322	€16.80	PUSHROD	1	
6	SH605071	€1.20	BOLT, pressure plate to flywheel	6	BN4, BN6	82	021-488	€3.24	SHIM	A/R	
	SH606071	€0.84	BOLT, pressure plate to flywheel	6	BN7, BT7, BJ7 to 29F-H4878	83	CLZ513	€1.32	CLEVIS PIN	1	
	GHF120	€0.72	BOLT, pressure plate to flywheel	6	BJ7 from 29F-H4879, BJ8	84	GHF301	€0.60	WASHER, plain	1	
7	GHF332	€0.84	WASHER, locking	6	BN4, BN6	85	GHF502	€1.08	SPLIT PIN	1	
	GHF333	€0.72	WASHER, locking	6	BN7, BT7, BJ7 to 29F-H4878	86	GHF103	€1.20	BOLT, cylinder to bracket	2	
	GHF332	€0.84	WASHER, locking	6	BJ7 from 29F-H4879, BJ8	87	GHF332	€0.84	WASHER, locking	2	
8	021-670	€9.48	CLUTCH ALIGNMENT TOOL	1		90	581-520	€36.96	PIPE, cylinder to tank, LHD	1	BN4 from C.E.48863, BN6, BN7, BT7, BJ7, BJ8
9	AEC3106	€6.12	GAITER, clutch fork	1		91	021-932	€37.08	PIPE, cylinder to hose	1	
10	021-928	€13.44	COVER PLATE	1			NA	PIPE, cylinder to hose	1	RHD models	
11	53K1435	€2.40	SCREW	3		92	92	NA	CLIP, pipe to dash	2	LHD models
12	GHF331	€0.84	WASHER, locking	3		93	1G9529	€1.08	CLIP, pipe to pedal box	1	BN7, BT7, BJ7, BJ8
14	725-080	NA	FORK, clutch	1	(incl. #15, 16, 17)	94	PCR307	€2.16	CLIP, pipe to pedal box	1	
	330-405	€118.44	REPAIR KIT, clutch fork	1		95	95	NA	SCREW	1	RHD models
15	021-929	€21.24	SHAFT, clutch fork	1		96	PCR307	€2.16	CLIP	1	
16	725-085	NA	PIN, tapered	2		97	97	NA	SCREW	1	
17	330-470	€2.52	BUSH	2		98	GHF331	€0.84	WASHER, locking	1	
18	NA	NA	SCREW, clutch fork shaft (upper end)	1		99	GBH415	€19.20	HOSE, clutch, TRW/Girling	1	
19	725-090	NA	THRUST WASHER	2			GBH415Z	€10.08	HOSE, clutch, aftermarket	1	
19a	1K369	€5.16	SPIGOT BUSHING	1			TT3041A	€35.88	HOSE, clutch, stainless steel braided	1	
Pedal and Pedal box											
20	NA	NA	BRACKET, clutch & brake pedal	1		100	233220A	€1.68	WASHER, copper	1	
21	SH605051	€1.80	BOLT, bracket to pedal box	2		101	NT606041	€1.08	NUT	1	
22	PWZ205	€0.72	WASHER, plain	2		102	GHF323	€0.96	WASHER, shakeproof	1	
23	GHF332	€0.84	WASHER, locking	2		103	1G9198	€4.44	LOCKPLATE	1	
24	021-486	NA	SHAFT, clutch & brake pedal	1		104	GSY111	€49.08	SLAVE CYLINDER, Classic Gold	1	
25	725-095	NA	SLEEVE, for shaft	2		105	GRK4017	€11.88	REPAIR KIT, slave cylinder	1	
26	726-000	NA	SPACER	1		106	3H2428	€2.04	BLEED SCREW	1	
27	GHF222	€1.08	NUT	1		107	SMP100030	€1.68	DUST CAP, bleed screw	1	
28	329-075	€9.96	SPRING, clutch pedal return	1		108	596-220	€10.20	PUSH ROD	1	
29	NA	NA	LEVER, clutch pedal	1	BN4, BN6, BN7 to (c)16038, BT7 to (c)15880	109	CLZ515	€2.40	CLEVIS PIN	1	
	NA	NA	LEVER, clutch pedal	1	BN7 from (c)16039 thru BJ8	110	GHF301	€0.60	WASHER, plain	1	
31	NA	NA	SPACER	2	BN4, BN6, BN7 to (c)16038, BT7 to (c)15880	111	111	NA	SPLIT PIN	1	
32	NA	NA	PEDAL PAD, clutch	1	BN4, BN6, BN7 to (c)16038, BT7 to (c)15880	112	GHF105	€0.84	BOLT	2	
	NA	NA	PEDAL PAD, clutch	1	BN7 from (c)16039, BT7 from (c)15881	113	GHF333	€0.72	WASHER, locking	2	
	NA	NA	PEDAL PAD, clutch	1	BJ7, BJ8						
35	1G9310	NA	BUSH	2							
36	1B8751	€2.76	PEDAL PAD, rubber	1							
37	BH604111	€1.68	BOLT	2							
38	GHF200	€0.96	NUT	2							
39	GHF331	€0.84	WASHER, locking	2							
Hydraulics											
40	114530	€74.76	RESERVOIR, dual outlet (incl. decal no. 47)	1	BN4 from C.E.48863, BN6, BN7, BT7 thru early 1959						
	ACB5856	NA	RESERVOIR, dual outlet (incl. decal 582-983)	1	BN7, BT7 from mid 1959, BJ7, BJ8						
41	596-211	€21.48	CAP, filler, knurled edge	1	thru early 1959						
	596-212	€21.48	CAP, filler, faceted edge	1	from mid 1959						
42	106095	€1.44	SEAL, filler cap. orig. type	1							
	582-505	€9.00	SEAL, splash-proof (repl.) (incl. with 582-981, ACB5856)	1							
43	NA	NA	ADAPTOR	2							
44	3H693	€1.56	WASHER, copper	2							
	582-987	€2.52	WASHER, stainless with Viton insert (replaces washers no. 44 & 45)	4	(incl. w/tanks above)						
45	NA	NA	WASHER	2							
46	NA	NA	NUT	2							
47	216-496	€4.20	DECAL, "Girling, Ltd.,"	1	thru early 1959						
48	582-983	€2.76	DECAL, "Brake" "Clutch"	1	from mid 1959						
49	582-974	NA	TANK, single outlet	1							
50	596-212	€21.48	CAP, filler	1	BJ8 from (c)44930, France & Benelux Countries						
51	106095	€1.44	SEAL, filler cap	1							
	582-505	€9.00	SEAL, splash-proof (repl.)	1							
53	NA	NA	GASKET, adaptor	1							
54	GHF304	€0.72	WASHER, plain	1							
55	582-985	€9.12	CLIP ASSEMBLY, incl. hardware	1							
56	NA	NA	CLIP	1							
57	PMZ314	€0.72	SCREW	1							
58	GHF206	€1.32	NUT	1	BN4 from C.E.48863, BN6, BN7, BT7, BJ7, BJ8						
59	GHF331	€0.84	WASHER, locking	1							
60	SH604041	€0.84	BOLT	1							
61	GHF200	€0.96	NUT	1							
62	GHF331	€0.84	WASHER, locking	1							

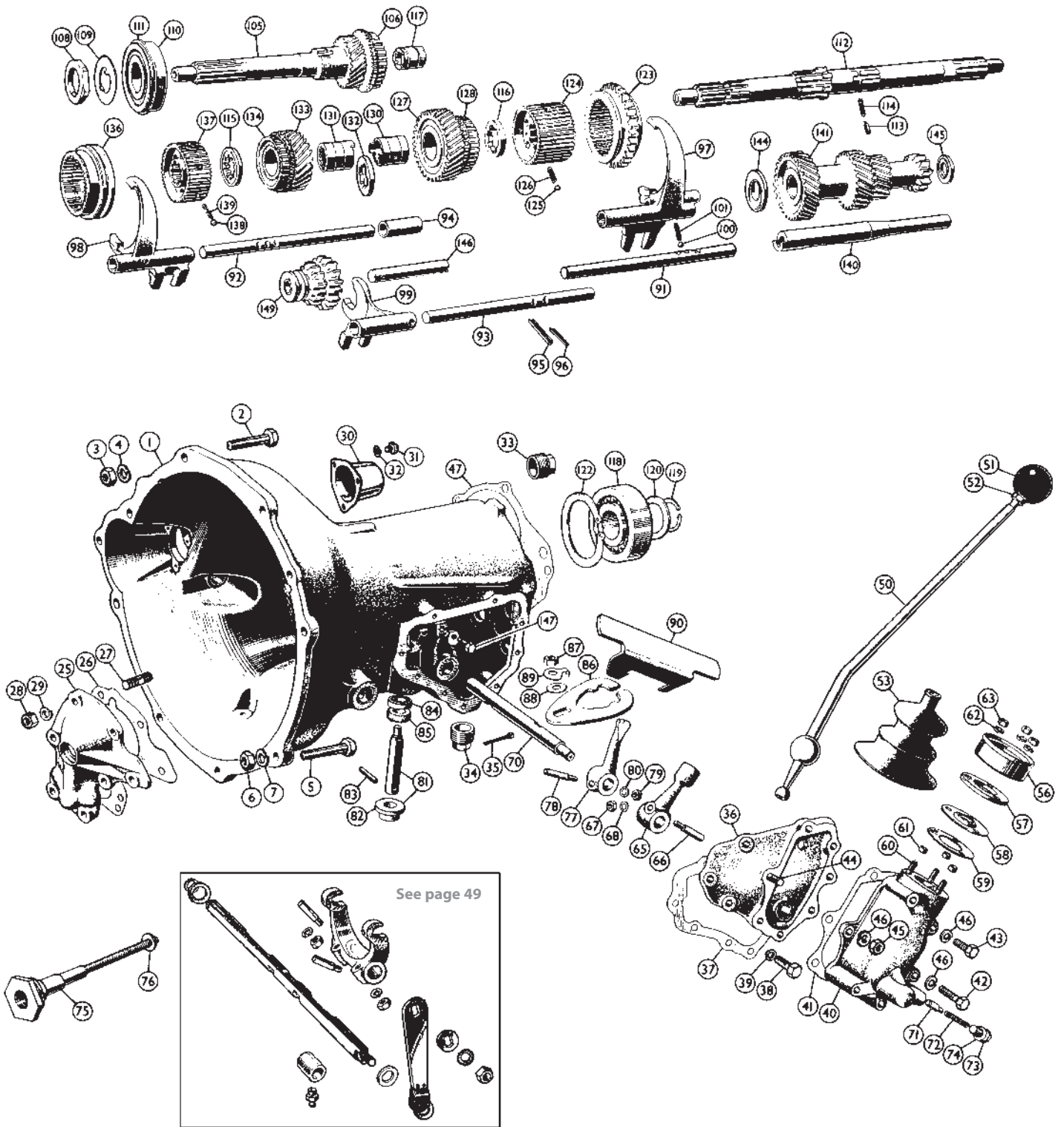

ill.	Part Number	Price €ea.	Description	Req.	Details
Gearbox 3 speed BN1					
	021-054	€18.72	GASKET SET (includes 1 ea. of ill. nos. 26, 37, 41 & 47)	1	
1		NA	CASING, gearbox	1	
2		NA	DOWEL BOLT, to mounting plate	2	
3	AJD8106Z	€0.96	NUT	2	
4	GHF333	€0.72	WASHER, locking	2	
5		NA	BOLT, to mounting plate	6	
6	AJD8106Z	€0.96	NUT	6	
7	GHF333	€0.72	WASHER, locking	6	
25		NA	COVER, front	1	
26		NA	GASKET, front cover	1	in gasket set
27		NA	STUD, in casing	7	
28	AJD8105Z	€0.72	NUT	7	
29	GHF332	€0.84	WASHER, locking	7	
30	1B3346	NA	COVER, starter pinion	1	
31		NA	SCREW	3	
32	GHF331	€0.84	WASHER, locking	3	
33	2K5830	€12.24	PLUG, oil filler	1	
34	2K5830	€12.24	PLUG, oil drain	1	
	2K5830X	€28.08	PLUG, oil drain, magnetic	1	(optional)
35		NA	SPLIT PIN, clutch pin drain hole	1	
36		NA	SIDE COVER	1	
37		NA	GASKET, side cover	1	in gasket set
38	320-370	€4.20	BOLT	3	
39	GHF332	€0.84	WASHER, locking	3	
40		NA	BODY, shifter control box	1	
41		NA	GASKET, body to side cover	1	in gasket set
42		NA	BOLT, long	1	
43		NA	BOLT, short	5	
44		NA	STUD	1	
45	AJD8105Z	€0.72	NUT	1	
46	GHF332	€0.84	WASHER, locking	7	
47		NA	GASKET, casing to o/d adaptor plate	1	in gasket set
50		NA	GEAR LEVER	1	LHD
		NA	GEAR LEVER	1	RHD
51	021-398	€75.96	KNOB, gear lever	1	
52		NA	LOCKNUT	1	
53	2F3087	€29.76	GAITER, gear lever	1	
		NA	SCREW, locating	1	
		NA	LOCKWASHER	1	
		NA	COVER, gear lever	1	
56		€7.80	PAD, gear lever packing, rubber	1	thick
57	848-770	€7.80	PAD, gear lever packing, rubber	1	thin
58		NA	SEAT, gear lever	1	
59	848-765	€6.72	WASHER, sealing, rubber	1	
60	031-450	NA	STUD	3	
61	848-775	€3.72	SPACER	3	
62	GHF331	€0.84	WASHER, locking	3	
63	GHF200	€0.96	NUT	3	
65		NA	LEVER, shifter socket	1	
66		NA	COTTER, lever to cross shaft	1	
67	AJD8104	€1.08	NUT	1	
68		NA	WASHER, shakeproof	1	
70		NA	CROSS SHAFT, shifter	1	
71	848-780	NA	PLUNGER	1	
72	22A75	€2.76	SPRING	1	
73	6K643	NA	PLUG	1	
74	2K4956	€0.84	WASHER, fibre	1	
75		NA	ADAPTOR ASSY, for O/D limiting switch	1	top & 2nd gear
76		NA	WASHER, fibre	1	
77		NA	LEVER, operating	1	
78		NA	COTTER	1	
79	AJD8104	€1.08	NUT	1	
80		NA	WASHER, shakeproof	1	
81		NA	SHAFT, interlocking, with collar	1	
82		NA	COLLAR	1	
83		NA	PIN, tapered	1	
84	848-800	€4.32	OIL SEAL	1	
85	848-810	NA	RING, felt	1	
86		NA	ARM, selector	1	
87		NA	NUT	1	
88		NA	WASHER	1	
89		NA	TABWASHER	1	
90		NA	GATE, shifter	1	
91		NA	ROD, 1st & 2nd speed fork	1	
92		NA	ROD, 3rd & 4th speed fork	1	
93		NA	ROD, reverse fork	1	
94		NA	SPACER	1	
95		NA	LOCATING STRIP, long	1	
96		NA	LOCATING STRIP, short	1	
97		NA	FORK, 1st & 2nd speed	1	
98		NA	FORK, 3rd & 4th speed	1	
99		NA	FORK, reverse	1	
100	BLS109	€1.08	BALL, 9/32	3	
101		NA	SPRING, for ball	3	
105	031-245	NA	SHAFT, 1st motion	1	to (g)5145
	031-246	NA	SHAFT, 1st motion	1	from (g)5146
106	031-247	€332.40	SYNCHRO CONE	1	
108		NA	NUT	1	
109	1A3717	€4.44	LOCKWASHER	1	
110	128-200	€45.24	BEARING, 1st motion shaft	1	
111		NA	RING, spring	1	
112		NA	MAINSHAFT	1	to (c)140204
		NA	MAINSHAFT	1	from (c)140205

ill.	Part Number	Price €ea.	Description	Req.	Details
113	1G3268	NA	PEG	1	
114	2K8960	NA	SPRING	1	
115	11G3127	€7.80	THRUST WASHER, front, (.1565/.1575)	1	
	11G3128	€26.04	THRUST WASHER, front, (.1585/.1595)	1	
	11G3129	€26.04	THRUST WASHER, front, (.1605/.1615)	1	
116		NA	THRUST WASHER, rear	1	
117	031-231	NA	BUSH, 1st motion shaft	1	
118	GHB158	€18.84	BEARING, mainshaft	1	
119	058956	€1.80	CIRCLIP	1	
120		NA	SPACER	1	to (c)140204
		NA	SPACER	1	from (c)140205
		NA	SHIM	AR	
122		NA	CIRCLIP	1	
123	031-332	NA	FIRST GEAR	1	
124	031-334	NA	SYNCHRONIZER, 2nd speed	1	
125	BLS108	€3.24	BALL, 1/4"	6	
126		NA	SPRING	6	
127	031-333	NA	GEAR, 2nd, with cone & adaptor	1	
128	031-247	€332.40	SYNCHRO CONE	1	
130	031-335	NA	BUSH, 2nd gear	1	
131	11G3029	NA	BUSH, 3rd speed mainshaft gear	1	
132	031-336	NA	RING, interlocking	1	
133	031-248	NA	GEAR, 3rd, with cone & adaptor	1	to (g)5145
	031-337	NA	GEAR, 3rd, with cone & adaptor	1	from (g)5146
134	031-247	€332.40	SYNCHRO CONE	1	
136	031-249	NA	STRIKING DOG, 3rd & 4th	1	
137	031-338	NA	SYNCHRONIZER, 3rd & 4th	1	
138	BLS108	€3.24	BALL, 1/4"	3	
139		NA	SPRING	3	
140	031-331	€117.60	LAYSHAFT	1	
141		NA	LAYGEAR, with bushes	1	to (g)5145
		NA	LAYGEAR, with bushes	1	from (g)5146
		NA	BUSH, front	1	
		NA	BUSH, rear	1	
144		NA	THRUST WASHER, front	1	
145		NA	THRUST WASHER, rear, (.1565/.1575)	1	
		NA	THRUST WASHER, rear, (.1585/.1595)	1	
		NA	THRUST WASHER, rear, (.1605/.1615)	1	
		NA	THRUST WASHER, rear, (.163/.164)	1	
146		NA	SHAFT, reverse gear	1	
147		NA	SCREW	1	
	AEC340	€2.76	TAB WASHER	1	
149	848-855	NA	GEAR, reverse	1	
		NA	BUSH	1	

Note: Must be machined to fit, see workshop manual (instructions included).

Note: for gearbox mountings, please see page 64

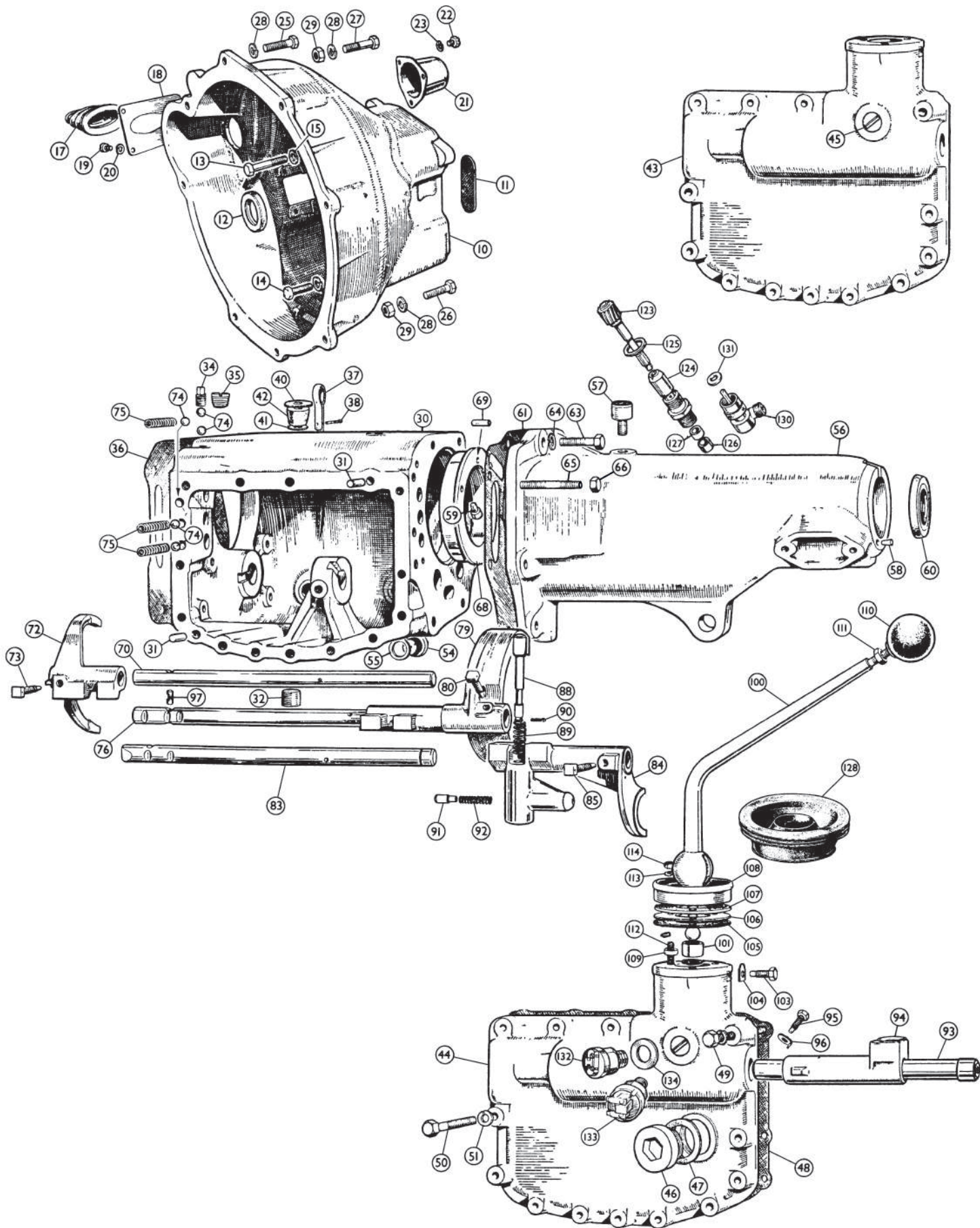

ill.	Part Number	Price €ea.	Description	Req.	Details	ill.	Part Number	Price €ea.	Description	Req.	Details
External gearbox 4 Speed offset gear change						88	848-820		NA PLUNGER, reverse selector	1	
			NA HOUSING, clutch, with bushes	1		89	329-105	€6.84	SPRING, plunger	1	
	330-460	€17.16	BUSH, for operating shaft (in case)	4		90	GHF502	€1.08	SPLIT PIN	1	
			NA CASING, gearbox	1	BN2 (not illustrated)	91	848-780		NA PLUNGER, detent	1	
	10K7089	€4.80	SEAL, oil	1		92	22A75	€2.76	SPRING, detent plunger	1	
			NA BOLT, housing to gearbox	8		93			NA SHAFT, control	1	
	GHF332	€0.84	WASHER, locking	8		94			NA LEVER, control	1	
10			NA HOUSING, clutch	1	BN4, BN6	95	1G3581		NA BOLT, shaft locking	1	
			NA HOUSING, clutch	1	BN7, BT7	96	AEC340	€2.76	LOCK TAB	1	
11	031-339		NA PAD, buffer	1	BN4, BN6, BN7, BT7	97			NA PIN, interlocking	1	
12	10K7089	€4.80	SEAL, oil	1	BN7, BT7	100	848-985	€235.80	GEAR LEVER	1	BN2 to C.E.228486
							848-985	€235.80	GEAR LEVER	1	BN2 from C.E.228487, BN4, BN6, BN7 & BT7 to (e)29D-H20597
											BN7 & BT7 from (e)29D-H20598
						101			NA BUSH, lever (use 461-110 below)	1	BN2
							AEC3520	€19.68	BUSH, lever, stock type	1	BN4, BN6, BN7, BT7
							22H15	€5.40	BUSH, lever, nylon replacement	1	all except BJ8
							1G3709		NA CIRCLIP, bush	1	
						103			NA BOLT, lever locating	1	
						104			NA WASHER, tab, screw	1	
						105	848-765	€6.72	WASHER, sealing, shift lever	1	(thin)
						106			NA SEAT, gear lever	1	
						107	848-770	€7.80	PAD, gear lever packing	1	(thick)
						108			NA COVER, gear lever	1	
						109	848-775	€3.72	SPACER, cover	3	
						110	1B3736	€9.96	KNOB, gear lever	1	
						111	54K1723	€1.80	LOCKNUT, knob (chrome)	1	
						112	031-450		NA STUD, gear lever cover	3	
						113	GHF331	€0.84	WASHER, locking	3	
						114	GHF200	€0.96	NUT, stud	3	
						123			NA PINION, speedometer	1	BN4, BN6 non o/d
							848-920		NA PINION, speedometer	1	BN7 & BT7 non o/d
						124			NA BEARING, pinion	1	
						125	324-215		NA WASHER, bearing	1	BN4, BN6, BN7, BT7 non o/d
						126			NA COLLAR, pinion distance	1	
						127	NKC105A	€5.76	SEAL, oil, pinion	1	
						128	14B6877	€10.20	GAITER, gear lever	1	BN2, BN4, BN6, BN7, BT7
						130	768-020	€161.52	ANGLE DRIVE, speedometer	1	BN2
							120694	€63.00	ANGLE DRIVE, speedometer	1	BN4, BN6, BN7, BT7
						131	3H550	€1.20	WASHER, adaptor	1	
						132			NA SWITCH, overdrive, on gearbox	1	BN1, BN2, BN4, BN6
						133	LU39890		NA SWITCH, overdrive, on gearbox	1	BN7, BT7
							BAU1074Z	€14.16	SWITCH, overdrive, on gearbox	1	
						134	1B3664	€0.96	WASHER, fibre	A/R	
13	BH605181	€1.92	BOLT, housing to gearbox, 2-1/4"	1							
14	SH605091	€1.80	BOLT, housing to gearbox, 1-1/8"	7							
15	GHF332	€0.84	WASHER, locking	8							
17	AEC3106	€6.12	GAITER, clutch fork	1							
18	021-928	€13.44	COVER PLATE	1							
19	53K1435	€2.40	SCREW, plate	3	BN4, BN6, BN7, BT7						
20	GHF331	€0.84	WASHER, locking	3							
21	1B3346		NA COVER, starter end	1							
22			NA SCREW, cover to housing	1							
23	GHF331	€0.84	WASHER, locking	3							
25			NA BOLT, clutch housing to rear plate	5	BN2						
			NA BOLT, clutch housing to rear plate, 1-1/2"	1	BN4, BN6, BN7, BT7						
26			NA BOLT, clutch housing to rear plate, 1-3/8"	4							
27			NA DOWEL BOLT, clutch housing to rear plate	2	BN2						
	324-022	€21.60	DOWEL BOLT, clutch housing to rear plate	2	BN4, BN6, BN7, BT7						
28	GHF333	€0.72	WASHER, locking	7							
29	GHF202	€0.72	NUT	6							
			NA CASE, gearbox	1	BN2, BN4, BN6						
			NA CASE, gearbox	1	BN7, BT7						
31			NA DOWEL, side cover	2							
32	6K499	€4.08	PLUG, oil drain	1							
			NA PLUG, interlock ball hole	1	BN2, BN4, BN6						
34			NA PLUG, interlock ball hole	1	BN7, BT7						
35			NA PLUG, taper	1							
	MM021-053	€21.00	GASKET SET	1	includes ill. 36, 48 & 61						
36			NA GASKET, case to clutch housing	1	in gasket set						
37			NA DIP STICK, oil level	1							
38	PS103121	€1.92	SPLIT PIN	1							
40			NA WASHER, large	1							
41			NA WASHER, small	1							
42			NA WASHER, felt	1							
43			NA COVER, side	1	BN2, BN4, BN6 to (g)2856 non o/d & to (g)9273 o/d						
44			NA COVER, side	1	BN6 from (g)2857 non o/d & from (g)9274 o/d, BN7 & BT7 to (e)29E-H2245						
45			NA PLUG, small, side cover non o/d	1	BN2, BN4, BN6, BN7, BT7						
46			NA PLUG, large, side cover	1	BN6 from (g)2857 non o/d & from (g)9274 o/d, BN7, BT7						
47	6K432	€5.16	WASHER for plug	1	included in gasket set						
48			NA GASKET, cover to gearbox	1							
49	BH605221	€1.68	BOLT, cover to gearbox, 2-3/4"	1							
50	GHF104	€1.20	BOLT, cover to gearbox, 1-1/2"	12							
51	GHF332	€0.84	WASHER, locking	13							
54			NA CAP, control shaft boss	2	BN2						
			NA CAP, control shaft boss	2	BN4, BN6, BN7, BT7						
55	6K432	€5.16	WASHER, cap	2							
56			NA CASING, gearbox extension	1							
57	21H6060	€6.12	BREATHER	1							
58			NA PLUG, taper	1							
59	1A3073		NA THRUST WASHER	1	BN4, BN6, BN7, BT7 non o/d						
60	88G320	€5.64	SEAL, oil	1							
61			NA GASKET, casing or overdrive to gearbox	1							
63	BH605101	€2.16	BOLT, casing to gearbox	8							
64	GHF332	€0.84	WASHER, locking	8							
65			NA STUD, casing to gearbox	8	BN2, BN4, BN6, BN7, BT7 o/d						
66	GHF201	€0.84	NUT	8							
68			NA HOUSING, bearing	1	BN2 to C.E.230489						
			NA HOUSING, bearing	1	BN2 from C.E.230490, BN4, BN6						
			NA HOUSING, bearing	1	BN7, BT7						
69	1G3530		NA PEG, locating	1	BN2 to C.E.230489						
			NA PEG, locating	1	BN2 from C.E.230490, BN4, BN6, BN7, BT7						
70			NA SHAFT, 3rd and 4th selector	1	BN2						
			NA SHAFT, 3rd and 4th selector	1	BN4, BN6, BN7, BT7						
72	031-257	€210.48	FORK, striking, 3rd and 4th	1							
73	848-065	€13.68	SCREW, fork to shaft	1							
74	BLS110	€0.84	BALL, selector shaft	5							
75	329-040	€4.32	SPRING, ball	3							
76			NA SHAFT, 1st and 2nd selector	1	BN2						
77	031-340	€111.24	SHAFT, 1st and 2nd selector	1							
			NA PIN, shaft interlocking	1	BN4, BN6, BN7, BT7						
			NA RIVET, interlocking pin	1							
79			NA FORK, striking, 1st and 2nd	1							
80	848-065	€13.68	SCREW, fork to shaft	1							
83			NA SHAFT, reverse selector	1	BN2						
			NA SHAFT, reverse selector	1	BN4, BN6, BN7, BT7						
84			NA FORK, striking, reverse	1							
85	848-065	€13.68	SCREW, fork to shaft	1							

from Nov., 1961
E29E/2246
C BT7/15881

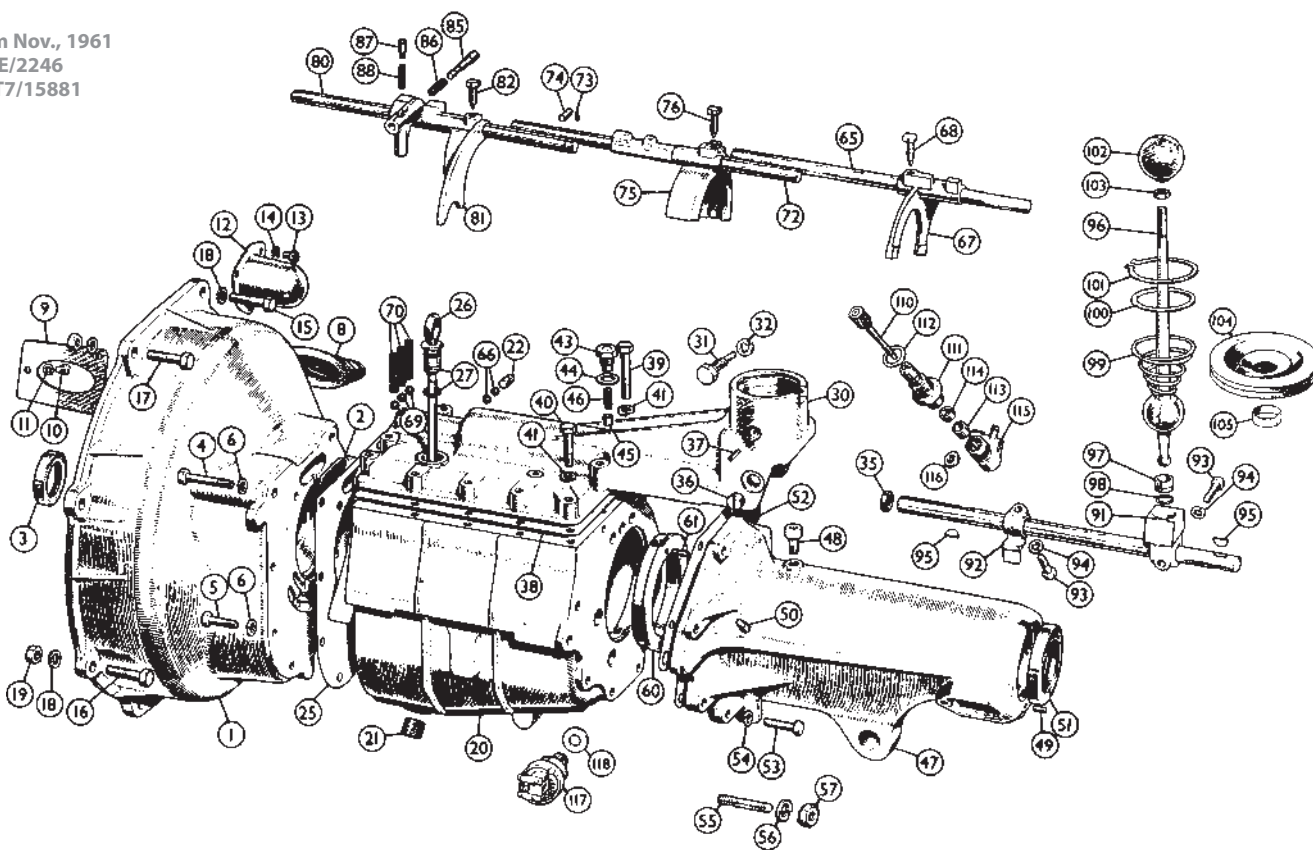

ill.	Part Number	Price €ea.	Description	Req.	Details	ill.	Part Number	Price €ea.	Description	Req.	Details
External gearbox 4 Speed centre gear change						97	AEC3520	€19.68	BUSH ASSEMBLY, lever, bronze (includes circlip)	1	BN7, BT7, BJ7
	NA		GEARBOX ASSEMBLY, standard	1	BN7, BT7, BJ7		031-259	€5.16	BUSH, lever, nylon	1	BJ8
	NA		GEARBOX ASSEMBLY, standard	1	BJ8	98	1G3709	NA	CIRCLIP, bush	1	BN7, BT7, BJ7
	NA		GEARBOX ASSEMBLY, overdrive	1	BN7, BT7, BJ7	99	031-330	€9.96	SPRING, ball end retaining	1	
	NA		GEARBOX ASSEMBLY, overdrive	1	BJ8	100	848-955	€5.64	WASHER	1	
1	NA		HOUSING, clutch	1	BN7, BT7, BJ7	101	1H3087	€13.80	CIRCLIP	1	
	NA		HOUSING, clutch	1	BJ8	102	1B3736	€9.96	KNOB, gear lever	1	
2	NA		PAD, buffer	1		103	54K1723	€1.80	LOCKNUT, knob (chrome)	1	
3	10K7089	€4.80	SEAL, oil	1		104	AHB9510	€11.64	GAITER, gear lever	1	
4	BH605181	€1.92	BOLT, housing to gearbox, 2-1/4"	1		105	AHH5388	€14.76	RING, gear lever gaiter	1	
5	SH605091	€1.80	BOLT, housing to gearbox, 1-1/8"	8		110	848-920	NA	PINION, speedometer	1	
6	GHF332	€0.84	WASHER, locking	9		111	NA	BEARING, pinion	1		
8	AEC3106	€6.12	GAITER, clutch fork	1		112	324-215	NA	WASHER, bearing	1	non overdrive
9	021-928	€13.44	COVER PLATE	1		113	NA	COLLAR, pinion distance	1		
10	53K1435	€2.40	SCREW, plate	3		114	NKC105A	€5.76	SEAL, oil, pinion	1	
11	GHF331	€0.84	WASHER, locking	3		115	120694	€63.00	ANGLE DRIVE, speedometer	1	
12	1B3346	NA	COVER, starter pinion	1		116	3H550	€1.20	WASHER, adaptor	1	
13	NA		SCREW, cover to housing	3		117	LU39890	NA	SWITCH, overdrive, on gearbox	1	overdrive
14	GHF331	€0.84	WASHER, locking	3		BAU1074Z	€14.16	SWITCH, overdrive, on gearbox, aftermarket	1	BN7-BJ8 w old centre shift	
15	NA		BOLT, clutch housing to rear plate, 1-1/2"	1		118	1B3664	€0.96	WASHER, fibre	A/R	
16	NA		BOLT, clutch housing to rear plate, 1-3/8"	4							
17	324-022	€21.60	DOWEL BOLT, clutch housing to rear plate	2							
18	GHF333	€0.72	WASHER, locking	7							
19	GHF202	€0.72	NUT	6							
20	NA		CASE, gearbox	1	BN7, BT7, BJ7						
	NA		CASE, gearbox	1	BJ8						
21	6K499	€4.08	PLUG, oil drain	1							
22	NA		PLUG, interlock ball hole, threaded	1	BN7, BT7, BJ7, BJ8 to 29K-H5793						
	NA		PLUG, interlock ball hole, plain	1	BJ8 from 29K-H5794						
	MM021-053	€21.00	GASKET SET (includes ill. 25, 38 & 52)	1							
25	NA		GASKET, case to clutch housing	1	in gasket set						
26	031-341	NA	DIP STICK, oil level	1							
27	682-150	€1.32	GROMMET, dipstick	2							
30	NA		COVER, gearbox	1	BN7, BT7, BJ7						
	NA		COVER, gearbox	1	BJ8 to (g)118 non o/d & to (g)1441 o/d						
	NA		COVER, gearbox	1	BJ8 from (g)119 non o/d & (g)1442 o/d						
31	NA		COVER, gearbox	1							
32	GHF331	€0.84	PIN, locating, gear lever	2							
35	520-290	€4.20	WASHER, locking	2							
36	SEAL, oil	€4.20	SEAL, oil	1							
37	325-460	€2.04	PLUG, blanking, o/d switch hole	1	non o/d						
38	NA		ROLLPIN	2							
39	BH605151	€1.92	GASKET, gearbox to cover	1	in gasket set						
40	GHF104	€1.20	BOLT, cover to gearbox, 1-7/8"	2							
41	GHF332	€1.20	BOLT, cover to gearbox, 1-1/2"	10							
43	GHF332	€0.84	WASHER, locking	12							
44	AEG3113	NA	PLUG, plunger retaining	1							
45	AEG3122	€2.04	WASHER, plug	1							
46	AEG3124	NA	PLUNGER	1							
47	AEG3123	€3.00	SPRING, plunger	1							
48	21H6060	€6.12	CASING, gearbox extension	1							
49	NA		BREATHER	1							
50	1A3073	NA	PLUG, tapered	1	non o/d						
51	88G320	€5.64	THRUST WASHER	1							
52	NA		SEAL, oil	1							
53	BH605101	€2.16	GASKET, casing or overdrive to gearbox	1	in gasket set						
54	GHF332	€0.84	BOLT, casing to gearbox	8	non overdrive						
55	NA		WASHER, locking	8							
56	GHF332	€0.84	STUD, casing to gearbox	8							
57	GHF201	€0.84	WASHER, locking	8	overdrive						
60	NA		NUT	8							
61	NA		HOUSING, bearing	1							
65	031-342	€111.24	PEG, locating	1							
66	BLS110	€0.84	SHAFT, 3rd and 4th selector	1							
67	848-890	€210.48	BALL, shaft interlocking	2							
68	848-065	€13.68	FORK, 3rd and 4th	1							
69	BLS110	€0.84	SCREW, fork to shaft	1	BN7, BT7, BJ7						
70	329-040	€4.32	BALL, selector shaft	3	BJ8						
72	031-255	€111.24	SPRING, ball	3							
73	NA		SHAFT, 1st and 2nd selector	1							
74	NA		PIN, shaft interlocking	1							
75	NA		RIVET, interlocking pin	1							
	031-256	€340.80	FORK, 1st and 2nd	1	BN7, BT7, BJ7						
76	848-065	€13.68	FORK, 1st and 2nd	1	BJ8						
80	NA		SCREW, fork to shaft	1							
81	031-258	NA	SHAFT, reverse selector	1							
	031-258	NA	FORK, reverse	1	BN7, BT7, BJ7						
82	848-065	€13.68	FORK, reverse	1	BJ8						
85	848-820	NA	SCREW, fork to shaft	1							
86	329-105	€6.84	PLUNGER, reverse selector	1							
87	848-780	NA	SPRING, plunger	1							
88	22A75	€2.76	PLUNGER, detent	1							
90	NA		SPRING, detent plunger	1							
91	NA		SHAFT, control	1							
92	NA		SOCKET, gear lever	1	BN7, BT7, BJ7						
93	NA		SOCKET, gear lever	1	BJ8						
94	GHF332	€0.84	LEVER, selector	1							
95	WKN404	€1.80	BOLT, selector lever & gear lever	2							
96	848-980	€159.84	WASHER, locking	2							
	848-990	€159.84	WOODRUFF KEY	2							
	848-980	€159.84	LEVER, gear	1	BN7, BT7, BJ7						
	848-990	€159.84	LEVER, gear	1	BJ8						

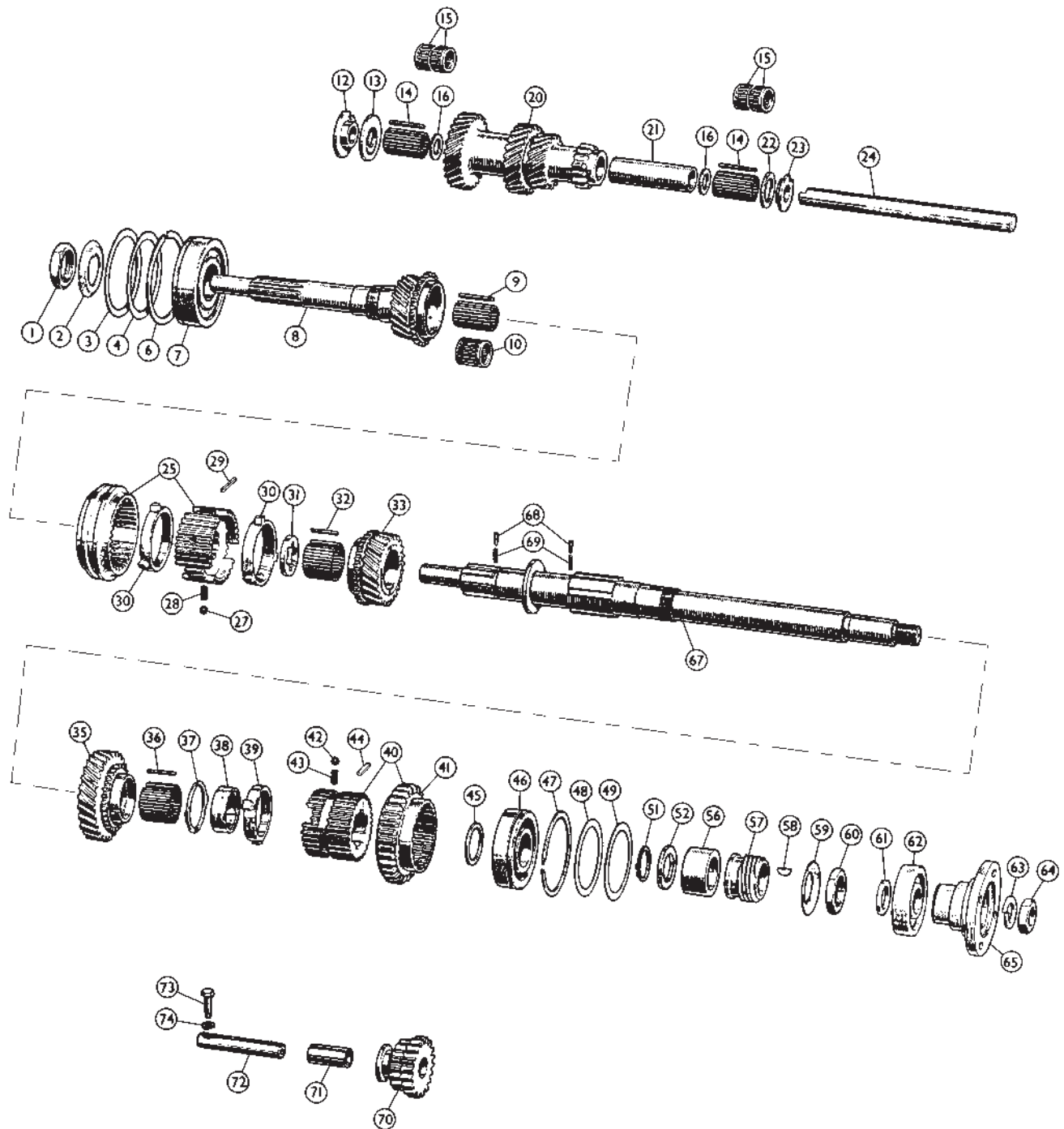

Ill.	Part Number	Price €ea.	Description	Req.	Details
Internal Gearbox, 4 speed					
1	311-090	€32.76	NUT, bearing	1	
2	021-276	NA	LOCKWASHER	1	
3	031-343	NA	PLATE, spring, bearing	1	BN2, BN4, BN6, BN7, BT7, BJ7
4	031-344	NA	PLATE, bearing	1	
	848-930	NA	SHIM, bearing, .002"	A/R	BJ8
	848-940	NA	SHIM, bearing, .004"	A/R	
6	326-740	€3.00	CIRCLIP	1	
7	6K830	€26.88	BEARING, 1st motion shaft	1	
8	031-246	NA	SHAFT, 1st motion	1	BN2
	843-085	NA	SHAFT, 1st motion	1	BN4, BN6
	843-090	NA	SHAFT, 1st motion (use 021-263 below)	1	BN7 & BT7 side-shift gbx to (e)29D-H11341 non o/d & (e)29D-H10896 o/d
	021-263	NA	SHAFT, 1st motion	1	BN7 & BT7 side-shift gbx from (e)29D-H11342 non o/d & (e)29D-H10897 o/d, BN7 & BT7 all centre-shift gbx, BJ7
	021-264	NA	SHAFT, 1st motion	1	BJ8
9	AEC3186	€0.96	BEARING, needle, 1st motion shaft	16	BN2, BN4, BN6
	AEC3186	€0.96	BEARING, needle, 1st motion shaft	18	BN7, BT7, BJ7
10	13H1565	€10.08	BEARING, caged, 1st motion shaft	1	BJ8
12	848-870	NA	PLATE, gear unit thrust, front	1	BN2 thru BJ7
	031-240	NA	PLATE, gear unit thrust, front	1	BJ8
13	031-239	€37.92	THRUST WASHER, front	1	BN2, BN4, BN6, BN7, BT7
	031-239	€37.92	THRUST WASHER, front	1	BJ7, BJ8
14	AEB3212	€0.84	BEARING, needle, laygear	46	BN2 thru BJ7
15	13H1565	€10.08	BEARING, laygear	4	BJ8
16	848-860	NA	WASHER, roller	2	BN2, thru BJ7
20	021-250	NA	LAYGEAR (1B3728)	1	BN2, BN4, BN6
	021-252	NA	LAYGEAR (AEC3359)	1	BN7 & BT7 side-shift gbx to (e)29D-H11341 non o/d & (e) 29D-H10896 o/d
		NA	LAYGEAR (AEC3471, bush type)	1	BN7 & BT7 side-shift gbx from (e)29D-H11342 to (e)29D-H14909 non o/d & (e)29D-H10897 to (e)29D-H14565 o/d
Note: The bush-type laygear can be replaced by 843-080 or 021-251, so long as all of the related later laygear components nos.14, 16, & 21 are also used.					
	843-080	€592.80	LAYGEAR (AEC3616)	1	BN7 & BT7 side-shift gbx from (e)29D-H14910 to (g)1823 non o/d & (e)29D-H14566 to (g)12319 o/d
	021-251	€620.40	LAYGEAR (AEC3649)	1	BN7 & BT7 side-shift gbx from (g) 1824 non o/d & from (g)12320 o/d, BN7 & BT7 all centre-shift gbx, BJ7
21	22B141	€592.80	LAYGEAR (22B141)	1	BJ8
		NA	SPACER, bearing	1	BN2, BN4, BN6
		NA	SPACER, bearing	1	BN7, BT7, BJ7
	848-950	NA	SPACER, bearing	1	BJ8
22	031-241	€24.60	THRUST WASHER, rear	A/R	BN7, BT7, BJ7
	031-242	NA	THRUST WASHER, rear, .072	A/R	BJ8
		NA	THRUST WASHER, rear, .075	A/R	
		NA	THRUST WASHER, rear, .078	A/R	
		NA	THRUST WASHER, rear, .081	A/R	
23	848-880	NA	PLATE, gear unit thrust, rear	1	BN2 thru BJ7
	031-244	NA	PLATE, gear unit thrust, rear	1	BJ8
24	021-331	€76.68	LAYSHAFT	1	BN2 thru BJ7
	021-332	€77.04	LAYSHAFT	1	BJ8
25	031-250	€440.40	SLIDING HUB ASSY, 3rd & 4th	1	except BJ8
	031-251	€408.00	SLIDING HUB ASSY, 3rd & 4th	1	BJ8
27	BLS110	€0.84	BALL, sliding hub	3	
28	329-125	€3.00	SPRING, ball	3	
29	031-252	€31.20	PLUNGER	2	BJ8
30	AEC3481	€55.80	SYNCHRO RING, 3rd & 4th	2	BN2 thru BJ7
	021-328	€60.12	SYNCHRO RING, 3rd & 4th	2	BJ8
31	440-180	NA	PLATE, locking	1	BN2 thru BJ7
	848-970	NA	PLATE, locking	1	BJ7, BJ8
32	AEC3180	€0.84	BEARING, needle roller	32	
33	843-060	NA	GEAR, third	1	BN2, BN4, BN6
	843-070	NA	GEAR, third	1	BN7 & BT7 side-shift gbx to (e)29D-H11341 non o/d & (e)29D-H13938 o/d
	021-261	NA	GEAR, third	1	BN7 & BT7 side-shift gbx from (e)29D-H11342 non o/d & (e)29D-H13939 o/d, BN7 & BT7 all centre-shift gbx, BJ7
	021-262	NA	GEAR, third	1	BJ8
35	021-257	NA	GEAR, second	1	BN2, BN4, BN6
	842-030	NA	GEAR, second	1	BN7 & BT7 side-shift gbx to (e)29D-H11341 non o/d & (e)29D-H13938 o/d
	842-040	NA	GEAR, second	1	BN7 & BT7 side-shift gbx from (e)29D-H11342 non o/d & (e)29D-H13939 o/d, BN7 & BT7 all centre-shift gbx, BJ7
	021-259	NA	GEAR, second	1	BJ8

Ill.	Part Number	Price €ea.	Description	Req.	Details
36	AEC3180	€0.84	BEARING, needle roller	33	
37	848-960	€14.40	THRUST WASHER, 2nd gear	2	
38	848-850	NA	PLATE, locking	2	BN2 thru BJ7
		NA	PLATE, locking	1	BJ8
39	AEC3482	€50.88	SYNCHRO RING, 2nd	1	BN2 thru BJ7
	22B149	€55.08	SYNCHRO RING, 2nd	1	BJ8
40	021-256	€609.60	GEAR, first, with sliding hub	1	stock type
	329-527	€674.40	GEAR, first, with sliding hub	1	improved - see note
Note: Original gears have a habit of jumping out of gear, especially when worn. 329-527 is produced by Denis Welch, and positively will not jump out of gear when correctly fitted.					
41	021-258	€355.20	OUTER RING, first gear	1	
42	BLS110	€0.84	BALL, sliding hub	3	
43	329-125	€3.00	SPRING, ball	3	
44	329-525	€27.72	PLUNGER	2	BJ8
45	848-830	NA	DISTANCE COLLAR, mainshaft	1	
46	128-200	€45.24	BEARING, mainshaft	1	
47	326-750	NA	CIRCLIP	1	
48	848-840	NA	PLATE, bearing	1	BN2, BN4, BN6, BN7, BT7, BJ7
49	440-140	NA	PLATE, spring, bearing	1	BT7, BJ7
	848-910	NA	SHIM, bearing	A/R	BJ8
51	58956	€1.80	CIRCLIP	1	overdrive
52	326-027	€31.08	SPACER, circlip to bearing	1	BN2, BN4, BN6, BN7 & BT7 to (e)29D-H10543 o/d
		NA	SHIM, spacer	A/R	BN2, BN4, BN6, BN7, BT7, BJ7 o/d
		NA	COLLAR, .187	A/R	BN7 & BT7 side-shift gbx, from (e)29D-H10544, BN7 & BT7 centre-shift gbx
		NA	COLLAR, .190	A/R	
		NA	COLLAR, .193	A/R	
56	326-026	€30.24	RING, collar retaining	1	BJ7, BJ8, o/d
57		NA	GEAR, speedometer	1	BN4, BN6 non o/d
		NA	GEAR, speedometer	1	BN7, BT7, BJ7, BJ8 non o/d
58		NA	KEY, gear	1	
59		NA	LOCKWASHER	1	
60		NA	LOCKNUT, gear	1	
61		NA	WASHER, bearing	1	non o/d
62	104433	€19.32	BEARING	1	
63	WL600121	€1.20	WASHER, locking	1	
64	FNZ612	€5.28	NUT, flange	1	
65	019-282	€149.28	FLANGE, coupling (remove dust cover)	1	
67		NA	MAINSHAFT, O/D	1	BN2, BN4, BN6
		NA	MAINSHAFT, O/D	1	BN7 & BT7 side-shift gbx to (e)29D-H10543
	031-345	€862.80	MAINSHAFT, O/D, stock type	1	BN7 & BT7 side-shift gbx
	031-945	€760.80	MAINSHAFT, O/D, uprated, higher, grade steel, strengthened 3rd gear locking ring	1	from (e)29D-H10544, BN7 & BT7 all centre-shift gbx, BJ7
	031-346	€768.00	MAINSHAFT, O/D	1	BJ8
		NA	MAINSHAFT, non-overdrive	1	BN4, BN6
		NA	MAINSHAFT, non-overdrive	1	BN7, BT7, BJ7
		NA	MAINSHAFT, non-overdrive	1	BJ8
68	442-100	€13.32	PLUNGER, gear	2	
69	442-110	€2.16	SPRING, plunger	2	
70	845-800	€142.80	GEAR, reverse	1	
71	330-480		BUSH, reverse gear	1	
72		NA	SHAFT, reverse gear	1	BN2
		NA	SHAFT, reverse gear	1	BN4, BN6, BN7, BT7, BJ7, BJ8
73		NA	BOLT, shaft retaining	1	
74	GHF332	€0.84	WASHER, locking	1	

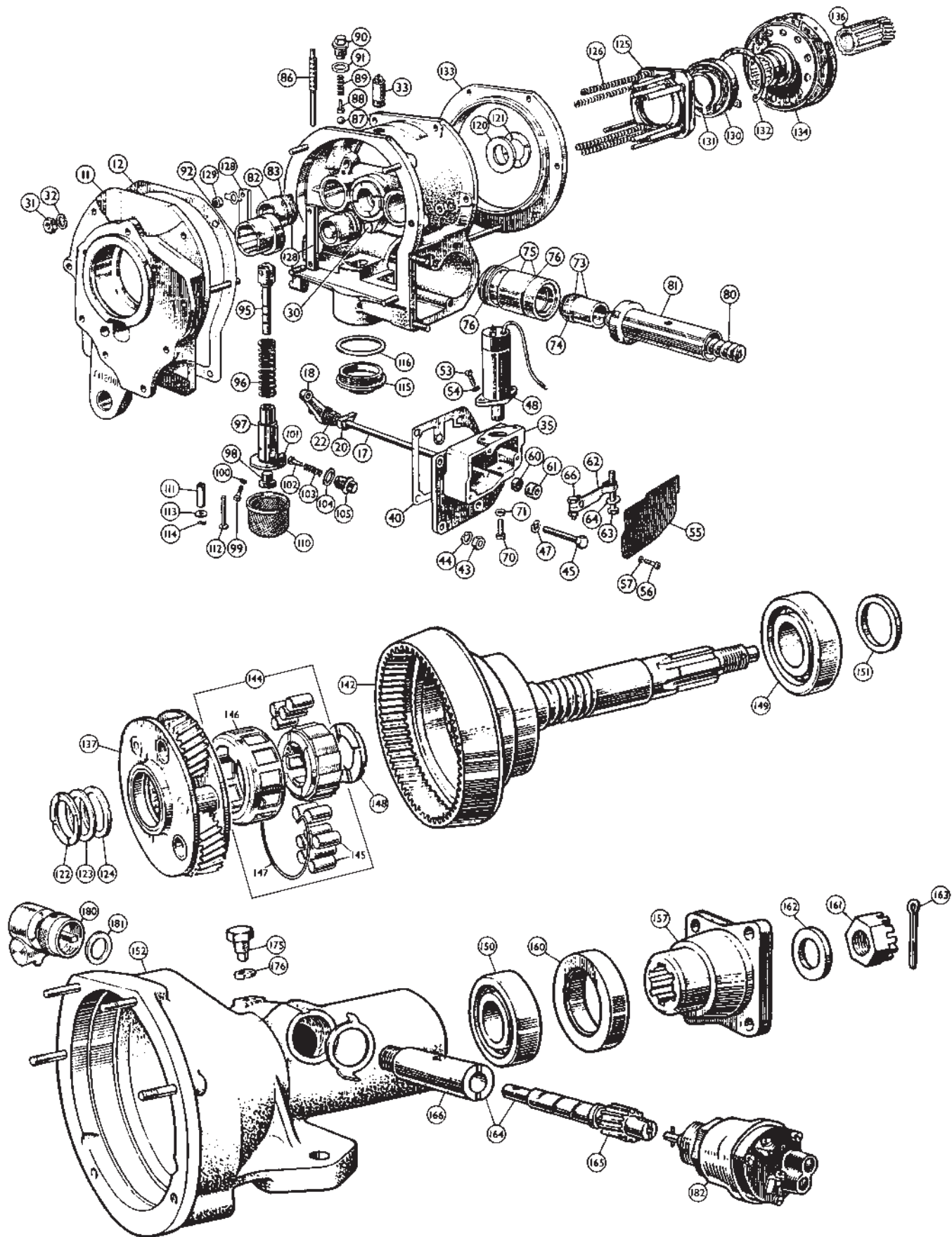

For Gearbox Mounts see page 64.

Part Number	Price €ea.	Description	Req.	Details	Part Number	Price €ea.	Description	Req.	Details
Overdrive BN1					125	500660	NA RING ASSEMBLY, clutch thrust	1	
		NA OVERDRIVE UNIT ASSEMBLY	1	BN1 to C.E.140204	126	17H5804	€72.00 SPRING SET, clutch	1	
		NA OVERDRIVE UNIT ASSEMBLY	1	BN1 from C.E.140205	128	500587	NA BRIDGE PIECE, thrust ring	2	
		NA BOLT, overdrive to gearbox	5	BN1 to C.E.140204	129	JS616A	€1.56 LOCKNUT (replaces orig. nut & tabwasher)	4	
		NA BOLT, overdrive to gearbox	5	BN1 from C.E.140205	130	500640	€28.80 BEARING, thrust ring	1	
		NA STUD, casing to gearbox	3		131	500636	€5.88 CIRCLIP, small	1	
		NA WASHER, locking	5		132	500637	€6.60 CIRCLIP, large	1	
AJD8105Z	€0.72	NUT	3		133	502555	€255.60 BRAKE RING	1	
GHF332	€0.84	WASHER, locking	3		134	520975R	€260.40 CLUTCH, reconditioned	1	
		NA GASKET SET	1		136		NA SUNWHEEL GEAR, 32% ratio	1	BN1 to O/D WN/1260/763
		(includes all gaskets for overdrive & gearbox)			137		NA CARRIER ASSY, planet, 32% ratio	1	
		NA PLATE, adaptor	1	BN1 to C.E.140204	142		NA ANNULUS, 32% ratio	1	
11		NA PLATE, adaptor	1	BN1 from C.E.140205	031-371		NA SUNWHEEL GEAR, 28% ratio	1	BN1 from O/D 28/1292/1
12	502556	€2.88 GASKET, plate to casing	1		031-379		NA CARRIER ASSY, planet, 28% ratio	1	
17		NA SHAFT, valve operating	1				NA ANNULUS, 28% ratio	1	BN1 special fitting
18	031-347	NA LEVER, shaft	1				NA SUNWHEEL GEAR, 22% ratio	1	
	500593	NA PIN, taper, lever to shaft	1				NA CARRIER ASSY, planet, 22% ratio	1	
20	513910	NA CAM, valve operating	1				NA ANNULUS, 22% ratio	1	
		NA PIN, taper, cam	1		144	BAU2061A	€150.48 ASSEMBLY, unidirectional clutch	1	
22		NA SEAL, oil, shaft	1		145	506063A	€14.76 ROLLER SET, clutch	1	
30		NA PEG, oil pump plunger guide	1		146	012610	NA CAGE, roller	1	
31	NT605041	€0.84 NUT, front casing to plate	4		147	513208	€1.56 RING, spring, clutch	1	
32	GHF332	€0.84 WASHER, locking	4		148	500613A	€27.00 THRUST WASHER, clutch to annulus	1	bronze
33		NA BREATHER	1		149	217325A	€26.04 BEARING, annulus, front	1	
35		NA BRACKET, solenoid	1		150	SP75G	€27.00 BEARING, annulus, rear	1	
40	500645	€1.32 GASKET, bracket to casing	1		151	500623E	€11.04 WASHER, steel, annulus end float	A/R	.146
43	GHF201	€0.84 NUT	2			500623F	€15.84 WASHER, steel, annulus end float	A/R	.151
44	GHF332	€0.84 WASHER, locking	2			500623G	€15.00 WASHER, steel, annulus end float	A/R	.156
45		NA BOLT, bracket to casing	2			500623H	€15.00 WASHER, steel, annulus end float	A/R	.161
	GHF301	€0.60 WASHER, plain	2			500623J	€16.56 WASHER, steel, annulus end float	A/R	.166
47	GHF332	€0.84 WASHER, locking	2		152		NA CASING, rear	1	
48	145-721	NA SOLENOID, operating, Lucas	1		157		NA FLANGE, coupling	1	BN1 to C.E.155283
	508794	€54.12 SOLENOID, operating, reproduction	1			031-372	€135.36 FLANGE, coupling	1	BN1 from C.E.155284
	7H8196	€2.16 GASKET, solenoid to bracket	1		160	NKC39A	€7.68 SEAL, oil	1	
53	PMZ308	€0.72 SCREW, solenoid to bracket	2		161	NKC81	€8.28 NUT, slotted	1	
54	GHF331	€0.84 WASHER, locking	2		162	324-615	NA WASHER, plain	1	
55		NA PLATE, cover for bracket	1	(BN1 used no gasket on this)	163		NA SPLIT PIN	1	
56	PMZ308	€0.72 SCREW, plate to bracket	3		164		NA PINION ASSEMBLY, speedometer	1	
57	GHF331	€0.84 WASHER, locking	3		165		NA PINION, speedometer	1	
60		NA SEAL, oil, valve operating shaft	1		166		NA BEARING ASSEMBLY	1	
61	502567	€6.72 COLLAR, valve operating shaft	1		175		NA BOLT, pinion locking	1	
62	502568	€28.20 LEVER, solenoid	1		176		NA WASHER	1	
63		NA SCREW, plunger to lever	1		180	768-020	€161.52 ANGLE DRIVE, speedometer	1	
64	GHF300	€1.08 WASHER	1		181	3H550	€1.20 WASHER, adaptor	1	
66	GHF117	€0.72 BOLT, lever to spindle	1		182	031-367	NA SWITCH, centrifugal, on overdrive	1	
	GHF331	€0.84 WASHER, locking	1						
	GHF200	€0.96 NUT	1						
70		NA SCREW, adjusting	1						
71	GHF206	€1.32 NUT	1						
73	501909	€101.04 ACCUMULATOR PISTON, with rings	1						
74	505555	€83.40 RING SET, piston	2						
75	501908	€61.92 HOUSING, accumulator	1						
76	501910	€4.80 RING, rubber	2						
80	866-670	NA SPRING, accumulator pressure	1						
81	031-348	€13.44 TUBE, spring	1						
82	513890	€43.20 PISTON ASSEMBLY, operating	2						
83	503162	€58.44 PISTON RING SET, cast iron	4						
86	500658	€35.64 VALVE, operating	1						
87	BLS110	€0.84 BALL, sliding hub	3						
88	500591	€14.88 PLUNGER	1						
89	007972	€7.56 SPRING	1						
90	506117	€24.72 PLUG, screwed	1						
91	3H693	€1.56 WASHER, copper	1						
92	500627	€75.00 CAM, oil pump	1						
95	513891	€119.40 PLUNGER, oil pump	1						
96	500633	€8.76 SPRING	1						
97	505507	€124.68 BODY, oil pump	1						
98	513902	€11.64 PLUG, threaded	1						
99	53K126	€1.08 SCREW, pump body to front casing	2						
100	GHF331	€0.84 WASHER, locking	2						
101	BLS108	€3.24 BALL, valve	1						
102	500591	€14.88 PLUNGER	1						
103	007972	€7.56 SPRING	1						
104	3H693	€1.56 WASHER, copper	1						
105	506117	€24.72 PLUG, threaded	1						
110	509884	€32.88 STRAINER, oil pump	1						
111		NA DISTANCE TUBE, strainer	1						
112	103270	NA BOLT, strainer	1						
113	WP9	€2.04 WASHER, plain	1						
114	GHF331	€0.84 WASHER, locking	1						
115		NA PLUG, oil drain	1						
116	500641	€2.04 WASHER, fibre	1						
120	500588A	€16.68 WASHER, steel, sunwheel adjusting	A/R	front, (.113-.114)					
	500588B	€16.68 WASHER, steel, sunwheel adjusting	A/R	front, (.107-.108)					
	500588C	€16.68 WASHER, steel, sunwheel adjusting	A/R	front, (.101-.102)					
	500588D	€16.68 WASHER, steel, sunwheel adjusting	A/R	front, (.095-.096)					
	500588E	€16.68 WASHER, steel, sunwheel adjusting	A/R	front, (.089-.090)					
	500588F	€16.68 WASHER, steel, sunwheel adjusting	A/R	front, (.083-.084)					
	500588G	€16.68 WASHER, steel, sunwheel adjusting	A/R	front, (.077-.078)					
121	500610	€26.04 THRUST WASHER, bronze, sunwheel	1	front					
122	031-373	NA THRUST WASHER, bronze, planet carrier	1	front					
123	031-374	NA THRUST WASHER, steel	1	middle					
124	505548	€32.28 THRUST WASHER, bronze,	1	rear					

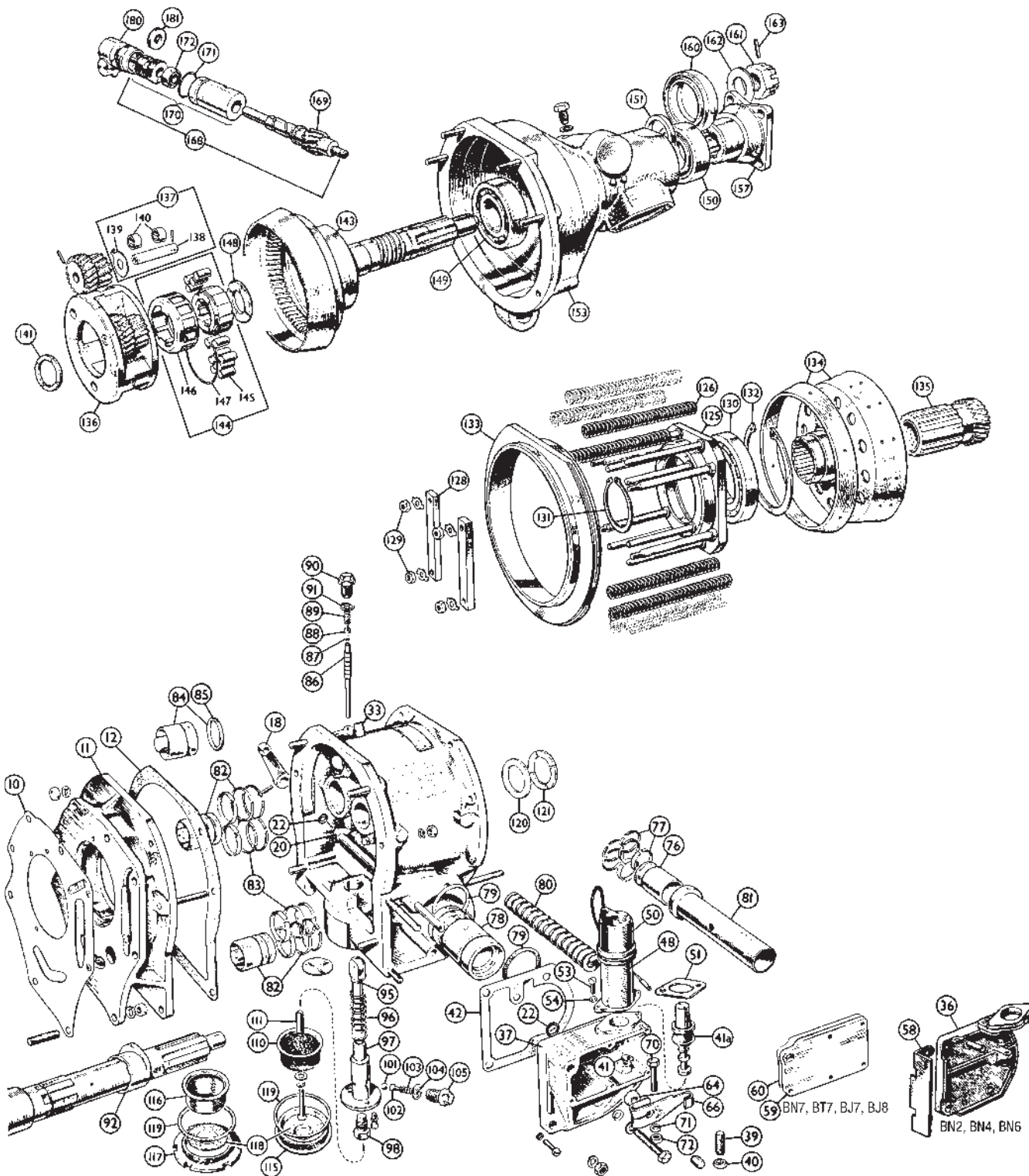

For Gearbox Mounts see page 64.

Part Number	Price €ea.	Description	Req.	Details	Part Number	Price €ea.	Description	Req.	Details	
Overdrive BN2 thru BJ8					500588D	€16.68	WASHER, steel, sunwheel adjusting	A/R	front, (.095-.096)	
1		NA OVERDRIVE UNIT ASSEMBLY	1	BN2	500588E	€16.68	WASHER, steel, sunwheel adjusting	A/R	front, (.089-.090)	
		NA OVERDRIVE UNIT ASSEMBLY	1	BN4 to C.E48862	500588F	€16.68	WASHER, steel, sunwheel adjusting	A/R	front, (.083-.084)	
		NA OVERDRIVE UNIT ASSEMBLY	1	BN4 from C.E48863, BN6	500588G	€16.68	WASHER, steel, sunwheel adjusting	A/R	front, (.077-.078)	
		NA OVERDRIVE UNIT ASSEMBLY	1	BN7 & BT7 to (e)29E-H2245	121 500610	€26.04	THRUST WASHER, bronze, sunwheel	1	front	
		NA OVERDRIVE UNIT ASSEMBLY	1	BN7 & BT7 from	125 500660		NA RING ASSEMBLY, clutch thrust	1		
		(e)29E-H2246, BJ7	1		126 17H5804	€72.00	SPRING SET, clutch	1		
		BJ8	1		128 500587		NA BRIDGE PIECE, thrust ring	2		
MM021-053	€21.00	OVERDRIVE UNIT ASSEMBLY	1		129 JS616A	€1.56	LOCKNUT (replaces original nut & locktab)	4		
		GASKET SET	1		130 500640	€28.80	BEARING, thrust ring	1		
		(inc. all gaskets for overdrive & gearbox)	1		131 500636	€5.88	CIRCLIP, small	1		
10		NA GASKET, overdrive to gearbox	1	BN2, BN4, BN6, BN7, BT7	132 500637	€6.60	CIRCLIP, large	1		
		GASKET, overdrive to gearbox	1	to (e)29E-H2245	133 502555	€255.60	BRAKE RING	1		
			1	BN7 & BT7 from	134 520975R	€260.40	CLUTCH, reconditioned	1		
			1	(e)29E-H2246, BJ7, BJ8	135 031-371		NA SUNWHEEL GEAR, 28% ratio	1	BN2, BN4, BN6	
11		NA PLATE, adaptor	1	BN2 to C.E.230489	031-378		NA SUNWHEEL GEAR, 22% ratio	1	BN7, BT7, BJ7, BJ8	
		NA PLATE, adaptor	1	BN2 from CE230490, BN4, BN6	136 031-379		NA CARRIER ASSY, planet, 28% ratio	1	BN2, BN4, BN6	
		NA PLATE, adaptor	1	BN7 & BT7 to (e)29E-H2245	031-381		NA CARRIER ASSY, planet, 22% ratio	1	BN7, BT7, BJ7, BJ8	
		NA PLATE, adaptor	1	BN7 & BT7 from	137 505546	€142.32	BEARING & SHAFT KIT	1		
		(e)29E-H2246, BJ7	1		138 031-383		NA SHAFT, planet wheel	3		
		BJ8	1		139		NA WASHER, thrust	3		
12	502556	€2.88	GASKET, plate to casing	1	in gasket set	140 866-520	€10.32	BEARING	6	
18	031-347		NA LEVER, shaft	1		141 505548	€32.28	WASHER, bronze, sunwheel thrust, rear	1	
20	513910		NA CAM, valve operating	1		143		ANNULUS, 28% ratio	1	BN2, BN4, BN6
22	500594	€2.04	O RING	2		031-382		ANNULUS, 22% ratio	1	BN7, BT7, BJ7, BJ8
33			NA BREATHER	1	as fitted	144 BAU2061A	€150.48	ASSEMBLY, unidirectional clutch	1	
36	502566	€123.24	BRACKET, solenoid	1	BN2, BN4, BN6	145 506063A	€14.76	ROLLER SET, clutch	1	
37			NA BRACKET, solenoid	1	BN7 & BT7 to O/D	146 012610		NA CAGE, roller	1	
				1	22/3087/10259	147 513208	€1.56	RING, spring, clutch	1	
			NA BRACKET, solenoid	1		148 500613A	€27.00	WASHER, thrust, bronze, clutch to annulus	1	
39			NA SCREW, adjusting	1	22/3087/10260, BJ7, BJ8	149 217325A	€26.04	BEARING, annulus, front	1	
40			NA LOCKNUT	1		150 SP75G	€27.00	BEARING, annulus, rear	1	
41			NA STOP, rubber	1	BN2, BN4, BN6, BN7,	151 500623E	€11.04	WASHER, steel, annulus end float, .146	A/R	
41a			NA BOOT, rubber	1	BT7, BJ7, BJ8	500623F	€15.84	WASHER, steel, annulus end float, .151	A/R	
42	500645	€1.32	GASKET, bracket to casing	1	in gasket set	500623G	€15.00	WASHER, steel, annulus end float, .156	A/R	
48	145-721		NA SOLENOID, operating, Lucas	1	BN2 thru BN7 & BT7 to	500623H	€15.00	WASHER, steel, annulus end float, .161	A/R	
	508794	€54.12	SOLENOID, operating, reproduction	1	(e)29E-2245	500623J	€16.56	WASHER, steel, annulus end float, .166	A/R	
	AEJ42	€61.08	SOLENOID, operating	1	BN7 & BT7 from		NA CASING, rear	1		
				1	(e)29E-H2246, BJ7, BJ8	153		FLANGE, coupling	1	
50	109521	€26.88	COVER, solenoid	1		157 031-372	€135.36	FLANGE, coupling	1	
51	7H8196	€2.16	GASKET, solenoid to bracket	1		160 NKC39A	€7.68	SEAL, oil	1	
53	PMZ308	€0.72	SCREW, solenoid to bracket	2		161 NKC81	€8.28	NUT, slotted	1	
54	GHF331	€0.84	WASHER, locking	2		162 324-615		NA WASHER, plain	1	
58			NA STONEGUARD, solenoid	1	BN2, BN4, BN6	168 021-595	€164.88	PINION ASSEMBLY, speedometer	1	BN2, BN4, BN6
59			NA PLATE, solenoid to bracket cover	1	BN7, BT7, BJ7, BJ8	169		NA PINION, speedometer	1	
60	866-700		NA GASKET, plate to bracket	1		021-596	€164.88	PINION ASSEMBLY, speedometer	1	BN7, BT7, BJ7, BJ8
64	502567	€6.72	COLLAR, valve operating shaft	1	BN2 thru BJ8		NA PINION, speedometer	1		
66	502568	€28.20	LEVER, solenoid	1		170 120-720		NA BEARING ASSEMBLY	1	
70	GHF117	€0.72	BOLT, lever to spindle	1		171 120-730	€1.44	O RING	1	
71	GHF331	€0.84	WASHER, locking	1		172 120-710	€6.84	SEAL, oil	1	
72	GHF200	€0.96	NUT	1		180 768-020	€161.52	ANGLE DRIVE, speedometer	1	BN2
76	501909	€101.04	ACCUMULATOR PISTON, with rings	1		120694	€63.00	ANGLE DRIVE, speedometer	1	BN4 thru BJ8
77	505555	€83.40	RING SET, piston	1		181 3H550	€1.20	WASHER, adaptor	1	
78	501908	€61.92	HOUSING ASSEMBLY, accumulator	1						
79	501910	€4.80	"O" RING	2/1	(late 3000 used one)					
80	866-670		NA SPRING, accumulator pressure	1	BN2 to O/D28/1447/586					
	866-680	€33.72	SPRING, accumulator pressure	1	BN2 thru BJ8					
81	031-348	€13.44	TUBE, spring	1						
82	513890	€43.20	PISTON ASSEMBLY, operating, (repl.)	2	BN2					
	513890	€43.20	PISTON ASSEMBLY, operating	2	BN4, BN6, BN7 & BT7 to					
			(replacement)	1	O/D 22/3009/607					
83	503162	€58.44	PISTON RING SET, cast iron	4	BN2, BN4, BN6, BN7 &					
			(orig pistons only)	1	BT7 to O/D 22/3009/607					
84	513890	€43.20	PISTON ASSEMBLY, operating	2	BN7 & BT7 from O/D					
				1	22/3009/608, BJ7, BJ8					
85	513912	€1.68	O RING, operating piston	2						
86	500658	€35.64	VALVE, operating	1						
87	BLS110	€0.84	BALL, sliding hub	3						
88	500591	€14.88	PLUNGER	1						
89	007972	€7.56	SPRING	1						
90	506117	€24.72	PLUG, threaded	1						
91	3H693	€1.56	WASHER, copper	1						
92	500627	€75.00	CAM, oil pump	1						
95	513891	€119.40	PLUNGER, oil pump	1						
96	500633	€8.76	SPRING	1						
97	505507	€124.68	BODY, oil pump	1						
98	513902	€11.64	PLUG, threaded	1						
101	BLS108	€3.24	BALL BEARING, valve	1						
102	500591	€14.88	PLUNGER	1						
103	007972	€7.56	SPRING	1						
104	3H693	€1.56	WASHER, copper	1						
105	506117	€24.72	PLUG, screwed	1						
110	509884	€32.88	FILTER, oil pump	1	BN2, BN4, BN6, BN7, BT7					
			NA DISTANCE TUBE, strainer	1	to O/D 22/3009/8744					
			NA PLUG, oil drain (use no. 117)	1						
116	509884	€32.88	FILTER, oil pump	1	BN7 & BT7 from O/D					
				1	22/3009/8745, BJ7, BJ8					
117	521814	€87.48	PLUG, oil drain	1	BN7 & BT7 from O/D					
				1	22/3009/608, BJ7, BJ8					
118	513205	€20.52	MAGNET (set of 3)	1	BN7 & BT7 from O/D					
				1	22/3009/8745, BJ7, BJ8					
119	500641	€2.04	WASHER, fibre	1						
120	500588A	€16.68	WASHER, steel, sunwheel adjusting	A/R	front, (.113-.114)					
	500588B	€16.68	WASHER, steel, sunwheel adjusting	A/R	front, (.107-.108)					
	500588C	€16.68	WASHER, steel, sunwheel adjusting	A/R	front, (.101-.102)					

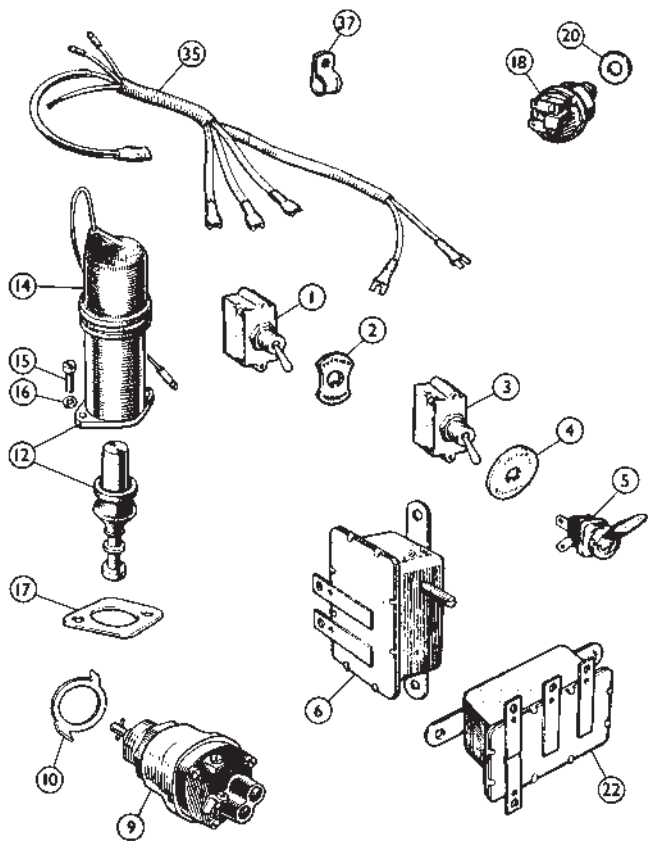

Part Number	Price €ea.	Description	Req.	Details
1		NA SWITCH, overdrive, on dash, O.E.	1	BN1
141-240	€15.72	SWITCH, overdrive, on dash, repl.	1	
2	€27.12	ESCUTCHEON PLATE	1	
3	€15.72	SWITCH, overdrive, on dash	1	BN2, BN4, BN6, BN7, BT7, BJ7
4	€21.24	ESCUTCHEON PLATE	1	
5	€7.44	SWITCH, overdrive, on dash	1	BJ8
6	€122.64	THROTTLE SWITCH	1	all cars with overdrive
9	NA	SWITCH, centrifugal, on overdrive	1	BN1
10	NA	WASHER	1	
12	NA	SOLENOID, operating, Lucas	1	BN2 thru BN7 & BT7 to (e)29E-2245
508794	€54.12	SOLENOID, operating, reproduction	1	
AEJ42	€61.08	SOLENOID, operating	1	BN7 & BT7 from (e)29E-H2246, BJ7, BJ8
14	€26.88	COVER, solenoid	1	
15	€0.72	SCREW, solenoid to bracket	2	
16	€0.84	WASHER, locking	2	
17	€2.16	GASKET, solenoid to bracket	1	
18	NA	SWITCH, isolator (screw terminal)	1	alternatives
LU39890	NA	SWITCH, isolator (Lucar terminal)	1	
20	€0.96	WASHER, isolator switch adjusting	A/R	
22	€92.28	RELAY, overdrive (BN1 uses 2)	2/1	BN1-BJ7
142169A	NA	RELAY, overdrive	1	BJ8
35	€43.20	HARNES, overdrive	1	BN1
	NA	CABLE, switch to solenoid	1	BN2 (may use later harness)
	NA	CABLE, switch to relay	1	
	NA	CLIP	1	
356-425	€47.76	HARNES, overdrive,	1	BN4 thru BJ7
356-415	€38.64	HARNES, overdrive, braided covering	1	early BJ8
356-420	€28.08	HARNES, overdrive, vinyl covering	1	late BJ8
37	€1.92	CLIP, harness to dash	1	BN4 thru BJ8
PCR407	€2.40	CLIP, harness to gearbox side cover	1	
PCR311	€2.52	CLIP, harness to engine side cover	1	

Overdrive Electrical

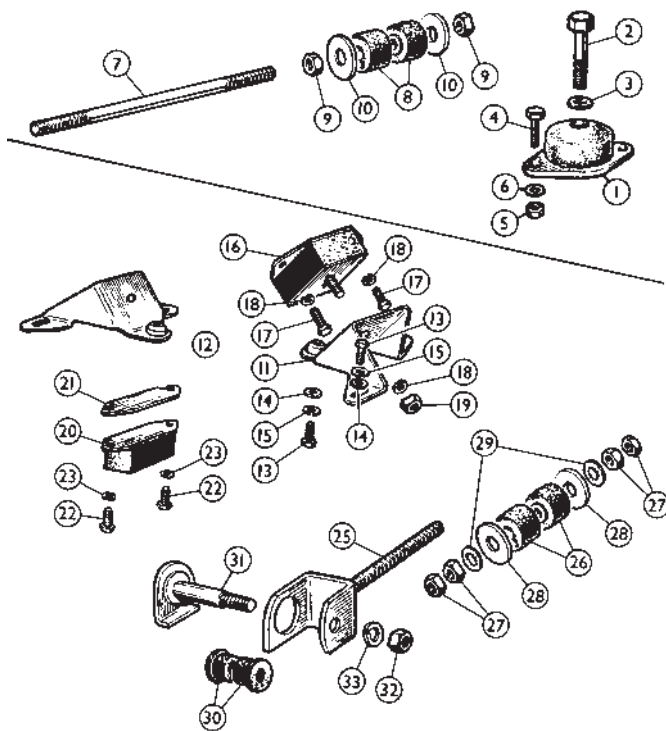

Part Number	Price €ea.	Description	Req.	Details
1	NA	MOUNTING, gearbox, BSF	2	BN1 to C.E.221011
				Note: the BSF threaded mounting is no longer supplied. Use C4794 with two UNF threaded bolts; do not reuse the packing pieces, since they are only for fitment with the BSF mounting.
	C4794	€19.68 MOUNTING, gearbox, UNF	2	BN1 from C.E.221012
2	031-368	NA BOLT, UNF, overdrive to mounting	2	
3	GHF335	€0.96 WASHER, locking	2	
	NA	PACKING PIECE	2	BN1 to C.E.221011
4	SH605071	€1.20 BOLT, mounting to chassis	4	
5	LNZ105	€1.68 NUT	4	
6	GHF301	€0.60 WASHER, plain	4	
7	NA	TIE ROD, engine	1	
8	3H3079	NA BUSH, tie rod, rubber	4	
	021-777	€6.00 BUSH, tie rod, polyurethane	4	
	3H3079SPK	€22.56 BUSH KIT, link, polyurethane, SuperPro	1	
9	FNZ506	€1.32 NUT	4	
10	PWZ206	€1.20 WASHER, plain	4	
Gearbox Mountings BN2 - BJ8				
11	031-384	€30.48 BRACKET, mounting, LH	1	
12	031-385	€30.48 BRACKET, mounting, RH	1	
13	SH605051	€1.80 BOLT, bracket to chassis	6	
14	GHF301	€0.60 WASHER, plain	6	
15	GHF332	€0.84 WASHER, locking	6	
16	GEX7453	€6.12 MOUNTING, gearbox	2	
17	GHF120	€0.72 BOLT, mounting to gearbox rear cover	4	
18	GHF332	€0.84 WASHER, locking	6	
19	GHF201	€0.84 NUT	2	
20	1A9209	€7.08 REBOUND RUBBER	1	
21	031-369	NA SHIM	A/R	
22	SH604051	€0.72 BOLT, to gearbox rear cover	2	
23	GHF331	€0.84 WASHER, locking	2	
25	1G9382	€21.24 TIE ROD, engine	1	
26	3H3079	€1.68 BUSH, tie rod, rubber	2	
	021-777	€6.00 BUSH, tie rod, polyurethane	2	
	3H3079SPK	€22.56 BUSH KIT, link, polyurethane, SuperPro	1	
27	NT606041	€1.08 NUT	4	
28	PWZ206	€1.20 WASHER, plain	2	
29	GHF323	€0.96 WASHER, shakeproof	2	
30	1B8347	€2.76 BUSH, rubber, gearbox rear cover	2	
	280-054	€16.44 BUSH PAIR, polyurethane replacement	1	
31	1G9384	€18.36 PIN, hinge	1	
32	GHF202	€0.72 NUT	1	
33	GHF333	€0.72 WASHER, locking	1	

Gearbox Mountings BN1



100S

The 100S is the most desirable Austin-Healey ever produced. A total of only 55, including 5 factory development cars, were produced during 1954 and 1955. The car pictured here is the third of those five, differing from "standard" 100S in retaining the top frame and stock windscreen. Most but not all 100S were finished in white over blue.

Exterior body panels of the 100S were aluminium alloy. Hundreds of detail modifications from the standard BN2, including crossflow cylinder heads and 4-wheel disc brakes, made these cars very special indeed.

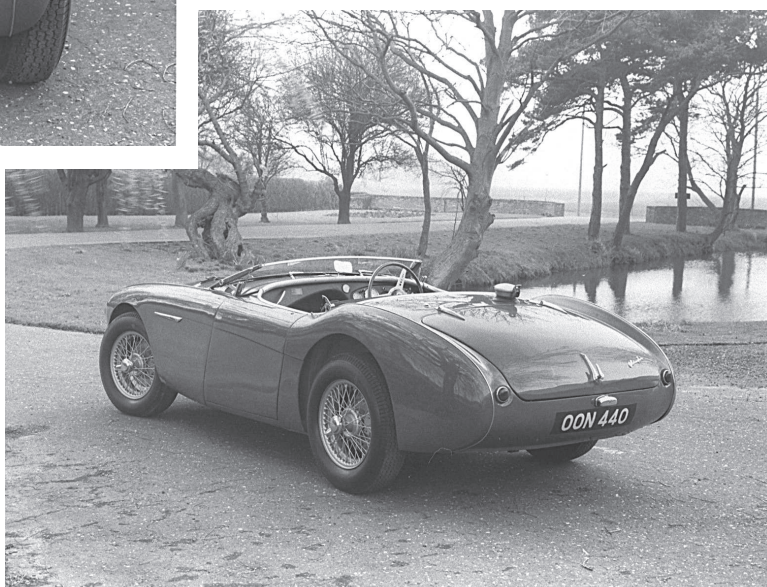

Note the special vented seat backs.

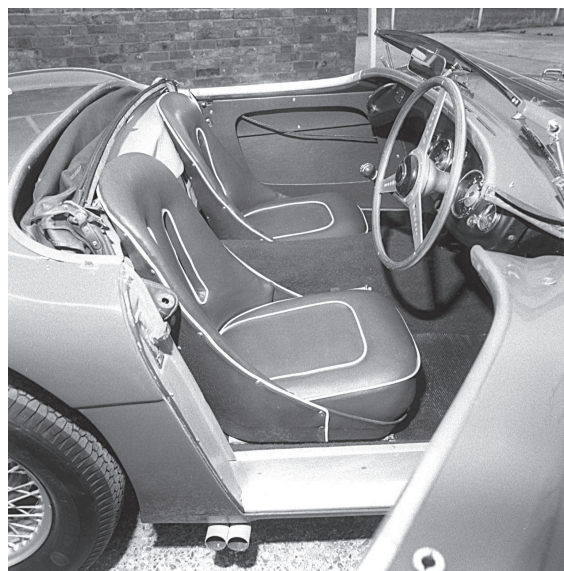
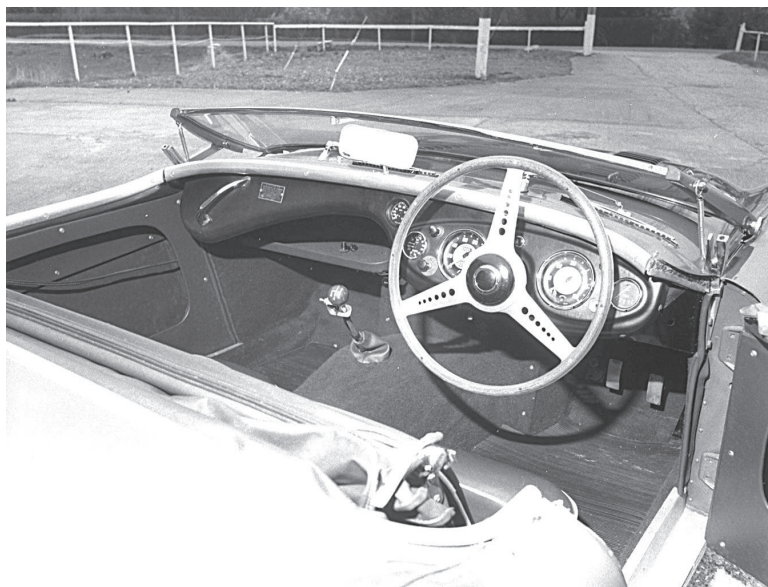

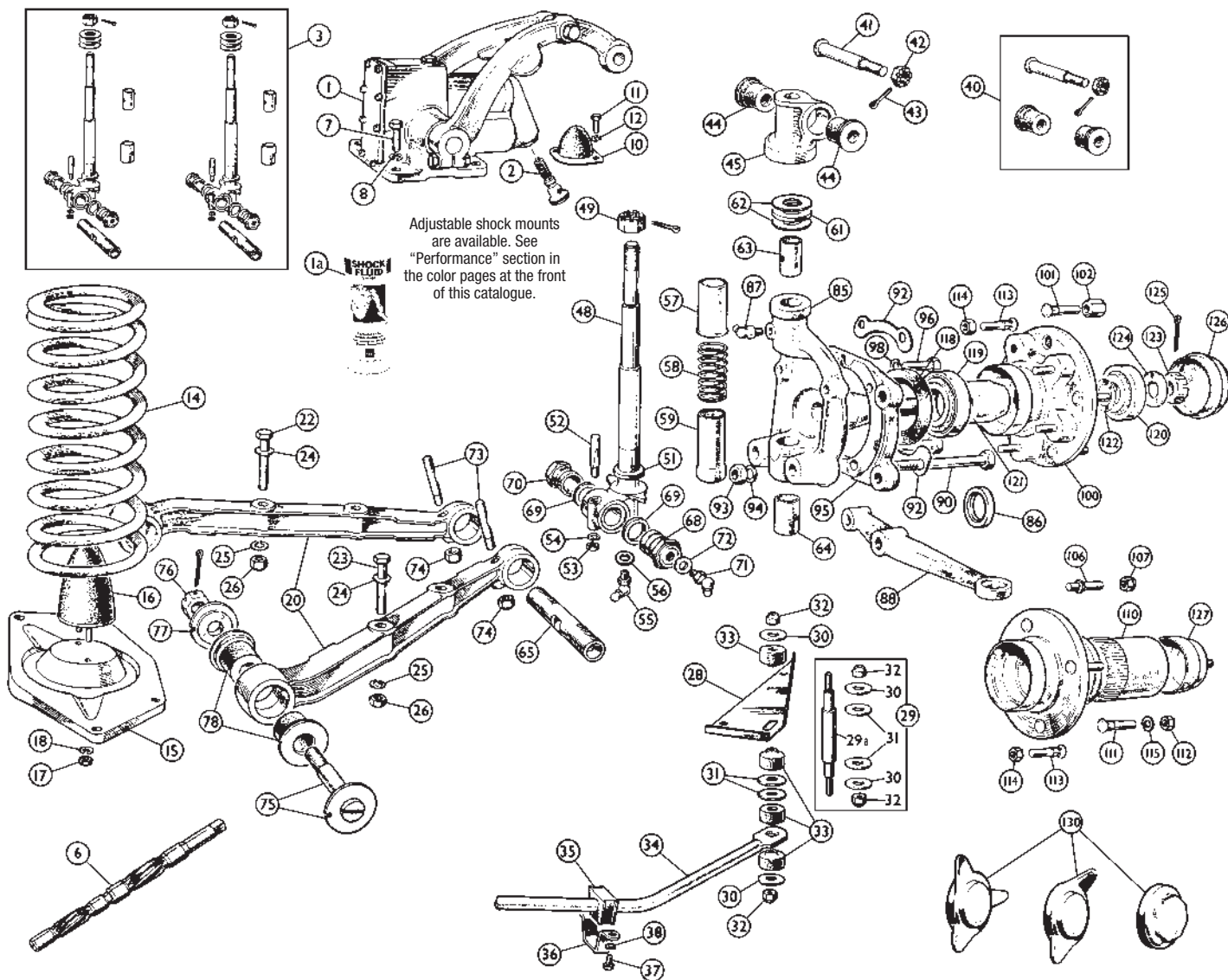

ill.	Part Number	Price €ea.	Description	Req.	Details
Front Suspension					
1	GSA111E	€283.20	SHOCK ABSORBER, OE, rebuilt NA CORE CHARGE for 655-055 Core must be an original, not a replacement shock.	2	
	GSA111	€247.20	SHOCK ABSORBER, front, replacement (Has 1/2" higher air chamber, and may require modification to sheet metal above shock.)	2	
1a	GGL832110	€11.76	SHOCK ABSORBER FLUID, 16 oz.	1	
2	655-060	€38.04	VALVE (for racing purposes)	2	see page 77
3	QHQP295TCF	€147.96	KING PIN SET, does two sides	1	
6	386-375	€554.40	REAMER, swivel pin bushes	1	
7	GHF105	€0.84	BOLT, shock to frame	8	
8	GHF333	€0.72	WASHER, locking	8	
10	1G4276	€3.36	BUFFER, rebound	2	
11	SH604051	€0.72	BOLT, buffer to frame	4	
12	GHF331	€0.84	WASHER, locking	4	
14	661-910	€50.76	SPRING, coil	2	BN1, BN2, BN4 to C.E.35076 LHD & 35826 RHD
	661-910	€50.76	SPRING, coil	2	BN4 from C.E.35077 LHD, 35827 RHD, BN6, BN7 to (c)10328, BT7 to (c)10302
	1H4092	€64.08	SPRING, coil	2	BN7 from (c)10329, BT7 from (c)10303

ill.	Part Number	Price €ea.	Description	Req.	Details
	1H4092	€64.08	SPRING, coil	2	BJ7, BJ8
	15	ACB4066	SEAT, spring	2	
	16	NA	BUMP STOP, 3" (BSF thread)	2	BN1
	16	1B4501	BUMP STOP, 3-5/16" (UNF thread)	2	BN2-BJ8
	17	NA	NUT, BSF	4	BN1 (as fitted)
	17	GHF201	NUT, UNF	4	BN2-BJ8
	18	GHF332	WASHER, locking	4	
	20	661-830	LINK, lower	4	BN1
	20	031-280	CONTROL ARM, LH front & RH rear	2	BN2, BN4, BN6, BN7, BT7, BJ8
	661-840	€261.60	CONTROL ARM, RH front & LH rear	2	
	ACB9274SPK	€94.08	CONTROL ARM BUSHING SET	1	Polyurethane, SuperPro
	22	BH606181	BOLT, spring seat to lower link	4	
	23	BH606201	BOLT, spring seat & anti-roll bar to lower link	4	
	24	WP9	WASHER, plain	8	
	25	GHF333	WASHER, locking	8	
	26	GHF223	NUT, nyloc, UNF	8	
	28	662-040	PLATE, anti-roll bar, RH	1	
	28	662-050	PLATE, anti-roll bar, LH	1	
	29	1B4486	LINK ASSY, anti-roll bar	2	
	29a	661-811	LINK	2	
	30	WP185	WASHER, link bush, end	4	
	31	140416	WASHER, link bush, centre	4	
	32	GHF222	NUT, nyloc	4	
	32	LNZ105	NUT, original type "Aerotight"	4	
	33	3H3079	BUSH, link, rubber	8	
	33	3H3079SPK	BUSH KIT, link, Polyurethane, SuperPro	1	
	021-777	€6.00	BUSH, link, Prothane	8	

ill.	Part Number	Price €ea.	Description	Req.	Details
34		NA	ANTI-ROLL BAR, 1/2"	1] BN1, BN2
	031-281	€164.88	ANTI-ROLL BAR, 5/8"(uprated)	1	
	031-281	€164.88	ANTI-ROLL BAR, 5/8"	1	
	031-495	€175.80	ANTI-ROLL BAR, 3/4", (uprated)	1] 100M, BN4 to BJ8
35	682-140	€1.80	BUSH, 1/2" anti-roll bar, rubber	2	
	1B4526	€1.92	BUSH, 5/8" anti-roll bar, rubber	2	
	1B4526SPK	€25.80	BUSH SET, 5/8" anti-roll bar, poly	1	
	AHH7927	€2.16	BUSH, 3/4" anti-roll bar, rubber	2	
36	BHH2000	€2.88	STRAP, bush	2	
37		NA	BOLT, bush strap	4	BN1, BN2
	GHF120	€0.72	BOLT, bush strap	4	BN4 to BJ8
38	GHF332	€0.84	WASHER, locking	4	
40	1G4349K	€9.36	TOP TRUNNION KIT	2	includes ill. 41, 42, 43 & 44
41	1G4349	€4.56	PIN, fulcrum, UNF	2	
42	NL607041	€2.88	NUT, fulcrum pin, UNF	2	
43	GHF502	€1.08	SPLIT PIN	2	
44	8G621Z	€2.76	BUSH, top link, rubber	4	
	282-325	NA	BUSH SET, top link, polyurethane	1	
45	031-274	€100.68	TRUNNION, suspension link	2	
48		NA	PIN, swivel, UNF	2	
49		NA	NUT, swivel pin, BSF	2	BN1 (as fitted)
	252165	€3.00	NUT, swivel pin, UNF, nyloc	2	All other models
51	AUC2118	€2.04	SEAL, swivel pin, cork	2	
52	53K1770	€4.08	PIN, split, UNF	2	
53	AJD8104	€1.08	NUT, split pin, BSF	2	BN1 (as fitted)
	GHF200	€0.96	NUT, split pin, UNF	2	All other models
54	GHF331	€0.84	WASHER, locking	2	
55		NA	NIPPLE, grease, BSF	2	BN1 (as fitted)
	LN30041	€2.16	NIPPLE, grease, UNF	2	All other models
56	WF507	€0.84	WASHER, fibre	2	
57	1G4271	€5.28	TUBE, dust excluder, top	2	
58	2K8951	€1.68	SPRING, dust excluder	2	
59	1A4756	€14.16	TUBE, dust excluder, bottom	2	BN1, BN2, BN4, BN6, BN7, BT7, BJ7 to (c)21766
	1A4756	€14.16	TUBE, dust excluder, bottom	2	BJ7 from (c)21767, BJ8
		NA	RING, sealing, tube	2	
61		NA	WASHER, thrust (bronze)	2	
62		NA	WASHER, thrust, floating, .052-.057	A/R	
		NA	WASHER, thrust, floating, .058-.063	A/R	
		NA	WASHER, thrust, floating, .065-.069	A/R	
	031-195	€58.92	TRUNNION BEARING KIT	1	(replaces thrust washers)
	031-196	€1.08	SHIM, trunnion bearing kit	A/R	
63	1A4744	€8.28	BUSH, top	2	
64	1A4745	€8.64	BUSH, bottom	2	
65	1A4788	€14.28	PIN, fulcrum, lower link, outer	2	
68	661-870	€17.04	BUSH, lower link, front	2	
69	1G4505	€1.08	RING, fulcrum pin, cork	4	
70	661-880	€15.72	BUSH, lower link, rear	2	
71		NA	NIPPLE, grease	2	BN1
72	2K4958	€0.84	WASHER, fibre	2	
71	LN30041	€2.16	NIPPLE, grease, UNF	2	BN2 thru BJ8
72	324-225	€1.08	WASHER, fibre	2	
73	1G4350	€2.64	PIN, cotter, lower link to swivel pin fulcrum.	4	UNF
74	GHF272	€1.20	NUT, cotter pin, UNF	4	
75	1B4513K	€15.48	PIN ASSY, fulcrum, lower link, inner	4	(incl. #76, 77)
76	NL608041	€2.28	NUT, fulcrum pin, UNF	4	
77		NA	WASHER, fulcrum pin	4	
78	ACB9274	€2.52	BUSH, lower link	8	
85		NA	AXLE ASSEMBLY, swivel, BSF	2	BN1 to C.E.221403
		NA	AXLE ASSEMBLY, swivel, UNF	2	BN1 from C.E.221404
		NA	AXLE ASSEMBLY, swivel, UNF	2	BN2 to C.E.231202 LHD, 231147 RHD
	031-273	NA	AXLE ASSEMBLY, swivel, UNF	2	BN2 from C.E.231203 LHD & 231148 RHD, BN4, BN6, BN7, BT7, BJ7 to (c)21766
	031-386	NA	AXLE ASSEMBLY, swivel, UNF	2	BJ7 from (c)21767, BJ8 to (c)26704
	664-440	€750.00	AXLE ASSY, swivel, UNF, LH	1	BJ8 from (c)26705
	664-445	€750.00	AXLE ASSY, swivel, UNF, RH	1	
86	031-387	€50.76	SPACER, swivel axle	2	
87		NA	NIPPLE, grease, BSF	2	BN1 to C.E.221403
	LN30041	€2.16	NIPPLE, grease, UNF	2	BN1 from C.E.221404, BN2, BN4, BN6, BN7, BT7, BJ8
88	021-278	€160.68	LEVER, steering, RH	1	BN1
	021-288	€160.68	LEVER, steering, LH	1	
	031-278	€160.68	LEVER, steering, RH	1	BN2 thru BJ8
	031-388	€160.68	LEVER, steering, LH	1	
90		NA	BOLT, lever to swivel axle, BSF	4	BN1 (as fitted)
	BH607241	€2.28	BOLT, lever to swivel axle, UNF, short	2	BN2, BN4, BN6
		NA	BOLT, lever to swivel axle, UNF, long	2	
	322-720	€1.32	BOLT, lever to swivel axle, UNF, short	2	BN7, BT7, BJ7, BJ8 to (c)26704
	HBZ730	€4.44	BOLT, lever to swivel axle, UNF, long	2	BJ8 from (c)26705
		NA	BOLT, lever to swivel axle, UNF, short	2	
		NA	BOLT, lever to swivel axle, UNF, long	2	
92	661-930	NA	LOCKTAB	4	BN1
93	AJD8106Z	€0.96	NUT, BSF	4	
92	661-930	NA	LOCKTAB	2	BN2, BN4, BN6, BN7, BT7, BJ7, BJ8 to (c)26704
	FNZ507	€1.68	NUT, UNF	4	
94	GHF334	€1.32	WASHER, locking	4	BN7, BT7, BJ7, BJ8 to (c)26704
95		NA	PLATE, adaptor, RH	1	
		NA	PLATE, adaptor, LH	1	
96		NA	BOLT, plate to swivel axle, UNF	4	BN1 thru BJ8 to (c)26704

ill.	Part Number	Price €ea.	Description	Req.	Details
98	GHF333	€0.72	WASHER, locking	4	
	100	NA	HUB ASSEMBLY, disc wheels	2	BN4, BN6
	101 1G7435	€3.72	STUD, wheel, disc wheels	10	
		NA	HUB ASSEMBLY, disc wheels	2	BN7, BT7, BJ7, BJ8 to (c)26704
	ATC4257	NA	STUD, wheel, disc wheels	10	BJ8 from (c)26705
		NA	HUB ASSEMBLY, disc wheels	2	
	AUC2118	€2.04	STUD, wheel, disc wheels	10	
	102 88G275	€5.64	NUT, wheel stud, disc wheels	10	BN4 thru BJ8
	1B4320	€135.36	HUB, wire wheel, front, RH (Uses ball bearings)	1	
	1B4321	€135.36	HUB, wire wheel, front, LH	1	BN1 (some late BN1 used BN2 hubs)
	106 662-101	€7.44	STUD, hub to brake drum	8	
	107 662-102	€6.84	NUT, self-locking	8	
	110 1B4478	€140.40	HUB, wire wheel, front, RH (Uses tapered roller bearings)	1	BN2, BN4, BN6 (also a few late BN1)
		NA	HUB, wire wheel, front, LH	1	
	111 1B4416	€15.00	STUD, hub to brake drum	8	
	112 FNZ507	€1.68	NUT	8	
	BTC108	€147.96	HUB, wire wheel, front, RH (hubs are 12 tpi thread)	1	BN7, BT7, BJ7, BJ8 to (c)26704
	BTC109	€147.96	HUB, wire wheel, front, LH	1	
	113 BTC103	€6.12	STUD, hub to brake disc	10	
	114 662-025	€1.56	NUT, self-locking	10	
	BTC390	€148.56	HUB, wire wheel, front, RH	1	BJ8 from (c)26705 (hubs are 8 tpi thread)
	BTC391	€148.56	HUB, wire wheel, front, LH	1	
	53K1048	€1.20	BOLT, hub to brake disc	10	
	GHF202	€0.72	NUT	10	
	115 GHF334	€1.32	WASHER, locking	8	BN2, BN4, BN6
	GHF333	€0.72	WASHER, locking	10	BJ8 to (c) 26704
	118 GHS103	€3.24	SEAL, oil	2	(all)
	119 217325A	€26.04	BEARING, hub, inner	2	BN1 (ball bearings)
	120 GHB126	€31.44	BEARING, hub, outer	2	
	121	NA	SPACER, bearing	2	
	GHB105	€14.64	BEARING, hub, inner (tapered roller bearings)	2	BN2; BN4, BN6 wire wheels
	GHB182	€50.88	BEARING, hub, outer	2	
		NA	SPACER, bearing	2	
	217325A	€26.04	BEARING, hub, inner	2	BN4, BN6 disc wheels
	021-200	€45.72	BEARING, hub, outer	2	
	031-389	€24.72	SPACER, bearing	2	
	GHB105	€14.64	BEARING, hub, inner	2	BN7, BT7, BJ7, BJ8 to (c) 26704 wire & disc wheels
	GHB182	€50.88	BEARING, hub, outer	2	
	031-389	€24.72	SPACER, bearing	2	
	GHB105	€14.64	BEARING, hub, inner	2	BJ8 from (c)26705 wire & disc wheels
	GHB102	€21.72	BEARING, hub, outer	2	
	88G484	€12.96	SPACER, bearing	2	
	122 263-145	€2.88	SHIM, .003	A/R	BN1, BN2, BN4, BN6,
	263-155	€2.88	SHIM, .005	A/R	BN7, BT7, BJ7, BJ8 to
	263-165	€2.52	SHIM, .010	A/R	
	263-175	€2.88	SHIM, .030	A/R	
	263-508	€11.40	SHIM KIT	1	
			(Kit includes 2 ea. 0.030", 0.010", and 4 ea. 0.005", 0.003" shims.)		
	ATB4240	€1.56	SHIM, .003	A/R	
	ATB4241	€1.56	SHIM, .005	A/R	BJ8 from (c)26705
	ATB4242	€1.56	SHIM, .010	A/R	
	BTB656	€1.56	SHIM, .030	A/R	
	123	NA	NUT, bearing retaining, BSF	2	BN1 to C.E.221403
	53K330	€7.56	NUT, bearing retaining, UNF	2	BN1 from C.E.221404, BN2, BN4, BN6, BN7, BT7, BJ8
	124 1A4742	€2.16	LOCKWASHER	2	
	125 GHF504	€1.08	SPLIT PIN	2	
	126 031-391	NA	CUP, grease retaining	2	BN4, BN6 disc wheels
	ATB4098	€10.92	CUP, grease retaining	2	BN7, BT7, BJ7, BJ8 disc whls.
	127 1B4316	€18.24	CUP, grease retaining	2	BN1, BN2, BN4, BN6, BN7, BT7, BJ7, BJ8 to (c)26704 wire whls.
	BTC392	€5.04	CUP, grease retaining	2	BJ8 from (c)26705 wire whls
	130	NA	WHEEL SPINNER	2	See page 75.

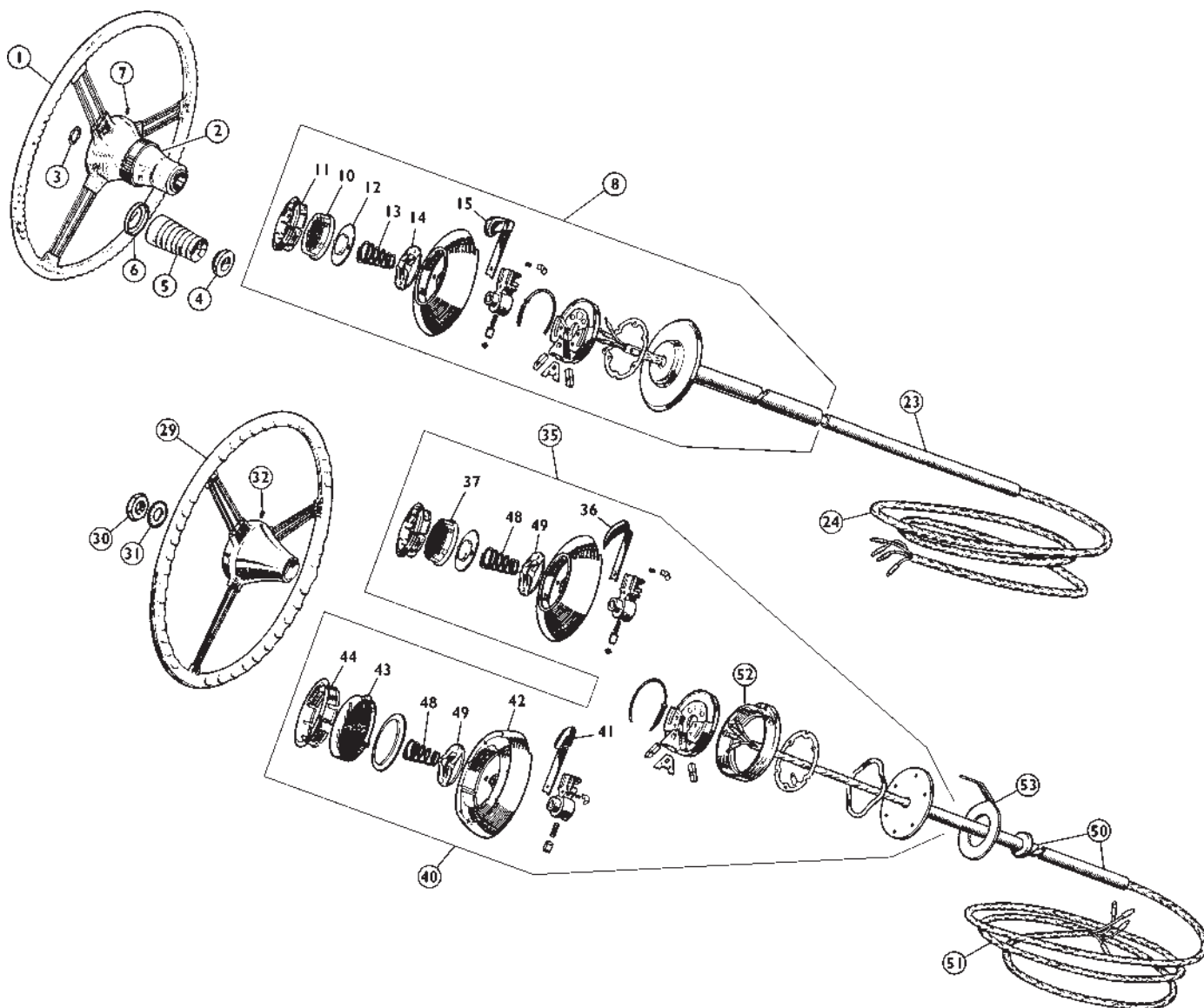

Part Number	Price €ea.	Description	Req.	Details
Steering Wheels; Control Heads				
Adjustable Steering				
1	853-715	NA STEERING WHEEL, adjustable	1	BN1 to C.E.149929
2		NA NUT, clamping	1	LHD & 149949 RHD
	1B6299	€579.60 STEERING WHEEL, adjustable	1	BN4, BN6, BN7, BT7,
	1B6300	€114.24 NUT, clamping	1	BJ7, BJ8
3	326-095	€3.48 RING, spring	1	
4	667-660	€8.52 SUPPORT, dust cover	1	
5	1D6163	€45.96 SPRING COVER	1	
6	667-670	€13.32 CUP, dust cover	1	
		NA SCREW, retaining stator tube	2	BN1 to C.E.149929
	021-245	NA CONTROL HEAD ASSEMBLY	1	LHD, 149949 RHD
	021-243	NA HORN PUSH	1	
7	059107	€2.52 SCREW, retaining stator tube	3	BN4, BN6, BN7, BT7, BJ7, BJ8 adjustable wheel only
8	1B6303	€462.00 CONTROL HEAD ASSEMBLY	1	
10		NA HORN PUSH	1	
11		NA RING, horn push retaining	1	
12		NA CONTACT PLATE, horn push	1	
13		NA SPRING, horn push	1	
14		NA CONTACT, horn push	1	
15		NA LEVER, turn signal	1	BN4 thru BJ8 adjustable whl.
	021-242	€39.96 LEVER, turn signal	1	BN1 adjustable wheel
23	021-247	€45.72 STATOR TUBE	1	BN4 thru BJ8 adjustable whl.
24	502355	€59.52 HARNESS (included with control heads)	1	

Part Number	Price €ea.	Description	Req.	Details
Non-Adjustable Steering				
29	853-690	NA STEERING WHEEL, non-adjustable	1	17"
	8G624	NA STEERING WHEEL, non-adjustable	1	16-1/2"
All BN1, BN2, and BN4 with non-adjustable steering used the 17" wheel. For later cars, both wheels were available as alternates. Either wheel fits all.				
30	2K6057	€15.00 NUT, steering wheel	1	non-adjustable steering
31		NA WASHER, shakeproof	1	
32		NA SCREW, retaining stator tube	2/3	
35		NA CONTROL HEAD ASSEMBLY	1	RHD & 149930 LHD, BN2 BN1 from C.E.149950
Not available. Later unit #1B6346 may be used as replacement.				
36	021-242	€39.96 LEVER, turn signal	1	
37	021-243	NA HORN PUSH	1	
40	1B6346	€1,369.20 CONTROL HEAD ASSEMBLY	1	
41		NA LEVER, turn signal	1	BN4 thru BJ8 non adjustable wheels only
42	021-248	NA MOULDING, top cover	1	
43	021-249	NA HORN PUSH	1	
44	021-239	NA RING, horn push retaining	1	
48		NA SPRING, horn push	1	
49		NA CONTACT, horn push	1	
50	7H5140	€61.92 STATOR TUBE	1	non-adjustable wheels
51	502355	€59.52 HARNESS (included with control heads)	1	
52	021-241	€81.72 STRIKER RING	1	
53	021-244	€28.80 CANCELLING ARM	1	

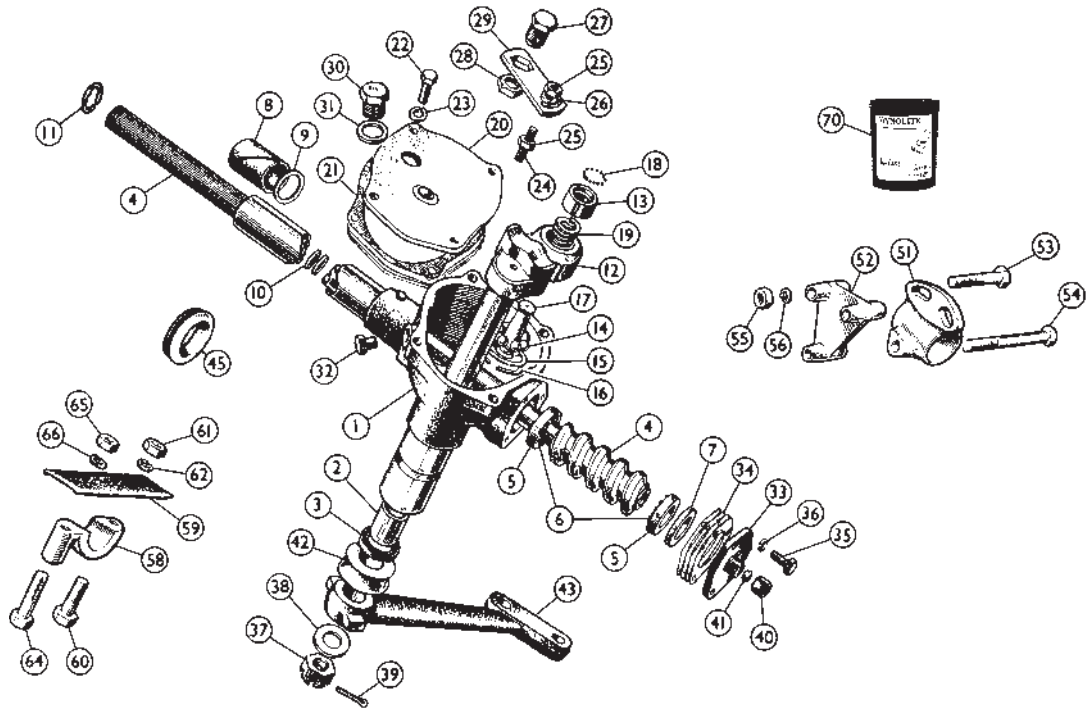

iii.	Part Number	Price €ea.	Description	Req.	Details	iii.	Part Number	Price €ea.	Description	Req.	Details
Steering Box BN1, early BN2											
BN1, BN2 to C.E.231108(LHD), 230977(RHD)											
1	NA		STEERING BOX ASSY, LHD	1	adjustable steering	30	NA		PLUG, oil, in top cover	1	
	NA		STEERING BOX ASSY, RHD	1		31	NA		WASHER, plug	1	
	NA		STEERING BOX ASSY, LHD	1	non-adjustable steering to C.E.219257	32	NA		PLUG, oil, in steering box body	1	
	NA		STEERING BOX ASSY, RHD	1	non-adjustable steering to C.E.219136	33	NA		COVER, end	1	
	NA		STEERING BOX ASSY, LHD	1	non-adjustable steering C.E.219258 to C.E.231108	34	260-045		GASKET, end cover, .005"	A/R	
	NA		STEERING BOX ASSY, RHD	1	non-adjustable steering C.E.219137 to C.E.230977	35	260-055		GASKET, end cover, .002"	A/R	
2	667-680	€49.92	BUSH	1		36	GHF332	€0.84	WASHER, locking	3	
3	501563	€4.32	SEAL, oil	1		37	NA		NUT, lever to gear	1	
4			NA COLUMN, with cam, LHD	1	adjustable steering	38	NA		WASHER, plain	1	
			NA COLUMN, with cam, RHD	1		39	GHF504	€1.08	SPLIT PIN	1	
	667-635		NA COLUMN, with cam, LHD	1	non-adjustable steering	40	103611	€12.60	NUT, stator tube	1	
			NA COLUMN, with cam, RHD	1		41	501575	€4.56	OLIVE	1	
5	667-645	€38.88	CUP, ball cage	2		42	27H6995	€2.16	COVER, dust, oil seal	1	
6	BLS107	€0.84	BALL, 7/32"	28		43			NA LEVER, steering, LHD	1	
7			NA WASHER, lower race	1			667-650	€244.80	LEVER, steering, RHD	1	
8	667-655		NA BUSH, felt	1	adjustable steering	45	3H2506	€2.64	GROMMET, steering column	1	
9			NA WASHER	1		51	NA		BRACKET, steering box	1	
	667-655		NA BUSH, felt	1	non-adjustable steering	52	NA		SPACER, bracket	2	
			NA WASHER	1		53	NA		BOLT, bracket to body, short	2	
10			NA WASHER, anti-rattle, rubber	2	adjustable steering	54	NA		BOLT, bracket to body, long	1	
11	326-095	€3.48	CIRCLIP	1		55	AJD8106Z	€0.96	NUT, BSF	3	
12	667-675		NA SHAFT, rocker	1		56	GHF333	€0.72	WASHER, locking	3	
13	667-695		NA CUP, ball	1		58	667-825	€33.12	CLAMP PAIR, steering column support	1	
14	BLS112	€0.96	BALL, 3/8"	8		59	667-795	€4.08	PACKING PIECE, rubber	1	
15			NA WASHER, retaining, dished	1		60	BH604181	€1.44	BOLT, clamp, short	1	
16			NA CIRCLIP	1		61	GHF200	€0.96	NUT for short bolt	1	
17	667-035	€318.00	PEG, for rocker shaft	1		62	GHF331	€0.84	WASHER, locking, for short bolt	1	
18	BLS105	€1.08	BALL, 5/32"	13		64	BH604221	€1.44	BOLT, clamp, long	1	
19	667-705		NA SPRING, for peg	1		65	GHF200	€0.96	NUT for long bolt	1	
20			NA COVER, top, with button, LHD	1	adjustable steering; non-adj. to C.E.219257	66	GHF331	€0.84	WASHER, locking, for long bolt	1	
			NA COVER, top, with button, RHD	1	adjustable steering; non-adj. to C.E.219137	70	GGL843110	€13.92	DYNOLITE SEMI FLUID GREASE	1	
			NA COVER, top, LHD	1	non-adj. steering from C.E.219258						
			NA COVER, top, RHD	1	non-adj. steering from C.E.219137						
21	260-015		NA SHIM, top cover, .010"	A/R							
	260-025		NA SHIM, top cover, .005"	A/R							
	260-035		NA SHIM, top cover, .002"	A/R							
22			NA BOLT, top cover	3/4							
23	GHF332	€0.84	WASHER, locking	4							
24			NA STUD, top cover & lockplate	1	BN1 from C.E.219137						
25			NA NUT	2	RHD & 219258 LHD, BN2 to C.E.230977 RHD, 231108 LHD						
26	WP9	€2.04	WASHER, plain	1							
27			NA BOLT, thrust	1							
28			NA NUT, lock	1							
29			NA LOCKPLATE, thrust screw	1							

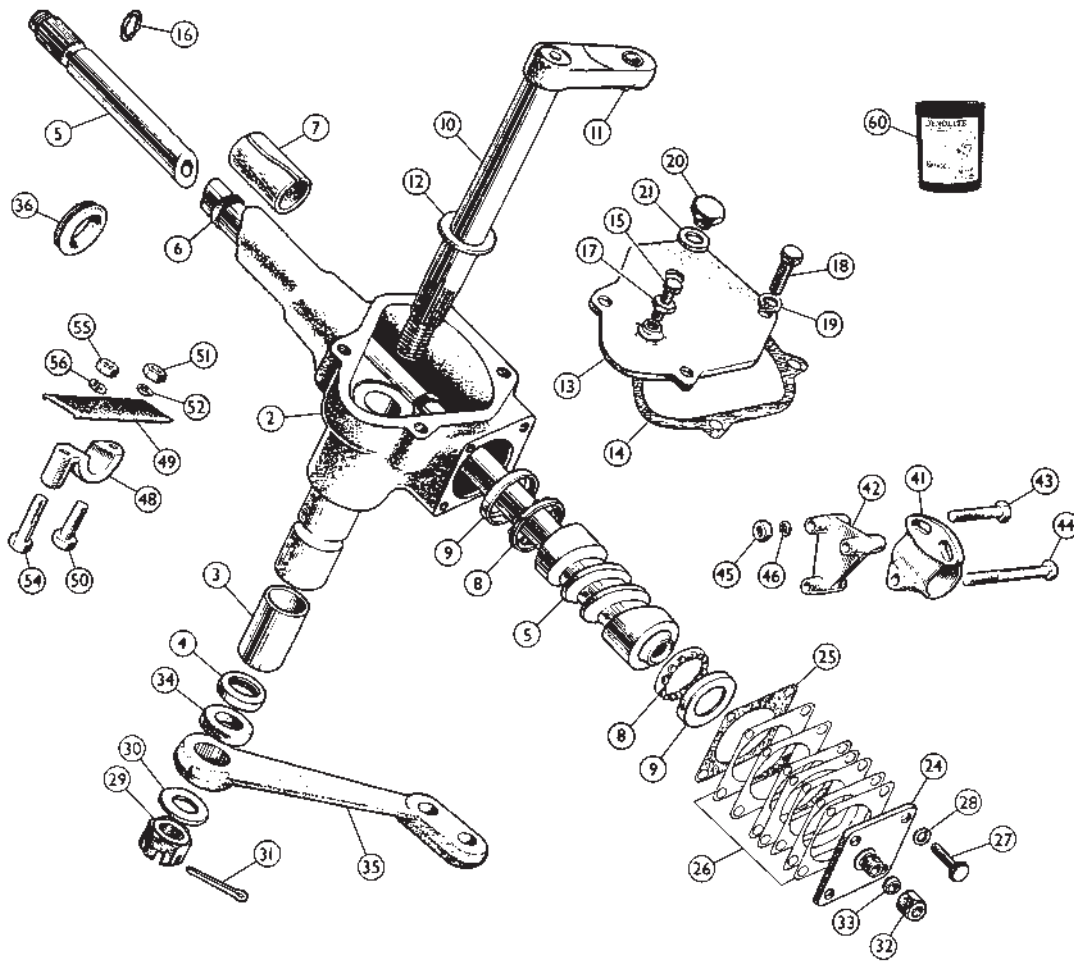

ill.	Part Number	Price €ea.	Description	Req.	Details
Steering Box late BN2, early BN4/BN6					
BN2 from C.E.231109(LHD), 230978(RHD);					
BN4 to C.E.68959; BN6 to (c)1994					
2			NA STEERING BOX ASSY, LHD	1	adjustable BN4
			NA STEERING BOX ASSY, RHD	1	
			NA STEERING BOX ASSY, LHD	1	non-adjustable BN2, BN6
			NA STEERING BOX ASSY, RHD	1	
			NA BOX & OUTER COLUMN, LHD	1	non-adjustable BN6
			NA BOX & OUTER COLUMN, RHD	1	
3	1B6257	€9.12	BUSH	1	
4	7H6589	€5.28	SEAL, oil	1	
5			NA COLUMN, with cam, LHD	1	adjustable BN4
			NA COLUMN, with cam, RHD	1	
			NA COLUMN, with cam, LHD	1	non-adjustable BN2, BN6
			NA COLUMN, with cam, RHD	1	
6	060586		NA RING, rubber	2	
7	AHA5893	€3.96	BUSH, felt	1	
8	7H6079	€33.96	CAGE ASSEMBLY, ball	2	
9	7H6116	€31.32	CUP, ball cage	2	
10	031-261		NA SHAFT, rocker	1	
11	667-620	€121.08	PEG, for rocker shaft	1	
12	725-115	€6.00	WASHER, Belleville	6	
13			NA COVER, top, LHD	1	
			NA COVER, top, RHD	1	
14	697-410		NA GASKET, top cover	1	BN4
15	667-155		NA BOLT, thrust	1	BN2
	667-165		NA BOLT, thrust	1	BN4, BN6
16	326-095	€3.48	CIRCLIP	1	adjustable column
17			NA NUT, lock	1	BN4
18			NA BOLT, top cover	4	BN2
	GHF120	€0.72	BOLT, top cover, 3/4"	4	BN4, BN6
19	GHF332	€0.84	WASHER, locking	4	
20	031-263	€9.48	PLUG, oil	1	
21	ARR1499	€1.20	WASHER, plug	1	
24	667-835	€38.28	COVER, end	1	
25	060370	€1.44	GASKET, end cover	1	

ill.	Part Number	Price €ea.	Description	Req.	Details
26	060367	€2.04	SHIM, .0024"	A/R	
	060368	€2.16	SHIM, .005"	A/R	
	060369	€2.40	SHIM, .010"	A/R	
27	GHF120	€0.72	BOLT, end cover	4	
28	GHF332	€0.84	WASHER, locking	4	
29	725-110	€6.84	NUT, lever to gear	1	
30			NA WASHER, plain	1	
31	GHF506	€1.20	SPLIT PIN	1	
32	103611	€12.60	NUT, stator tube	1	
33	501575	€4.56	OLIVE	1	
34	27H6995	€2.16	COVER, dust, oil seal	1	
35	031-265	€391.20	LEVER, steering, LHD	1	
	667-650	€244.80	LEVER, steering, RHD	1	
36	3H2506	€2.64	GROMMET, steering column	1	
41	667-805		NA BRACKET, steering box	1	
42	667-790	€37.80	SPACER, bracket	2	
43			NA BOLT, bracket to body, short	2	
44			NA BOLT, bracket to body, long	1	BN2
45	AJD8106Z	€0.96	NUT, BSF	3	
	BH606261	€2.76	BOLT, bracket to body, short	2	
			NA BOLT, bracket to body, long	1	BN4, BN6
	GHF202	€0.72	NUT, UNF	3	
46	GHF333	€0.72	WASHER, locking	3	
48	667-825	€33.12	CLAMP PAIR, steering column support	1	
49	667-795	€4.08	PACKING PIECE, rubber	1	
50	BH604181	€1.44	BOLT, clamp, short	1	
51	GHF200	€0.96	NUT for short bolt	1	
52	GHF331	€0.84	WASHER, locking, for short bolt	1	
54	BH604221	€1.44	BOLT, clamp, long	1	BN2
	BH605241	€2.40	BOLT, clamp, long	1	BN4, BN6
55	GHF200	€0.96	NUT for long bolt	1	BN2
	GHF201	€0.84	NUT for long bolt	1	BN4, BN6
56	GHF331	€0.84	WASHER, locking	1	BN2
	GHF332	€0.84	WASHER, locking	1	BN4, BN6
60	GGL843110	€13.92	DYNOLITE SEMI FLUID GREASE	1	

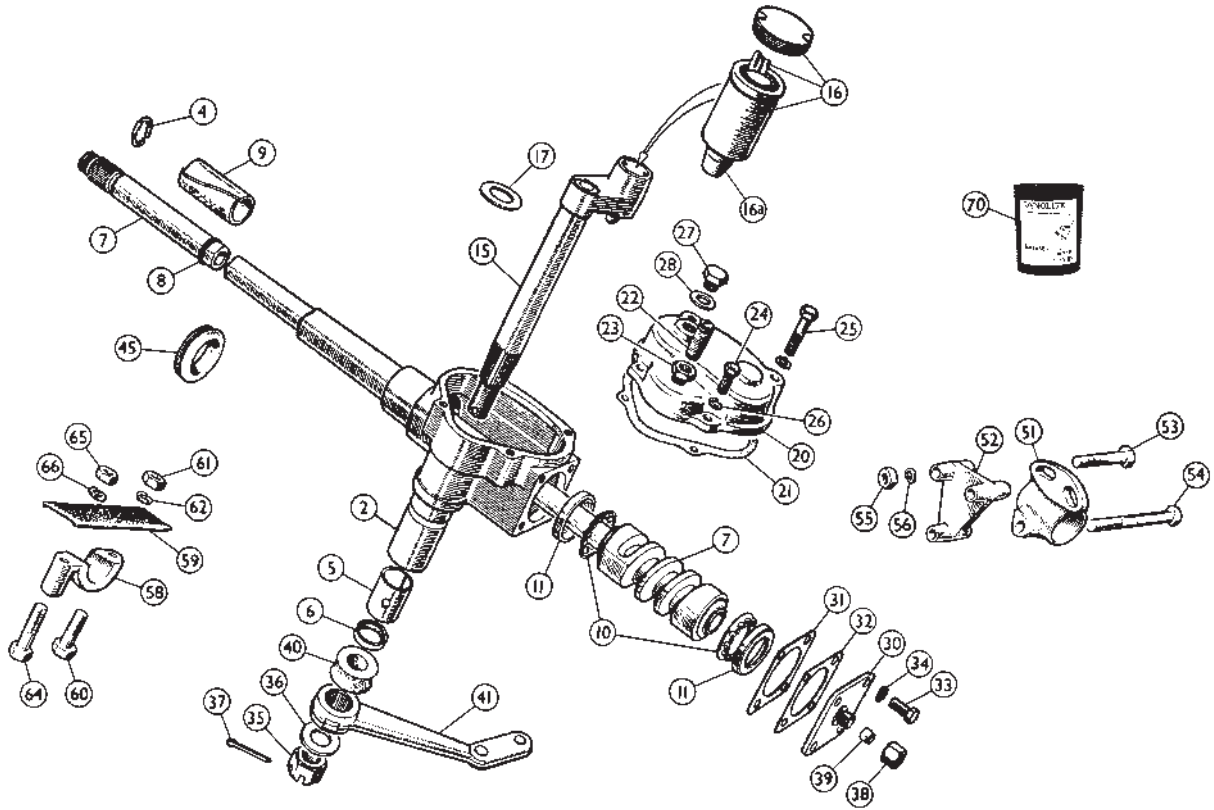

ill. Part Number Price €ea. Description Req. Details

Steering Box late BN4/BN6, BN7/BT7, BJ7, BJ8

BN4 from C.E.68960; BN6 from (c)1995; BN7, BT7, BJ7, BJ8

ill. Part Number Price €ea. Description Req. Details

Note: a very small number of LHD vehicles fitted with this late type steering box were also fitted with steering locks.

Part Number	Price €ea.	Description	Req.	Details
667-830	€2,085.60	STEERING BOX ASSY, LHD, std. ratio	1	adjustable steering
667-831	€1,927.20	STEERING BOX ASSY, LHD, high ratio	1	
NA		STEERING BOX ASSY, RHD	1	
		Standard ratio is 3.5 turns lock to lock, high ratio is 2.5 turns.		
2		NA STEERING BOX ASSEMBLY, LHD	1	non-adjustable steering
		NA STEERING BOX ASSEMBLY, RHD	1	
		NA BOX & OUTER COLUMN, LHD	1	adjustable steering
		NA BOX & OUTER COLUMN, RHD	1	
		NA BOX & OUTER COLUMN, LHD	1	non-adjustable steering
		NA BOX & OUTER COLUMN, RHD	1	
		NA BOX & OUTER COLUMN, LHD	1	non-adjustable steering
		NA BOX & OUTER COLUMN, RHD	1	
4	€3.48	CIRCLIP	1	
5	€9.12	BUSH	1	
6	€5.28	SEAL, oil	1	
7	€547.20	COLUMN, with cam, LHD	1	adjustable steering
		NA COLUMN, with cam, RHD	1	
	€457.20	COLUMN, with cam, LHD	1	non-adjustable steering
		NA COLUMN, with cam, RHD	1	
		NA COLUMN, with cam, RHD	1	non-adjustable steering
		NA COLUMN, with cam, RHD	1	
8	NA	RING, rubber	2	
9	€3.96	BUSH, felt	1	
10	€33.96	CAGE ASSEMBLY, ball	2	
11	€31.32	CUP, ball cage	2	
15	€518.40	SHAFT, rocker	1	
16	NA	ROLLER ASSEMBLY	1	
16a	€36.96	PEG	1	
17	€6.00	WASHER, belleville	6	
20	NA	COVER, top, LHD	1	
	NA	COVER, top, RHD	1	
21	€1.20	GASKET, top cover	1	
22	NA	BOLT, thrust	1	
23	NA	NUT, lock	1	
24	€0.72	BOLT, top cover, 3/4"	2	

ill. Part Number Price €ea. Description Req. Details

25	GHF104	€1.20	BOLT, top cover, 1-1/2"	2
26	GHF332	€0.84	WASHER, locking	4
27	031-263	€9.48	PLUG, oil	1
28	ARRH1499	€1.20	WASHER, plug	1
30	667-835	€38.28	COVER, end	1
31	060370	€1.44	GASKET, end cover	1
32	060367	€2.04	SHIM, .0024"	A/R
	060368	€2.16	SHIM, .005"	A/R
	060369	€2.40	SHIM, .010"	A/R
33	GHF120	€0.72	BOLT, end cover	4
34	GHF332	€0.84	WASHER, locking	4
35	725-110	€6.84	NUT, lever to gear	1
36	324-615	NA	WASHER, plain	1
37	GHF506	€1.20	SPLIT PIN	1
38	103611	€12.60	NUT, stator tube	1
39	501575	€4.56	OLIVE	1
40	27H6995	€2.16	COVER, dust, oil seal	1
41	031-265	€391.20	LEVER, steering, LHD	1
	667-650	€244.80	LEVER, steering, RHD	1
45	3H2506	€2.64	GROMMET, steering column	1
51	667-805	NA	BRACKET, steering box	1
52	667-790	€37.80	SPACER, bracket	2
53	BH606261	€2.76	BOLT, bracket to body, short	2
	NA		BOLT, bracket to body, long	1
55	GHF202	€0.72	NUT, UNF	3
56	GHF333	€0.72	WASHER, locking	3
58	667-825	€33.12	CLAMP PAIR, steering column support	1
59	667-795	€4.08	PACKING PIECE, rubber	1
60	BH604181	€1.44	BOLT, clamp, short	1
61	GHF200	€0.96	NUT for short bolt	1
62	GHF331	€0.84	WASHER, locking, for short bolt	1
64	BH605241	€2.40	BOLT, clamp, long	1
65	GHF201	€0.84	NUT for long bolt	1
66	GHF332	€0.84	WASHER, locking, for long bolt	1
70	GGL843110	€13.92	DYNOLITE SEMI FLUID GREASE	1

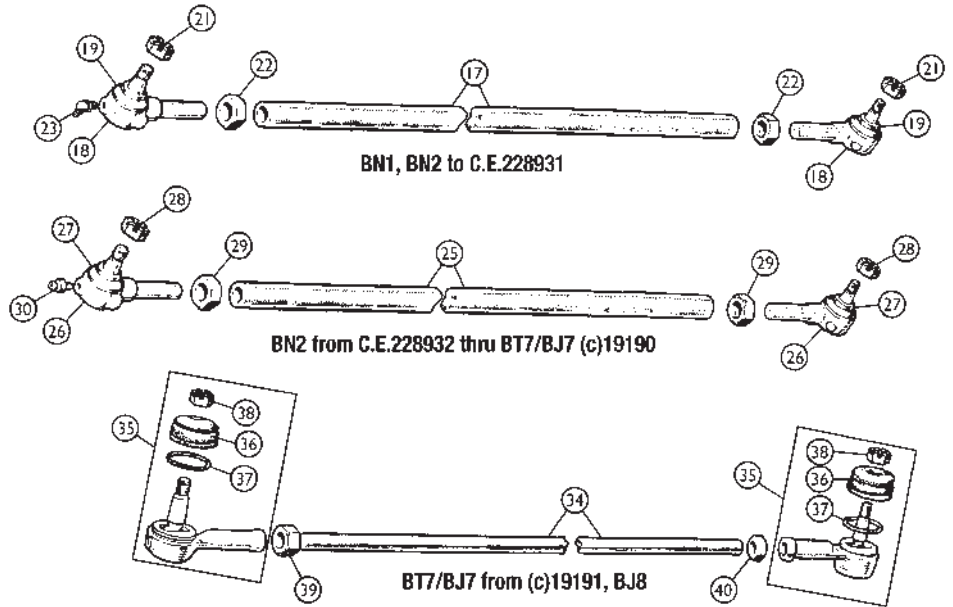
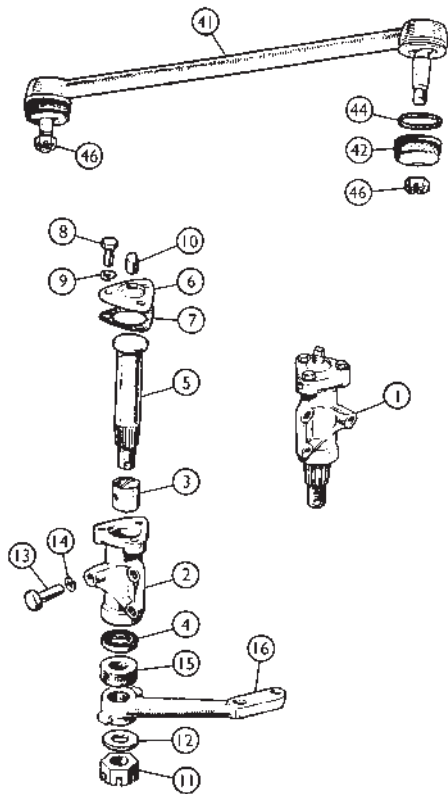

ill. Part Number Price €ea. Description

Steering Idlers; Crossrods

Idler Assemblies

QTY	Part Number	Price €ea.	Description	Req.	Details
1	667-640	NA	IDLER ASSEMBLY, LHD	1	
		NA	IDLER ASSEMBLY, RHD	1	
2		NA	BODY, idler, LHD	1	
		NA	BODY, idler, RHD	1	
3	501562	€6.12	BUSH	2	
4	501563	€4.32	SEAL, oil	1	
5	667-690	NA	SHAFT, idler	1	
6	667-575	NA	COVER	1	
7	697-430	€1.08	GASKET, cover	A/R	BN1, BN2 to C.E.231108 LHD & 230978 RHD
8		NA	BOLT, cover	3	
9	GHF332	€0.84	WASHER, locking	3	
10		NA	PLUG, filler	1	
11		NA	NUT, idler shaft	1	
12		NA	WASHER, plain	1	
13		NA	BOLT, idler gear to chassis	3	
14	GHF333	€0.72	WASHER, locking	3	
15	27H6995	€2.16	COVER, dust, oil seal, rubber	1	
16		NA	LEVER, idler gear, LHD	1	
	667-650	€244.80	LEVER, idler gear, RHD	1	
1	667-565	€264.00	IDLER ASSEMBLY, LHD	1	
		NA	IDLER ASSEMBLY, RHD	1	
2		NA	BODY, idler, LHD	1	
		NA	BODY, idler, RHD	1	
3	1B6257	€9.12	BUSH	2	
4	132292	€5.16	SEAL, oil	1	
5	667-700	€100.56	SHAFT, idler	1	
6	667-575	NA	COVER	1	
7	697-430	€1.08	GASKET, cover	A/R	BN2 from C.E.231109 LHD & 230979 RHD,
8	GHF120	€0.72	BOLT, cover	3	BN4, BN6, BN7, BT7, BJ7, BJ8
9	GHF332	€0.84	WASHER, locking	3	
10		NA	PLUG, filler	1	
11	725-110	€6.84	NUT, idler shaft	1	
12		NA	WASHER, plain	1	
13	GHF126	€2.64	BOLT, idler gear to chassis	3	
14	GHF333	€0.72	WASHER, locking	3	
15	27H6995	€2.16	COVER, dust, oil seal, foam	1	
16	667-650	€244.80	LEVER, idler gear, LHD	1	
	031-265	€391.20	LEVER, idler gear, RHD	1	

Req. Details

ill. Part Number Price €ea. Description

Cross Rods

QTY	Part Number	Price €ea.	Description	Req.	Details
1	NA		CROSS ROD ASSEMBLY	1	BN1 to C.E.157623
<p>Note: BN1 models up to C.E.157623 originally used a cross rod assembly with adjustable ball pins. This has been superceded by the later assembly, 667-585.</p>					
	667-585	NA	CROSS ROD ASSEMBLY, w/ ends	1	
18	QHQR20	€37.80	TRACK ROD END, replacement	1	
19	7H3762	€6.00	COVER, dust, original style	2	
		NA	COVER, dust, replacement	2	
		NA	RING, spring, original style	2	
	7H3565	€4.32	RING, spring, replacement	2	BN1, BN2 to C.E.22893
21		NA	NUT, ball pin, original style	2	
	NL607041	€2.88	NUT, ball pin, replacement	2	
22		NA	NUT, locking, RH thread	1	
		NA	NUT, locking, LH thread	1	
23	UHN445	€2.64	NIPPLE, grease, 45 degree angle	2	
25	667-595	NA	CROSS ROD ASSEMBLY, w/ ends	1	
26	SC1207	€33.60	TRACK ROD END, replacement	1	
27		NA	COVER, dust, original style	2	
	7H3762	€6.00	COVER, dust, replacement	2	BN2 from C.E.228932,
	7H3565	€4.32	RING, spring, replacement	2	BN4, BN6, BN7, BT7/ BJ7 to (c)19190
28	NL607041	€2.88	NUT, ball pin	2	
29	53K320	€2.76	NUT, locking, RH thread	1	
	101669	€4.56	NUT, locking, LH thread	1	
30	UHN400	€1.56	NIPPLE, grease, straight	2	
34	667-735	€75.48	CROSS ROD ASSEMBLY, w/ ends	1	
35	QHQR139	€30.60	TRACK ROD END, replacement	1	
36	262-225	€3.24	COVER, dust, original style	2	
	7H3762	€6.00	COVER, dust, replacement	2	BT7/BJ7 from (c)19191, BJ8
37		NA	RING, spring, original style	2	
	7H3565	€4.32	RING, spring, replacement	2	
38	NL607041	€2.88	NUT, ball pin	2	
39	NT610041	€1.92	NUT, locking, RH thread	1	
40	310-495	€5.16	NUT, locking, LH thread	1	

Req. Details

Side Rods

QTY	Part Number	Price €ea.	Description	Req.	Details
41		NA	SIDE ROD ASSEMBLY*	2	BN1 to C.E.157623
		NA	SIDE ROD ASSEMBLY*	2	BN1 from C.E.157624, BN2 to C.E.228931
	667-550	€84.60	SIDE ROD ASSEMBLY	2	BN2 from C.E.228932, BN4, BN6, BN7, BT7, BJ7, BJ8
42	7H3762	€6.00	COVER, dust	4	BN1 to BT7/BJ7 (c)19190
	262-225	€3.24	COVER, dust	4	BT7/BJ7 from (c)19191, BJ8
44	7H3565	€4.32	RING, spring, replacement	4	
46	NL607041	€2.88	NUT, ball pin	4	

*Use latest type 667-550 as replacement.

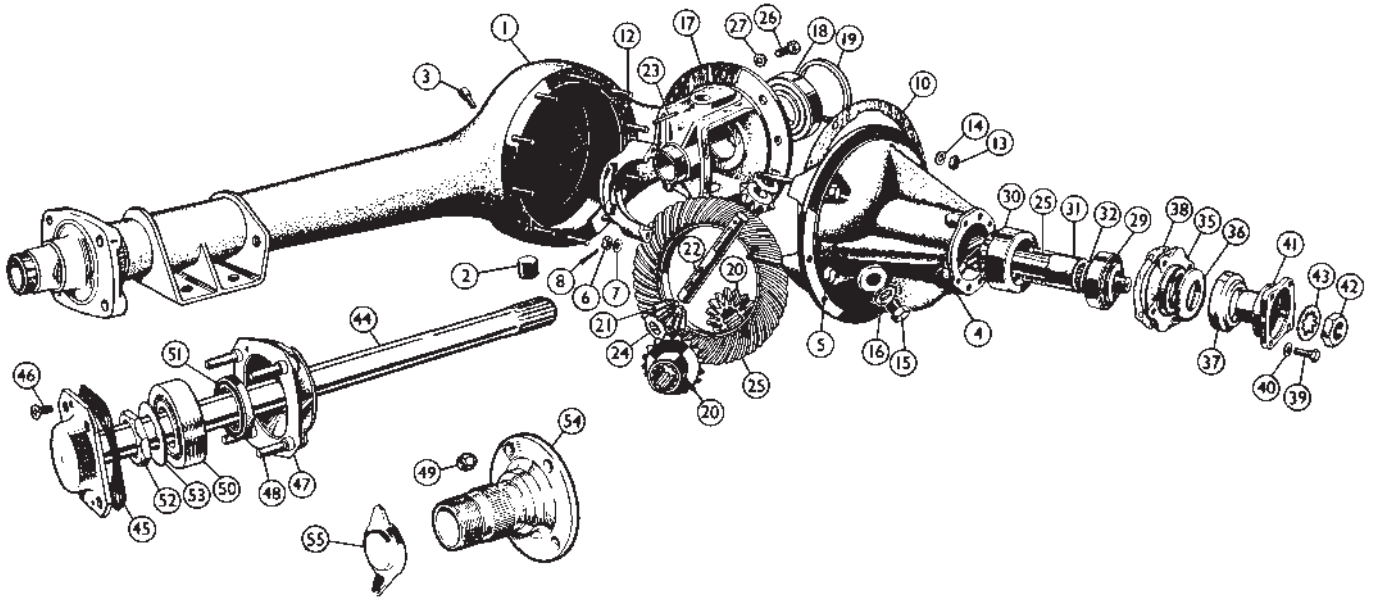

iii. Part Number Price €ea. Description Req. Details

Rear Axle early BN1 spiral bevel type

Earlier BN1 series cars used the spiral bevel type axle described here, whereas later BN1s used the hypoid type shown overleaf. The most blatant distinguishing feature of the spiral bevel axle is that each wheel hub contains four studs, rather than the later five.

Part Number	Price €ea.	Description	Req.	Details
1	NA	REAR AXLE ASSEMBLY	1	
2	6K499	€4.08 PLUG, drain	1	
3	21H6060	€6.12 VALVE, breather	1	
4	NA	CARRIER, gear	1	
5	NA	BOLT, bearing cap	4	
6	NA	NUT	4	
7	GHF303	€0.72 WASHER, plain	4	
8	GHF502	€1.08 SPLIT PIN	4	
10	293-110	€4.92 GASKET	1	
12	NA	STUD, for carrier	10	
13	AJD8105Z	€0.72 NUT	10	
14	GHF332	€0.84 WASHER, locking	10	
15	AEK122	€12.60 PLUG, filler	1	
16	AAA836	€1.56 WASHER	1	
17	NA	CARRIER, differential	1	
18	CHM163	€33.72 BEARING, carrier	2	
19	2K7993	€2.88 SHIM, bearing packing, .002"	A/R	
	2K7435	€2.88 SHIM, bearing packing, .004"	A/R	
	6K503	€2.88 SHIM, bearing packing, .006"	A/R	
20	NA	GEAR, differential, (16 teeth)	2	
	NA	GEAR, differential, (17 teeth)	2	
21	NA	PINION, differential, (10 teeth)	2	use with 16 tooth gear
	NA	PINION, differential, (10 teeth)	2	use with 17 tooth gear
22	NA	PIN, pinion	1	
23	6K842	NA PEG, pinion axle	1	
24	NA	THRUST WASHER	2	
25	NA	CROWN WHEEL & PINION	1	8/33, (4.125 to 1)
	NA	CROWN WHEEL & PINION	1	9/33, (3.666 to 1)
26	NA	SCREW, ring gear to case	8	
27	NA	WASHER, locking	4	
29	2A7213	€31.20 PINION BEARING, front	1	
30	100897A	€36.60 PINION BEARING, rear	1	
	100897TIM	€163.20 PINION BEARING, rear, Timken brand	1	
31	1B7240	€60.36 SPACER	1	
32	675-300	NA SHIM, bevel pinion, .003"	A/R	
	675-310	NA SHIM, bevel pinion, .005"	A/R	
35	NA	HOUSING, oil seal	1	
36	520-310	€9.48 SEAL, oil	1	
37	NA	DUST COVER, oil seal	1	
38	697-470	€4.08 GASKET, housing to carrier	1	
39	NA	SCREW, housing to axle case	4	
40	GHF331	€0.84 WASHER, locking	4	
41	NA	FLANGE, propeller shaft	1	
42	311-290	NA NUT, bevel pinion	1	
43	NA	LOCKWASHER	1	
44	031-392	€519.60 SHAFT, axle	2	
45	293-105	€1.92 GASKET, axle shaft	2	
46	NA	SCREW, shaft to hub	2	
47	031-394	NA WHEEL HUB (bearing housing)	2	
48	675-400	€5.16 STUD, hub to extension	8	
49	1B7376	€8.28 NUT	8	
50	GHB127	€25.44 BEARING, wheel	2	

iii. Part Number Price €ea. Description Req. Details

51	GHS211	€4.92 SEAL, oil (2-3/4")	2	
52	1G7304	€22.20 NUT, octagonal	2	use wrench 386-338 below
53	1G7584	€3.12 LOCKWASHER	2	
54	664-030	€109.20 HUB EXTENSION, LH	1	
	664-020	€109.20 HUB EXTENSION, RH	1	
55	AHH7318	€40.80 WHEEL SPINNER, 2-eared, 12 tpi, LH	2	
	AHH7317	€40.80 WHEEL SPINNER, 2-eared, 12 tpi, RH	2	

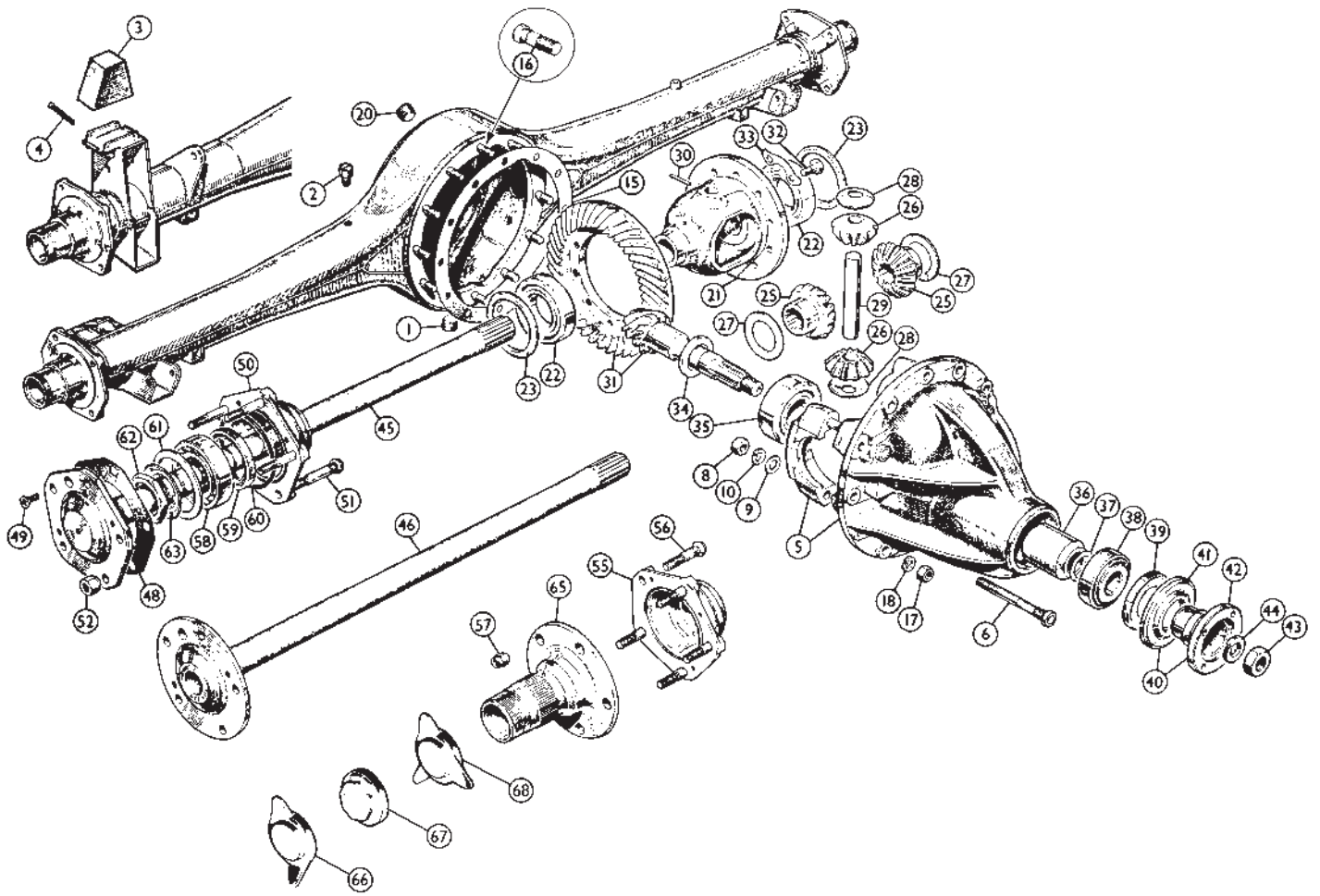

Part Number	Price €ea.	Description	Req.	Details
Rear Axle hypoid type				
		NA CASE, rear axle	1	BN1 from C.E.221536 to C.E.228011
		NA CASE, rear axle	1	BN1 from C.E.228012, thru BJ8 to (c)26704
		NA CASE, rear axle	1	BJ8 from (c)26705
1	€4.08	6K499 PLUG, drain	1	
2	€6.12	21H6060 VALVE, breather	1	
3	€6.60	2A7142 BUMP STOP, rear axle	2	BJ8 from (c)26705
4	€2.16	GHF513 SPLIT PIN, bump stop attachment	4	
		NA DIFFERENTIAL ASSY, 4.1 : 1	1	BN1 to C.E.228011
		NA DIFFERENTIAL ASSY, 4.1 : 1	1	BN1 from C.E.228012, BN2
		NA DIFFERENTIAL ASSY, 4.1 : 1	1	BN4, BN6 o/d
		NA DIFFERENTIAL ASSY, 3.909 : 1	1	BN4, BN6 non-o/d
		NA DIFFERENTIAL ASSY, 3.909 : 1	1	BN7-BJ8 o/d
		NA DIFFERENTIAL ASSY, 3.545 : 1	1	BN7-BJ8 non-o/d
5		NA CARRIER, gear	1	BN1 from C.E.221536 to C.E.228011
6		NA BOLT, bearing cap	3	
	€15.00	51K886 STUD, bearing cap	1	
		NA CARRIER, gear	1	BN1 from C.E.228012, BN2 thru BJ8
	€17.88	320-919 BOLT, bearing cap	4	
8	€0.72	GHF203 NUT	4	
		NA WASHER, plain	4	
10	€1.32	GHF334 WASHER, locking	4	
15	€2.16	ATC7124 GASKET	1	
16		NA BOLT, for carrier	12	
17	€0.72	GHF202 NUT	12	
18	€0.72	GHF333 WASHER, locking	12	
		NA PLUG, filler, in gear carrier	1	BN1 to C.E.228011
20	€4.08	6K499 PLUG, filler, in axle case	1	BN1 from C.E.228012, BN2-BJ8
21		NA CARRIER, differential	1	
22	€36.60	CHM162 BEARING, carrier	2	
23	€23.40	675-115 SHIM, bearing packing, .193"	A/R	
		675-120 NA SHIM, bearing packing, .191"	A/R	
		675-125 NA SHIM, bearing packing, .189"	A/R	
	€24.48	675-130 SHIM, bearing packing, .187"	A/R	
		675-140 NA SHIM, bearing packing, .185"	A/R	
	€25.44	675-150 SHIM, bearing packing, .183"	A/R	
		675-160 NA SHIM, bearing packing, .181"	A/R	
		675-170 NA SHIM, bearing packing, .179"	A/R	
	€24.24	675-180 SHIM, bearing packing, .177"	A/R	
		675-190 NA SHIM, bearing packing, .175"	A/R	
25		NA GEAR, differential, generated teeth	1	
	€51.00	ATC7262 GEAR, differential, revacycle	1	alternatives
26		NA PINION, differential, generated teeth	1	
		NA PINION, differential, revacycle	1	

Note: generated teeth types were fitted as an alternative to revacycle on some BN1, BN2 and BN4 models.

27		NA THRUST WASHER, gear	A/R	
28		ATC7104 NA THRUST WASHER, pinion	A/R	
29		NA PIN, pinion	1	
30	€1.80	675-285 PEG, pinion axle	1	
31		NA CROWN WHEEL & PINION 10/41, (4.1 to 1)	1	BN1, BN2, BN4, BN6 o/d
	€864.00	8G7131 CROWN WHEEL & PINION, 11/43, (3.909 to 1)	1	BN4, BN6 non-o/d
	€864.00	8G7131 CROWN WHEEL & PINION, 11/43, (3.909 to 1)	1	BN7-BJ8 o/d
	€864.00	031-284 CROWN WHEEL & PINION, 11/39, (3.545 to 1)	1	BN7, BT7, BJ7, BJ8 non-o/d
32	€5.88	ATA7043 BOLT, crown wheel to case	10	
33	€4.56	031-289 LOCKTAB	5	
34		NA WASHER, pinion thrust, .222"	1	
		675-220 NA WASHER, pinion thrust, .220"	1	
		675-230 NA WASHER, pinion thrust, .218"	1	
		675-240 NA WASHER, pinion thrust, .216"	1	use 1 of selected size
		675-250 NA WASHER, pinion thrust, .214"	1	
		675-260 NA WASHER, pinion thrust, .212"	1	
		675-270 NA WASHER, pinion thrust, .210"	1	
		675-280 NA WASHER, pinion thrust, .208"	1	
35	€81.36	ATC7089 PINION BEARING, rear	1	
36		675-290 NA SPACER	1	
37		675-320 NA SHIM, outer bearing, .004"	A/R	
		ATC7153 NA SHIM, outer bearing, .006"	A/R	
		675-340 NA SHIM, outer bearing, .008"	A/R	
	€7.44	675-350 SHIM, outer bearing, .010"	A/R	
		675-360 NA SHIM, outer bearing, .012"	A/R	
		675-370 NA SHIM, outer bearing, .020"	A/R	
	€7.44	675-380 SHIM, outer bearing, .030"	A/R	

Note: To determine which washer or shim thickness is required, the unit must be disassembled, and measurements made as outlined in the appropriate workshop manual.

38	€32.28	ATC7091 PINION BEARING, front	1	
39	€12.96	ATC7085 SEAL, oil	1	
40	€149.28	019-282 FLANGE & DUST COVER	1	
41		675-390 NA DUST COVER, oil seal	1	
42		031-282 NA FLANGE, propeller shaft	1	
43	€5.28	FNZ612 NUT, bevel pinion	1	
44	€1.20	WL600121 WASHER, locking	1	
45	€448.80	031-328 SHAFT, axle	2	BN1 from C.E.221536, BN2
46	€448.80	031-328 SHAFT, axle	2	BN4 - BJ8
48	€1.44	GFG112 GASKET, axle shaft	2	
49	€0.96	SF604041 SCREW, shaft to hub	2	

Part Number	Price €ea.	Description	Req.	Details
50		NA HUB, disc wheel only	2	BN4, BN6
		NA HUB, disc wheel only	2	BN7-BJ8
51	675-410	NA STUD, disc wheel	10	BN4-BJ8
52	88G275	€5.64 NUT, disc wheel	10	
55		NA HUB, wire wheel only	2	BN1 from C.E.221536, to C.E.228011
56		NA STUD, hub extension, BSF	10	
57	1B7376	€8.28 NUT, BSF	10	
		031-396 NA HUB, wire wheel only	2	BN1 from C.E.222571,
		031-293 €6.84 STUD, hub extension, UNF	10	BN2, BN4, BN6
		ATB7198 €6.72 NUT, UNF	10	
		031-291 NA HUB, wire wheel	2	
		031-293 €6.84 STUD, hub extension, UNF	10	BN7-BJ8
		ATB7198 €6.72 NUT, UNF	10	
58	GHB131	€67.80 BEARING, wheel	2	
59	GHS200	€4.08 SEAL, oil (2-7/8")	2	
60	ATC7588	€1.44 O-RING	2	BN4-BJ8
61	675-130	€24.48 SPACER, bearing	2	BN1 from C.E.221536, BN2, BN4, BN6
		675-450 €25.20 SPACER, bearing	2	BN7-BJ8
62	ATC7062	€23.40 NUT, RH thread	2	BN1 from C.E.221536, to C.E.228011
63	324-635	NA LOCKWASHER	2	
		ATC7309 €23.40 NUT, LH thread (on LH side)	1	BN1 from C.E.228012,
		ATC7062 €23.40 NUT, RH thread (on RH side)	1	BN2-BJ8
		031-292 €5.04 LOCKWASHER	2	
65	ATC7237	€77.88 HUB EXTENSION, LH	1	BN1 from C.E.221536,
		ATC7236 €77.88 HUB EXTENSION, RH	1	BN2-BJ8 to (c)26704
		BTC407 €77.88 HUB EXTENSION, LH	1	BJ8 from (c)26705
		BTC406 €77.88 HUB EXTENSION, RH	1	

Knock-Offs

66	AHH7318	€40.80 WHEEL SPINNER, 2 eared, 12 tpi, LH	2	
	AHH7317	€40.80 WHEEL SPINNER, 2 eared, 12 tpi, RH	2	
67	AHH7316	€40.08 WHEEL SPINNER, octagonal, 12 tpi, LH	2	BN1, BN2, BN4, BN6, BN7,
	AHH7315	€35.16 WHEEL SPINNER, octagonal, 12 tpi, RH	2	BT7, BJ7, BJ8 to (c)26704
68	AHH73183	€75.36 WHEEL SPINNER, 3 eared, 12 tpi, LH	2	
	AHH73173	€75.36 WHEEL SPINNER, 3 eared, 12 tpi, RH	2	
	AHA7374	€46.92 WHEEL SPINNER, 2 eared, 8 tpi, LH	2	
	AHA7373	€46.92 WHEEL SPINNER, 2 eared, 8 tpi, RH	2	
	88G607	€37.80 WHEEL SPINNER, octagonal, 8 tpi, LH	2	BJ8 from (c)26705
	88G606	€37.80 WHEEL SPINNER, octagonal, 8 tpi, RH	2	
	107949/3	€80.40 WHEEL SPINNER, 3 eared, 8 tpi, LH	2	
	107948/3	€80.40 WHEEL SPINNER, 3 eared, 8 tpi, RH	2	

*Borrani style

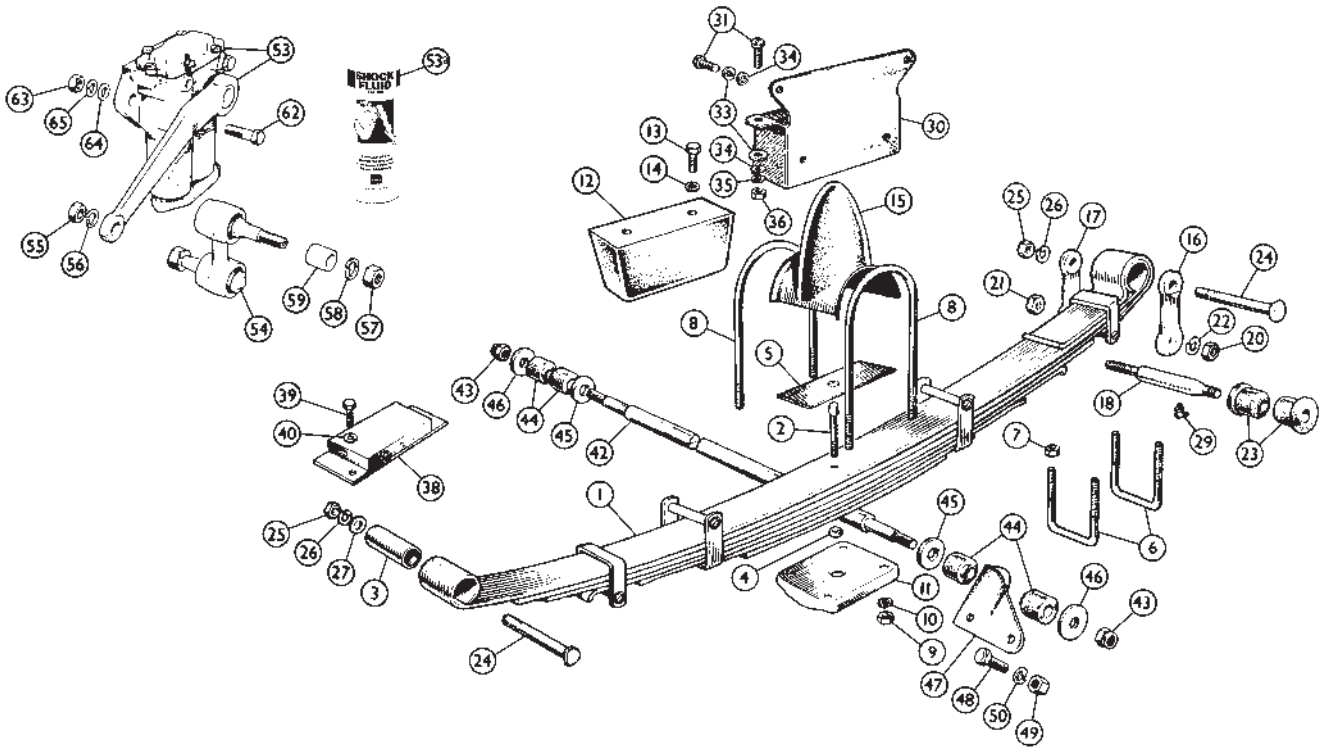

ill. Part Number Price €ea. Description

Rear Suspension BN1 to early BJ8

Spiral Bevel Axle: BN1 to C.E.221535.
Hypoid Axle: BN1 from C.E.221536, BN2, BN4, BN6, BN7, BT7, BJ7; BJ8 to (c)26704

Req.	Part Number	Price €ea.	Description	Details
1	1B8929	€129.36	LEAF SPRING ASSEMBLY	2 BN1, BN2
	11B5266X	€152.16	LEAF SPRING ASSEMBLY	2 BN4, BN6, BN7, BT7, BJ7, BJ8 to (c)26704
2	725-160	NA	TOE BOLT	2
3	88G278	€9.72	BUSH, front & rear	4
	680-961	€42.24	BUSH SET, rear, polyurethane	1
4	GHF200	€0.96	NUT	2
5	675-455	€4.08	PACKING PIECE, fibre	2 hypoid axle
	675-445	€18.72	PACKING PIECE, tapered	2
6	031-397	NA	'U' BOLT (use late u-bolt & nuts)	4 spiral bevel axle
7	AJD8336Z	€1.80	NUT, BSF	8
8	AHC109	€4.44	'U' BOLT	4
9	GHF223	€1.56	NUT, UNF, nyloc	8 hypoid axle
10	GHF333	€0.72	WASHER, locking	8
11	725-165	€44.16	PLATE, 'U' bolt	2
12	675-480	€33.12	BUFFER, on body	2
13		NA	BOLT	2 spiral bevel axle
14	GHF332	€0.84	WASHER, locking	2
15	11B5068	€22.08	BUFFER, on axle	2
16	675-465	€18.48	SHACKLE, outer	2 hypoid axle
17	675-475	€18.96	SHACKLE, inner	2
18		NA	SHACKLE PIN, bottom, BSF	2
20	AJD8106Z	€0.96	NUT, pin, BSF	2 BN1 as fitted
21		NA	LOCKNUT, BSF	4
	1G9320	€14.16	SHACKLE PIN, bottom, UNF	2
	GHF202	€0.72	NUT, pin, UNF	2 All other models
	NT606041	€1.08	LOCKNUT, UNF	4
22	GHF333	€0.72	WASHER, locking	4
23	1G9800	€5.28	IRON BUSH, bracket on chassis	4
24	1G9321	€5.64	PIN, rear spring, top & front, UNF	4
		NA	NUT, BSF	4 BN1 as fitted
		€0.72	NUT, UNF	4 All other models
25	GHF203	€0.72	NUT, UNF	4
26	GHF334	€1.32	WASHER, locking	4
27	GHF303	€0.72	WASHER, plain	4
29		NA	NIPPLE, grease	2 BN1, BN2
	7H3858	€3.96	NIPPLE, grease	2 BN4, BN6, BN7, BT7, BJ7, BJ8 to (c)26704
30	806-190	€55.68	BUMP STOP BOX	2 spiral bevel axle
	SC40	€25.44	BUMP STOP BOX	2 hypoid axle
31	GHF117	€0.72	BOLT, box to body and wheelarch	8
33	WM57	€1.20	WASHER, plain, large	4
34	GHF300	€1.08	WASHER, plain, small	8
35	GHF331	€0.84	WASHER, locking	8
36	GHF200	€0.96	NUT	8/4 qty increases on BN1, BN2
38	675-500	NA	BUFFER, rebound, rear axle	2 BN1, BN2

ill. Part Number Price €ea. Description

Req.	Part Number	Price €ea.	Description	Details
	675-510	€8.40	BUFFER, rebound, rear axle	2 BN4, BN6, BN7, BT7, BJ7, BJ8 to (c)26704
	39	SH604051	€0.72 BOLT, buffer to frame	4
	40	GHF331	€0.84 WASHER, locking	4
	42	851-300	€67.68 PANHARD ROD	1
	43	GHF223	€1.56 LOCKNUT	2
	44	3H3079	€1.68 BUSH, rubber	4
		3H3079SPK	€22.56 BUSH SET, rubber	1
	45	140416	€0.96 WASHER, inner	2
	46	PWZ206	€1.20 WASHER, outer	2
		675-440	€16.68 BRACKET, panhard rod	1 spiral bevel axle
	47	675-440	€16.68 BRACKET, panhard rod	1
	48	SH606071	€0.84 BOLT, fixing bracket	2 hypoid axle
	49	GHF202	€0.72 NUT	2
	50	GHF333	€0.72 WASHER, locking	2
	53	1B7448	€177.48 SHOCK ABSORBER, rear, LH	1
		1B7445	€177.48 SHOCK ABSORBER, rear, RH	1
	53a	GGL832110	€11.76 DYNOLITE SHOCK ABSORBER OIL, 1lt	1
		3H3088	€40.32 SHOCK LINK ASSEMBLY	2
		AJD8106Z	€0.96 NUT, link to arm, BSF	2 spiral bevel axle
		NA	NUT, link to axle, BSF	2
		GHF303	€0.72 WASHER, plain	2
	54	1B7463	€42.36 SHOCK LINK ASSEMBLY	2
	55	GHF202	€0.72 NUT, link to arm, UNF	2
	56	GHF333	€0.72 WASHER, locking	2 hypoid axle
	57	GHF203	€0.72 NUT, link to axle, UNF	2
	58	GHF334	€1.32 WASHER, locking	2
	59	725-130	NA DISTANCE TUBE, link to axle bracket	2
		NA	BOLT, shock to frame, BSF	4 BN1 as fitted
		NA	NUT, BSF	4
	62	53K1048	€1.20 BOLT, shock to frame, UNF	4 All other models
	63	FNZ506	€1.32 NUT, UNF	4
	64	WP9	€2.04 WASHER, plain	4
	65	GHF333	€0.72 WASHER, locking	4

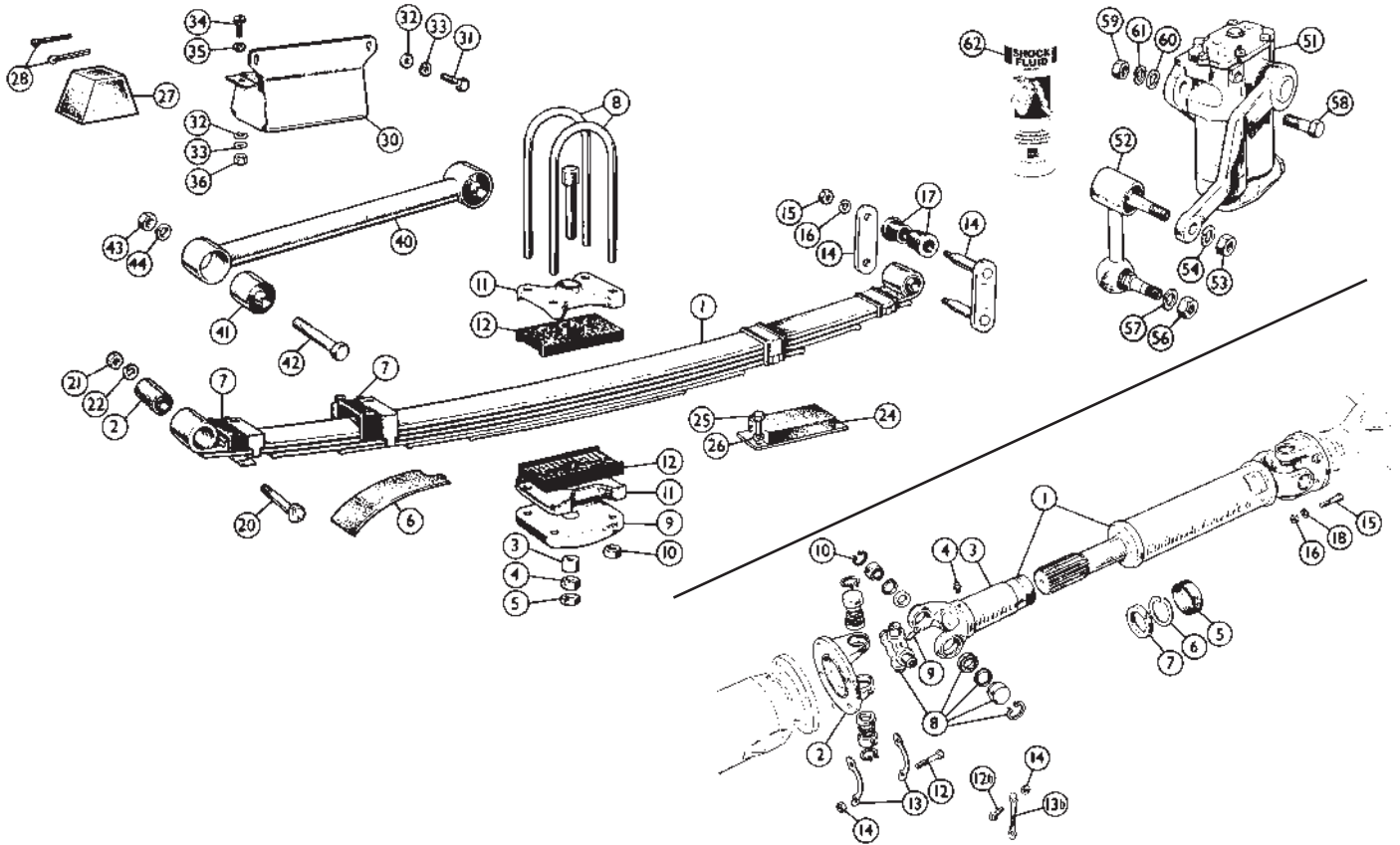

iii. Part Number Price €ea. Description Req. Details

Rear Suspension, BJ8 from (c)26705

Part Number	Price €ea.	Description	Req.	Details	
1	AHB9980X	€128.52	LEAF SPRING ASSEMBLY	2	
2	88G278	€9.72	BUSH	2	
	680-961	€42.24	BUSH SET, rear, polyurethane	1	
3	ACA5000	€3.72	SPACER	2	
4	GHF201	€0.84	NUT	2	
5	NT605041	€0.84	LOCKNUT	2	
6	AHH7078M	€12.00	STRIP, interleaf, per meter	6	original springs only
7	AHB6707	€3.48	PAD, clip, rubber	8	
8	266-585	NA	U' BOLT, spring (original type)	4	
	AHC109	€4.44	U' BOLT, spring (replacement)	4	
9	031-399	NA	PLATE, 'U' bolt	2	
10	GHF223	€1.56	NUT	8	
11	031-400	€19.68	PLATE, locating	4	
12	ACG5002	€1.80	PAD, seating	4	
14	AHB9977K	€28.08	SHACKLE ASSEMBLY	2	
15	GHF202	€0.72	NUT, pin	4	
16	GHF333	€0.72	WASHER, locking	4	
17	282-858	€7.68	BUSH SET, shackle pins (8 bushes)	1	
	2A5176SPK	€45.72	BUSH SET, shackle pins, Polyurethane	1	SuperPro
20	1G9321	€5.64	PIN, spring, front	2	
21	GHF203	€0.72	NUT	2	
22	GHF334	€1.32	WASHER, locking	2	
24	675-510	€8.40	BUFFER, rebound, rear axle	2	
25	SH604051	€0.72	BOLT, buffer to frame	4	
26	GHF331	€0.84	WASHER, locking	4	
27	2A7142	€6.60	BUMP STOP, rear axle	2	
28	GHF513	€2.16	SPLIT PIN	4	
30	806-200	€28.80	BUMP STOP BOX	2	
31	SH604041	€0.84	BOLT, box to body	4	
32	GHF300	€1.08	WASHER, plain	8	
33	GHF331	€0.84	WASHER, locking	8	
34	SE604041	€0.84	SCREW, box to body	4	
35	WM57	€1.20	WASHER, plain	2	
36	GHF200	€0.96	NUT	4	
40	675-515	€108.24	RADIUS ARM ASSEMBLY	2	
41	675-520	€13.44	BUSH	4	
42	322-155	€2.40	BOLT	4	
43	GHF203	€0.72	NUT	4	
44	GHF334	€1.32	WASHER, locking	4	
	GSA154	€182.40	SHOCK ABSORBER, rear, LH	1	
	GSA153	€182.40	SHOCK ABSORBER, rear, RH	1	
52	17H9276	€28.08	LINK ASSEMBLY	2	
53	FNZ507	€1.68	NUT, link to arm	2	
54	GHF334	€1.32	WASHER, locking	2	
56	FNZ508	€2.40	NUT, link	2	
57	GHF335	€0.96	WASHER, locking	2	
58	725-150	€2.64	BOLT, shock to frame	4	
59	GHF203	€0.72	NUT	4	
60	GHF303	€0.72	WASHER, plain	4	
61	GHF334	€1.32	WASHER, locking	4	
62	GGL832110	€11.76	DYNOLITE SHOCK ABSORBER OIL, 1lt	1	

iii. Part Number Price €ea. Description Req. Details

Driveshaft (All Models)

Part Number	Price €ea.	Description	Req.	Details
1	NA	DRIVESHAFT, 21-1/8"	1	BN1 to C.E.140204
	NA	DRIVESHAFT, 20-3/4"	1	BN1 C.E.140205 to 221535
	NA	DRIVESHAFT, 20"	1	BN1 from C.E.221536, BN2
	NA	DRIVESHAFT, 30"	1	BN4, BN6, BN7, BT7, BJ7, BJ8
2	268-070	NA	YOKE, flange	2
3	031-297	NA	YOKE, sleeve	1
4	031-298	€54.60	YOKE, sleeve	1
5	UHN400	€1.56	NIPPLE, grease	1
6	675-080	NA	CAP, dust, sleeve yoke	1
7	675-090	NA	WASHER, dust cap, steel	1
8	675-095	€3.00	WASHER, dust cap, cork	1
	GUJ116	€16.56	U-JOINT, with grease nipple	2
	GUJ116Z	€21.00	U-JOINT, with grease nipple	2
	GUJ102	€21.72	U-JOINT, permanently lubricated	2
9	7H3858	€3.96	NIPPLE, grease	2
10	NA	CIRCLIP, bearing	8	
12	NA	BOLT (use later UNF bolts & nuts)	A/R	BN1 as fitted
	53K1048	€1.20	BOLT, flange to gearbox, UNF (hex head)	4
12b	662-095	€7.68	BOLT, flange to overdrive, UNF	4
13	675-110	NA	LOCKTAB, flange to gearbox (curved)	4
13b	2K5914	€2.76	LOCKTAB, flange to overdrive (straight)	2
14	AJD8106Z	€0.96	NUT, BSF	4
	GHF202	€0.72	NUT, UNF	4
15	53K1048	€1.20	BOLT, flange to differential, UNF	4
16	AJD8106Z	€0.96	NUT, BSF	4
	GHF223	€1.56	NUT, UNF	4
18	GHF333	€0.72	WASHER, locking	4

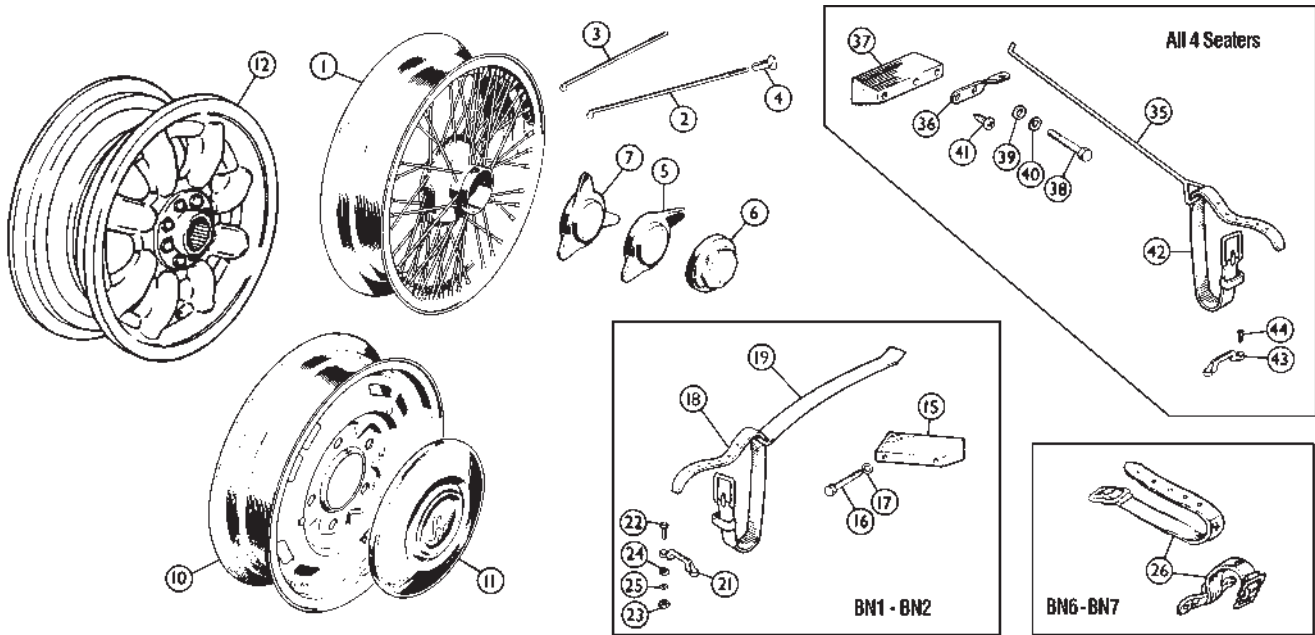

ill.	Part Number	Price €ea.	Description	Req.	Details
Road Wheels & Fittings					
60-spoke wheels will fit BN1 with early spiral bevel rear axles, and all disc-braked 3000s. 72-spoke wheels will fit as indicated. Wheels marked * are designed to use tubeless tyres.					
1	WWP450	€256.80	WIRE WHEEL, painted, 48 spoke	5	BN1, BN2, BN4, BN6, BN7, BT7, BJ7 to (c)24366 15" x 4"
	WWC450	€358.80	WIRE WHEEL, chrome, 48 spoke	5	
	WWP452	€250.80	WIRE WHEEL, painted, 60 spoke	5	BJ7 from 24367, BJ8 15" x 4-1/2"
	WWC452	€350.40	WIRE WHEEL, chrome, 60 spoke	5	
	WWP459	€330.00	WIRE WHEEL, painted, 72 spoke	5	optional, 15" x 5
	WWC459	€428.40	WIRE WHEEL, chrome, 72 spoke	5	
	WWP457C	€315.60	WIRE WHEEL, painted, 72 spoke	5	optional, 15" x 5-1/2" (cars with ft. disc brakes)
	WWC457C	€421.20	WIRE WHEEL, chrome, 72 spoke	5	
2	7H1805	€6.48	SPOKE, painted, long (outer)	16*	48 spoke
	7H1805CP	€10.80	SPOKE, chrome, long (outer)	16*	
3	7H1806	€6.48	SPOKE, painted, short (inner)	32*	60 spoke
	7H1806CP	€10.80	SPOKE, chrome, short (inner)	32*	
2	17H8619	€6.48	SPOKE, painted, long (outer)	20*	72 spoke 15 x 5"
	17H8619CP	€10.80	SPOKE, chrome, long (outer)	20*	
3	17H8620	€6.48	SPOKE, painted, short (inner)	40*	72 spoke 15 x 5-1/2"
	17H8620CP	€10.80	SPOKE, chrome, short (inner)	40*	
2	200-170	NA	SPOKE, painted, long (outer)	24*	48*
	200-180	NA	SPOKE, chrome, long (outer)	24*	
3	200-165	€6.48	SPOKE, painted, short (inner)	48*	48*
	200-175	€10.80	SPOKE, chrome, short (inner)	48*	
2	27H8503	€6.48	SPOKE, painted, long (outer)	24*	72 spoke 15 x 5-1/2"
	37H3650	NA	SPOKE, chrome, long (outer)	24*	
3	27H8502	€6.48	SPOKE, painted, short (inner)	48*	48*
	37H3649	€10.80	SPOKE, chrome, short (inner)	48*	
*Quantities are per wheel.					
4	7H1709	€1.20	NIPPLE, plain	A/R	BN1, BN2, BN4, BN6, BN7, BT7, BJ7, BJ8 to (c)26704
	37H3651	€2.04	NIPPLE, chrome	A/R	
5	AHH7318	€40.80	WHEEL SPINNER, 2 eared, 12 tpi, LH	2	BJ8 from (c)26705
	AHH7317	€40.80	WHEEL SPINNER, 2 eared, 12 tpi, RH	2	
6	AHH7316	€40.08	WHEEL SPINNER, octagonal, 12 tpi, LH	2	BJ8 from (c)26705
	AHH7315	€35.16	WHEEL SPINNER, octagonal, 12 tpi, RH	2	
7	AHH73183	€75.36	WHEEL SPINNER, 3 eared, 12 tpi, LH	2	BJ8 from (c)26705
	AHH73173	€75.36	WHEEL SPINNER, 3 eared, 12 tpi, RH	2	
5	AHA7374	€46.92	WHEEL SPINNER, 2 eared, 8 tpi, LH	2	BJ8 from (c)26705
	AHA7373	€46.92	WHEEL SPINNER, 2 eared, 8 tpi, RH	2	
6	88G607	€37.80	WHEEL SPINNER, octagonal, 8 tpi, LH	2	BJ8 from (c)26705
	88G606	€37.80	WHEEL SPINNER, octagonal, 8 tpi, RH	2	
7	107949/3	€80.40	WHEEL SPINNER 3 eared, 8 tpi, LH	2	BJ8 from (c)26705
	107948/3	€80.40	WHEEL SPINNER, 3 eared, 8 tpi, RH	2	
**Borrani style					
10	854-280	NA	WHEEL, disc	5	BN4 thru BJ8
11	031-312	€69.84	HUB CAP, disc wheel	4	
12	GAC8255X	€318.00	WHEEL, Minator, centre lock, silver	5	15 x 5-1/2"

ill.	Part Number	Price €ea.	Description	Req.	Details
15	221-680	NA	BLOCK, spare wheel	1	BN1, BN2
16	NA	NA	BOLT, block to rear wheel arch	2	
17	NA	NA	WASHER, plain	2	BN1, BN2
18	221-645	€117.12	STRAP ASSEMBLY, spare wheel	1	
19	221-655	€32.16	BAR, spare wheel	1	
21	2K9579	€7.56	STAPLE, chrome, strap retaining	1	BN1, BN2
22	NA	NA	SCREW, staple to axle cover panel	2	
23	GHF206	€1.32	NUT	2	BN1, BN2
24	NA	NA	WASHER, plain	2	
25	GHF331	€0.84	WASHER, locking	2	BN1, BN2
26	221-675	€83.40	STRAP ASSEMBLY, spare wheel	1	
	GHF206	€1.32	NUT	2	BN6, BN7
	NA	NA	WASHER, plain	4	
	RMP310	€1.44	SCREW	4	BN6, BN7
	GHF331	€0.84	WASHER, locking	4	
35	221-650	€35.40	ROD, retaining spare wheel	1	BN4, BT7, BJ7, BJ8
36	221-665	€13.20	BRACKET, rod	1	
37	221-640	€20.04	BLOCK, spare wheel	2	BN4, BT7, BJ7, BJ8
38	BH604221	€1.44	BOLT, block to body	4	
39	GHF300	€1.08	WASHER, plain	4	BN4, BT7, BJ7, BJ8
40	GHF331	€0.84	WASHER, locking	4	
41	NA	NA	SCREW, wood	1	BN4, BT7, BJ7, BJ8
42	14B6771	€42.48	STRAP, securing spare wheel	1	
43	2K9579	€7.56	STAPLE, chrome, strap retaining	1	BN4, BT7, BJ7, BJ8
44	RMP310	€1.44	SCREW, chrome	2	

Wheel Notes

100-4 BN1

All BN1s came from the factory with painted 48 spoke Dunlop wire wheels, 15" X 4". 60 spoke 15" X 4.5" wire wheels or 72 spoke 15" X 5" wire wheels will fit so long as the car has the original 1 7/8" wide brake drums. If the front brakes have been converted to the later 2 1/4" wide brake drums, the 60 spoke wheels will not fit. If 60 or 72 spoke wheels are used, the tyres must be carefully selected for fit, especially if the car still has the original BN1 wings (with smaller wheel openings than the BN2 wings). Many BN1's left the factory with BN2 wings.

100-4 BN2, 100-6 BN4 & BN6

All BN2, BN4 and BN6 originally had 4J x 15" steel wheels. Factory optional painted 48 spoke 15" X 4" Dunlop wire wheels. 72 spoke 15" X 5" wire wheels will also fit. 60 spoke wheels will not fit the front due to the 2-1/4" wide brake drums interfering with the spokes.

3000 BN7, BT7, and BJ7 to 24366

Standard for all 3000's were 4J x 15" steel wheels, but most were fitted with the "optional" painted 48 spoke 15" X 4" Dunlop wheels. We suggest fitting the stronger 60 or 72 spoke wheels.

3000 BJ7 from 24367, BJ8

4J x 15" steel wheels were "standard", but most were fitted with the "optional" painted 60 spoke Dunlop wire wheels 15" X 4.5". The stronger 72 spoke wheels will also fit.

Original Equipment	100-4		100-6		3000 MK1		3000 MK2		3000 MK3		
	BN1	BN2	BN4	BN6	BN7	BT7	BN7	BT7	BJ7 to C24366	BJ7 from C24367	BJ8
Disc Wheels	Not offered		4J x 15, standard								
Dunlop 48 spoke, painted	15 x 4, standard		15 x 4, optional to BJ7 C24366						not offered		
Dunlop 60 spoke, painted	not offered									15 x 4.5, optional	
What Fits											
48 Spoke 454-610 Painted 15 x 4 454-615 Chrome 15 x 4	Will fit all cars, but loads generated by modern tyres make 60 or 72 spoke wheels a better choice if they will fit your car.										
60 Spoke 454-620 Painted 15 x 4.5 454-630 Chrome 15 x 4.5	Fits BN1	Will not fit on front because the brake drums are 2-1/4" wide.			Fits all 3000						
72 Spoke 454-665 Painted 15 x 5 454-660 Chrome 15 x 5	Will fit all cars, but the tyres must be carefully selected for BN1-2 to avoid rubbing, especially with BN1 wings.										

Tools

Ill	Part Number	Price €ea.	Description	Req.	Details
1	C27290	€49.32	WHEEL HAMMER, copper/hide, 2 lb.	1	
	386-000	€30.60	WHEEL HAMMER, copper, 1 lb.	1	
	88G329	NA	WHEEL HAMMER, zinc alloy, 2 lb.	1	
2	AHH5839	€10.20	SPANNER, octagonal knock-offs	1	
4	MM385-800	€17.52	SPOKE ADJUSTING SPANNER	1	
8	31G5961	NA	WHEEL BRACE (period style repl.)	1	disc wheels
9	11H1051	€8.64	LEVER, hub cap removal	1	
10	386-840	NA	TYRE VALVE TOOL	1	
12	AJJ281K	NA	TYRE IRON SET	1	similar to originals
15	AHH5124K	€210.12	JACK with handle ("King Dick" style)	1	BN1, BN2
	NA	NA	JACK	1	BN4, BN6, BN7, BT7 to (c)2263
	NA	NA	JACK	1	BN7 (c)2264 to (c)10610, BT7 (c)2264 to (c)10564
	NA	NA	HANDLE, for jack	1	BN4, BN6, BN7 to (c)10610, BT7 to (c)10564
16	NA	NA	JACK	1	BN7 from (c)10611, BT7 from (c)10565, BJ7, BJ8
17	NA	NA	TOMMY BAR, jack	1	
18	500905	NA	POINT GAP ADJUSTING TOOL	1	
20	221-220	€122.64	TOOL ROLL	1	BN1 - BN2
	221-240	€39.12	TOOL ROLL	1	BN4 thru early BN7 / BT7
	221-250	NA	TOOL ROLL	1	late BN7 / BT7 thru BJ8
	221-252	€46.68	TOOL ROLL (replacement)	1	BN4 - BJ8
21	221-210	NA	JACK BAG	1	BN1, BN2
	221-230	€47.04	JACK BAG	1	BN4 thru BJ8
	221-225	€36.60	JACK HANDLE BAG, short	1	100-4 Shelley jacks
	221-235	€39.96	JACK HANDLE BAG, long	1	100-4 King Dick jack
23	221-205	€18.72	STRAP, jack retaining	1	from BN7 (c)11280, from BT7 (c)11585

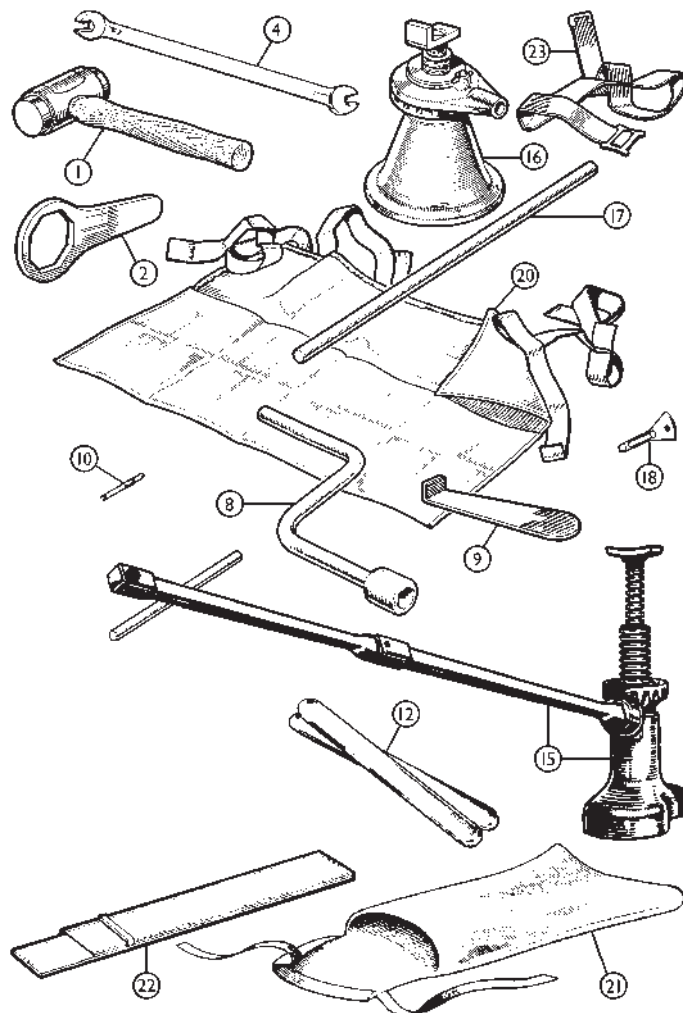

Right hand drive illustrated

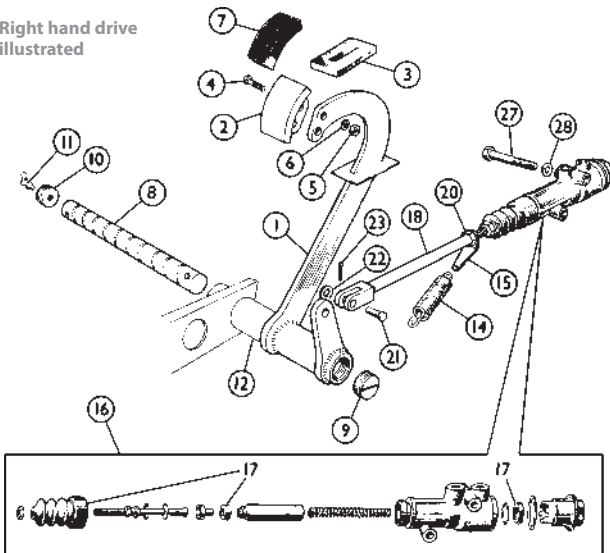

Reservoir is listed on page 86.

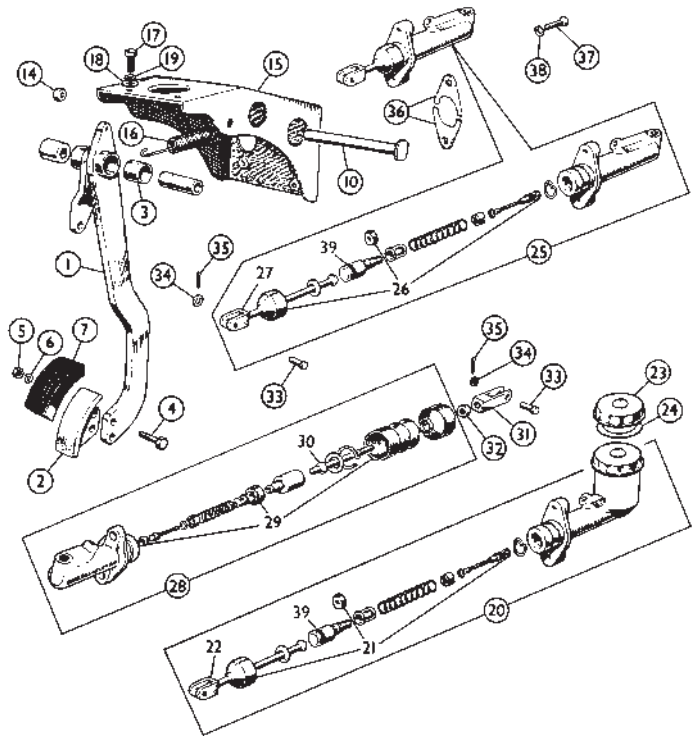

ill. Part Number Price €ea. Description Req. Details

Brake Pedals & Master Cylinders BN1, BN2

Part Number	Price €ea.	Description	Req.	Details
1 682-115	€416.40	PEDAL, brake	1	LHD
	NA	PEDAL, brake	1	RHD
2	NA	PAD, pedal (metal)	1	
3 682-120	€14.64	DRAFT EXCLUDER, pedal	1	
4	NA	BOLT, pad to pedal	2	
5 GHF200	€0.96	NUT, bolt	2	
6 GHF331	€0.84	WASHER, locking	2	
7 1B8751	€2.76	PEDAL PAD, rubber	1	
8 021-701	€106.08	SHAFT, brake and clutch pedal	1	LHD
9 021-723	€101.52	SHAFT, brake and clutch pedal	1	RHD
10 725-055	NA	PLUG	1	
11 725-060	NA	PLUG, for grease nipple	1	
12 LN30041	€2.16	NIPPLE, grease	1	
13	NA	SLEEVE, spacing	1	RHD
14 021-482	NA	SPRING, brake pedal return	1	LHD
15 021-483	NA	EYE, for spring	1	LHD
	NA	SPRING, brake pedal return	1	RHD
	NA	EYE, for spring	1	RHD
16 1B8927	€262.80	MASTER CYLINDER ASSEMBLY	1	reservoir shown on p86
17 8G8106	€26.52	REPAIR KIT, master cylinder, TRW brand	1	
18 8G8106Z	NA	REPAIR KIT, master cylinder, aftermarket	1	
19 021-479	€93.12	FORK & EXTENSION, pushrod	1	LHD
	NA	FORK, pushrod	1	RHD
20 AJD8105Z	€0.72	NUT	1	
21 CLZ515	€2.40	CLEVIS PIN	1	
22 GHF301	€0.60	WASHER, plain	1	
23	NA	SPLIT PIN	1	
	NA	PACKING PIECE, master cylinder	1	RHD
	NA	BOLT, packing piece to bracket	1	
	NA	BOLT, master cylinder to frame	2	LHD
	NA	BOLT, master cylinder to frame	2	RHD
27	NA	BOLT, master cylinder to frame	2	RHD
28 GHF332	€0.84	WASHER, locking	2	

Note for 513-321 late BN4-BN6 Master Cylinder:

This is a replacement cylinder with black steel adapters in the inlet and outlet ports. Remove these adapters and washers as they are not needed. An incorrect pushrod may or may not be included, which should be replaced with your old original one or a new 513-322.

ill. Part Number Price €ea. Description Req. Details

Brake Pedals & Master Cylinders BN4 to BJ8

Part Number	Price €ea.	Description	Req.	Details
1	NA	PEDAL, brake	1	BN4, BN6, BN7 to
2	NA	PAD, pedal (metal)	1	(c)16038, BT7 to (c)15880
	NA	PEDAL, brake	1	BN7 from (c)16039,
	NA	PAD, pedal (metal)	1	BT7 from (c)15881, BJ7, BJ8
3 1G9310	NA	BUSH	2	
4	NA	BOLT, pad to pedal	2	
5 GHF200	€0.96	NUT	2	
6 GHF331	€0.84	WASHER, locking	2	
7 1B8751	€2.76	PEDAL PAD, rubber	1	
10 021-486	NA	SHAFT, brake and clutch pedal	1	
14 GHF222	€1.08	NUT, shaft	1	
15 021-487	NA	BRACKET, brake and clutch pedal lever	1	
16 329-075	€9.96	SPRING, brake pedal return	1	
17 SH605051	€1.80	BOLT, pedal bracket to pedal box	2	
18 PWZ205	€0.72	WASHER, plain	2	
19 GHF332	€0.84	WASHER, locking	2	
20 130887	€54.60	MASTER CYLINDER, 3/4" bore	1	
		(Replacement with plastic cap. Orig. caps do not fit.)		
21 GRK1027	€11.52	REPAIR KIT, TRW	1	
22	NA	PUSH ROD	1	BN4 to C.E.48862
23 500201	€10.80	CAP, bright finish as orig.	1	
24 500201Z	€7.68	CAP, black painted	1	
25 106095	€1.44	SEAL, filler cap	1	
26 582-505	€9.00	SEAL, splash-proof (replacement)	1	
27 513-321	€98.76	MASTER CYLINDER, 3/4" bore	1	BN4 from C.E.48863,
28 GRK1027	€11.52	REPAIR KIT, TRW	1	BN6 See note at bottom
29 513-322	€16.80	PUSH ROD	1	of left hand column
30 11B5510	€77.88	MASTER CYLINDER, 5/8" bore	1	BN7, BT7, BJ7
31 GRK1029	€12.72	REPAIR KIT, master cylinder	1	without servo
32 513-322	€16.80	PUSH ROD	1	
33 27H4717	€95.88	MASTER CYLINDER, 7/8" bore, TRW/Lucas	1	
34 27H4717Z	€58.80	MASTER CYLINDER, 7/8" bore, aftermarket	1	BN7, BT7, BJ7, BJ8
35 18G8011	€13.80	REPAIR KIT, master cylinder	1	with servo
36	NA	PUSH ROD	1	
37	NA	FORK, pushrod	1	
38 NT605041	€0.84	LOCKNUT, fork to pushrod	1	
39 CLZ513	€1.32	CLEVIS PIN	1	BN4, BN6, BN7, BT7, BJ7
	€2.40	CLEVIS PIN	1	BJ8
40 GHF301	€0.60	WASHER, plain	1	
41 GHF502	€1.08	SPLIT PIN	1	
42 021-488	€3.24	PACKING PIECE, master cylinder	2	
43 GHF103	€1.20	BOLT, master cylinder to pedal bracket	2	
44 GHF332	€0.84	WASHER, locking	2	
45	NA	DUST SEAL on some old pistons - discontinued, not req'd.		

Note: Remote reservoirs are listed on page 86.

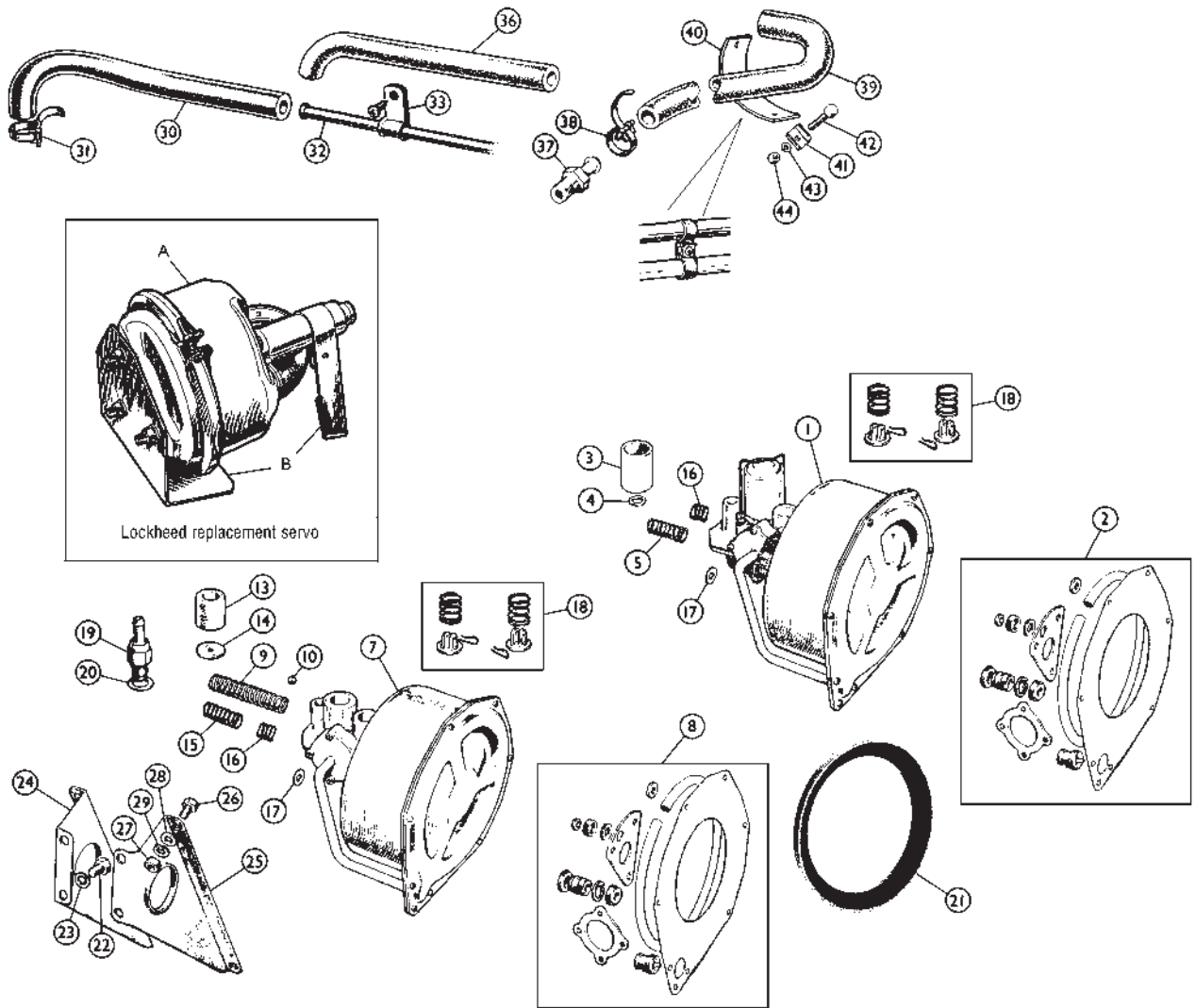

Part Number	Price €ea.	Description	Req.	Details
Brake Servo				
Note: Original Girling servos have not been available for many years.				
A LKLE10117	€380.40	SERVO ASSEMBLY, Lockheed replacement	1	
Although this kit includes brackets, they are not well suited for use on Healeys. We strongly suggest using our 021-489 Bracket Kit.				
BHA4700XSK	€135.36	REPAIR KIT, Lockheed servo	1	
LKLE10117Z	€156.36	SERVO ASSEMBLY	1	aftermarket replacement
B 021-489	€49.20	BRACKET SET	1	replacement servos - req'd. to mount servo
1	NA	SERVO ASSEMBLY	1	
2 18G8126Z	€75.36	REPAIR KIT, servo	1	Original type (Girling) BN7, BT7, BJ7, BJ8 to (c)25399
3 587-250	NA	ELEMENT, air filter	1	
4	NA	SEAL, air filter to body	1	
5	NA	SPRING, piston return	1	
	NA	PISTON, hydraulic	1	
7	NA	SERVO ASSEMBLY	1	
8 18G8126Z	€75.36	REPAIR KIT, servo	1	
9	NA	SPRING, piston return	1	
10 BLS105	€1.08	BALL, piston	1	Original type (Girling) BJ8 from (c)25400
	NA	PISTON, hydraulic	1	
13	NA	ELEMENT, air filter	1	
14	NA	SEAL, air filter to body	1	
15	NA	SPRING, piston return	1	
16	NA	SPRING, piston return	1	
17	NA	WASHER, cylinder to body bolt, copper	3	
18 37H8775	NA	REPAIR KIT, air valve	1	
19 582-990	€32.76	KIT, non-return valve	1	
20	NA	GASKET, valve to servo unit	1	
21 021-205	€60.00	SEAL, leather, vacuum piston	1	original Girling servos
22 SH606061	€1.44	BOLT, servo unit to mounting bracket	3	
23 GHF333	€0.72	WASHER, locking	3	
24 587-305	€42.36	BRACKET, servo unit mounting, RH	1	
25 587-315	€42.36	BRACKET, servo unit mounting, LH	1	
26 GHF120	€0.72	BOLT, bracket to pedal box	4	
27 GHF201	€0.84	NUT, bolt	4	
28 PWZ205	€0.72	WASHER, plain	4	
29 GHF332	€0.84	WASHER, locking	4	

Part Number	Price €ea.	Description	Req.	Details
30 CRC2131A	€12.00	HOSE, valve to vacuum pipe	1	
31 GHC11016	€4.44	CLIP, hose, original strap type	2	
MM326-250	€3.12	CLIP, hose, replacement	2	
32 021-706	NA	PIPE, vacuum	1	BN7, BT7, BJ7
33 PCR607	€2.52	CLIP, pipe to pedal box top	1	
PCR607	€2.52	CLIP, pipe to dash panel	1	
36 CRC2131A	€12.00	HOSE, vacuum pipe to union	1	BJ7
37 21K8342	NA	UNION, hose to manifold	1	
38 GHC11016	€4.44	CLIP, hose, original strap type	2	BJ7, BJ8
MM326-250	€3.12	CLIP, hose, replacement	2	
39 CRC2131A	€12.00	HOSE, non-return valve to manifold union	1	
40 AHH6866K	€6.60	STRAP ASSY, hose	1	
41 AHH6866	€2.64	PLATE, strap	2	BJ8
42 PMZ314	€0.72	SCREW	1	
43 GHF331	€0.84	WASHER, locking	1	
44 GHF206	€1.32	NUT	1	

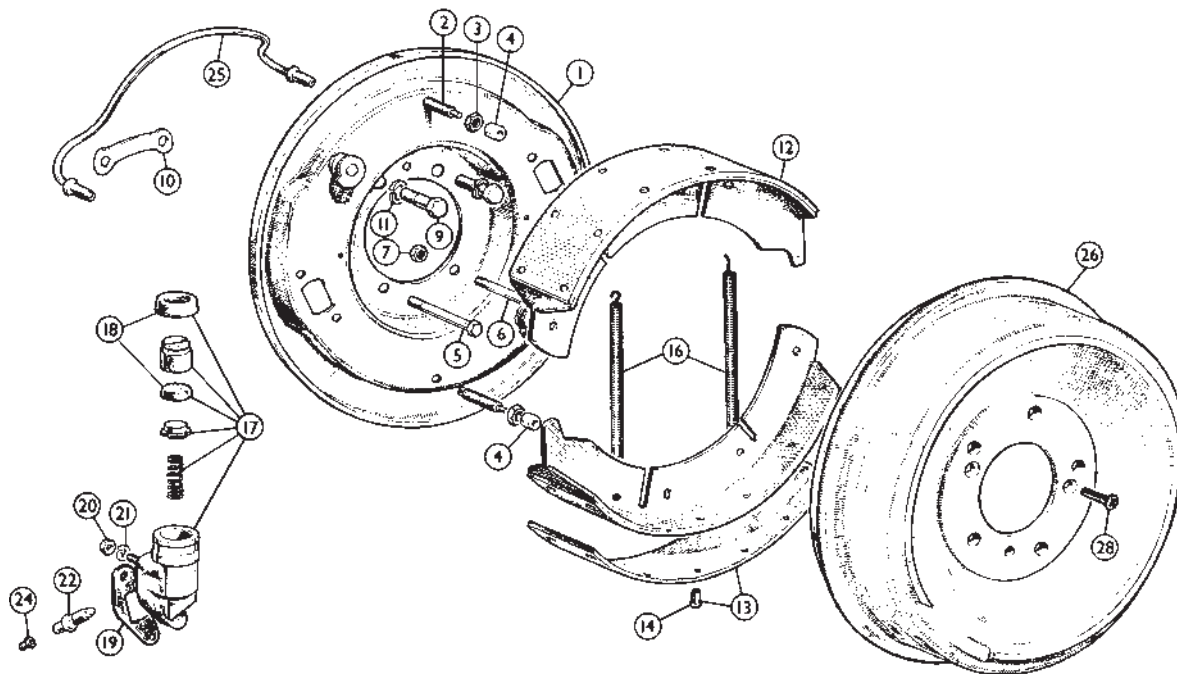

ill.	Part Number	Price €ea.	Description	Req.	Details
Front Drum Brakes					
1	NA		BACKPLATE, RH	1	BN1
	NA		BACKPLATE, LH	1	
	NA		BACKPLATE, RH	1	BN2
	NA		BACKPLATE, LH	1	
	NA		BACKPLATE, RH	1	BN4, BN6 wire wheels
	NA		BACKPLATE, LH	1	
	NA		BACKPLATE, RH	1	BN4, BN6 disc wheels
	NA		BACKPLATE, LH	1	
2	NA		POST, steady	4	BN1
3	AJD8105Z	€0.72	NUT, steady post	4	
2	586-015	€6.12	POST, steady	4	BN2, BN4, BN6
3	NT605041	€0.84	NUT, steady post	4	
4	7H4429	€2.52	BUSH, felt	4	
5	NA		BOLT, plate & strg lever to axle	4	BN1
7	AJD8106Z	€0.96	NUT	4	
	661-930		NA LOCKTAB	2	
5	NA		BOLT, plate & strg lever to axle, long	2	
6	BH607241	€2.28	BOLT, plate & strg lever to axle, short	2	BN2, BN4, BN6
7	FNZ507	€1.68	NUT	4	
	661-930		NA LOCKTAB	2	
9	NA		BOLT, plate to swivel axle, BSF	4	BN1 as fitted
	NA		BOLT, plate to swivel axle, UNF	4	
	NA		BOLT, plate to swivel axle	4	BN2, BN4, BN6
	NA		LOCKTAB	2	BN1
	NA		LOCKTAB	2	BN2
10	661-930		NA LOCKTAB	2	
11	GHF333	€0.72	WASHER, locking	4	BN4, BN6
12	519-025	NA	BRAKE SHOE SET, front	1	BN1
13	585-260	€159.00	LINER & RIVET SET, brake shoe	1	
12	8G8159	€88.92	BRAKE SHOE SET, front	1	BN2, BN4, BN6
13	585-270	NA	LINING & RIVET SET, brake shoe	1	
14	585-271	€1.20	RIVET, brake shoe	48	(all)
16	582-850	€12.60	SPRING, brake shoe return	4	BN1
	582-860	NA	SPRING, brake shoe return	4	BN2, BN4, BN6 wire whls
	582-850	€12.60	SPRING, brake shoe return	4	BN4, BN6 disc whls
17	7H4584	€50.88	WHEEL CYLINDER, 1" bore, RH*	2	BN1 to C.E.221403
	7H4583	€50.88	WHEEL CYLINDER, 1" bore, LH*	2	
18	513-015	€11.52	REPAIR KIT, wheel cyl, 1" bore	2	
	7H4643	€54.72	WHEEL CYLINDER, 7/8" bore, RH (kit is for 4 cylinders)	2	BN1 from C.E.221404 & BN2
	7H4644	€54.72	WHEEL CYLINDER, 7/8" bore, LH	2	
	021-145	€14.64	REPAIR KIT, wheel cyl, 7/8" bore	1	
	17H4003	€60.12	WHEEL CYLINDER, RH (kit for 4 whl. cyls.)	2	BN4, BN6 disc wheels
	17H4004	€60.12	WHEEL CYLINDER, LH	2	
	513-116	€13.44	REPAIR KIT, wheel cylinder	1	
	7H4584	€50.88	WHEEL CYLINDER, RH (kit for 2 whl. cyls.)	2	BN4, BN6 wire wheels
	7H4583	€50.88	WHEEL CYLINDER, LH	2	
	513-015	€11.52	REPAIR KIT, wheel cylinder	2	

ill.	Part Number	Price €ea.	Description	Req.	Details
21	GHF331	NA	WASHER, locking	8	BN1, BN2
	GHF321	€1.08	WASHER, shakeproof	8	BN4, BN6 wire wheels
	GHF332	€0.84	WASHER, locking	8	BN4, BN6 disc wheels
22	3H2428	€2.04	BLEED NIPPLE	4	
24	SMP100030	€1.68	DUST CAP, bleed nipple	4	
25	021-578	€21.24	PIPE, brake	2	BN1, BN2
	021-578	€21.24	PIPE, brake, 14" long	2	BN4, BN6 wire wheels
	021-572	€15.72	PIPE, brake, 10" long	2	BN4, BN6 disc wheels
26	586-025	NA	BRAKE DRUM	2	BN1
	7H1825ALF	€358.80	BRAKE DRUM, alfin style	2	BN1 wire wheels, to C.E.228046
	1B4483	€285.60	BRAKE DRUM	2	BN2, BN4 to C.E.68959 wire wheels
	021-543	NA	BRAKE DRUM	2	BN4 from C.E.68960, BN6 wire wheels
	1B7526	€81.24	BRAKE DRUM	2	BN4, BN6 disc wheels
28	SF604061	€0.96	SCREW, drum to hub	4	

Note: Early original wheel cylinders had ball type bleeders which are no longer available.

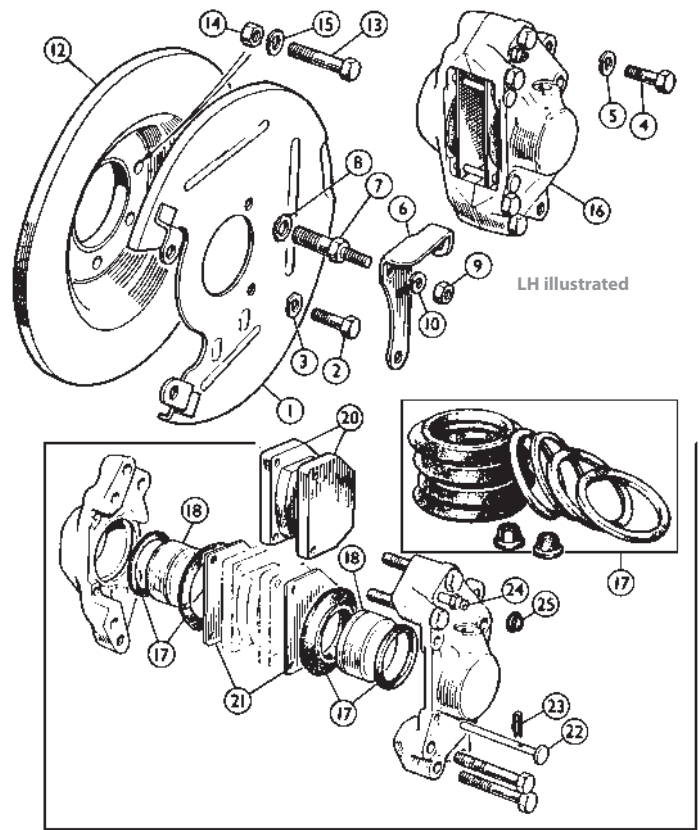
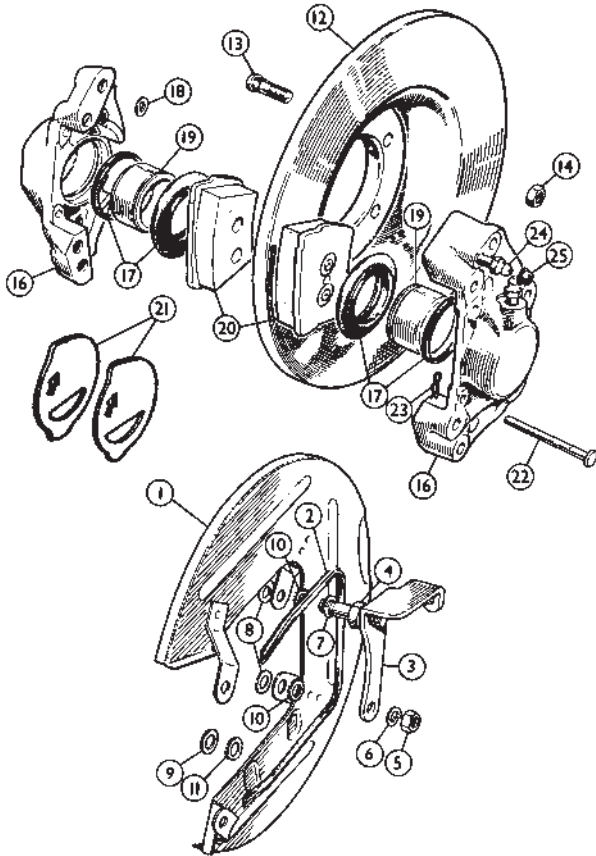

iii. Part Number Price €ea. Description Req. Details
Front Disc Brakes BN7, BT7, BJ7; BJ8 to (c)26704

iii.	Part Number	Price €ea.	Description	Req.	Details
1	586-060	€110.88	COVER ASSEMBLY, dust, RH	1	BN7 from (c) 9450 disc whls & from (c) 9453 wire wheels, BT7 from (c) 9088 disc whls & from (c)9090 wire wheels
	586-050	NA	COVER ASSEMBLY, dust, LH	1	
2	517-020	NA	SEAL, dust cover, rubber	2	
3	586-035	€13.56	BRACKET, brake hose, RH	1	
	586-055	€17.88	BRACKET, brake hose, LH	1	
4	BTC125	€15.60	BOLT, caliper to swivel axle	4	
5	GHF201	€0.84	NUT	4	
6	GHF332	€0.84	WASHER, locking	4	
7	GHF334	€1.32	WASHER, locking	4	
8	WP9	€2.04	WASHER, plain	4	
9	NA	NA	WASHER, plain	2	BN7 from (c) 9450 disc whls & from (c) 9453 wire
10	NA	NA	WASHER, shakeproof	2	wheels, BT7 from (c)
11	NA	NA	WASHER, shakeproof	6	9088 disc whls & from (c)9090 wire wheels
12	BTC104	€41.64	DISC, brake	2	
13	BTC103	€6.12	STUD, disc to hub	10	
14	662-025	€1.56	NUT, self-locking	10	
16	BTC260	€308.40	CALIPER ASSEMBLY, RH	1	
	BTC261	€308.40	CALIPER ASSEMBLY, LH	1	
Note: Do not attempt to 'split' the callipers (as shown in the illustration!).					
17	8G8279	€24.60	REPAIR KIT, for 2 callipers	1	original callipers only
18	583-820	€2.28	SEAL, between caliper halves	2	(not in repair kit)
19	17H4960	€19.80	PISTON, caliper, mild steel, nitride finish	4	
	17H4960SS	€25.56	PISTON, caliper, stainless steel	4	
20	GBP116AF	€41.64	BRAKE PAD SET, semi-metallic	1	Classic Gold
	GBP116CM	€33.96	BRAKE PAD SET, ceramic	1	Classic Gold
	582-908	€26.04	FITTING KIT, brake pad	1	#21, 22, 23
21	BHA4195	€4.56	SHIM, brake pad, anti-squeal	4	
22	011368A	€2.88	PIN, pad retaining	4	
23	011369A	€0.96	CLIP, pin	4	
24	601959	€3.96	BLEED SCREW	2	
25	SMP100030	€1.68	DUST CAP, bleed screw	2	

iii. Part Number Price €ea. Description Req. Details
Front Disc Brakes BJ8 from (c)26705 on

iii.	Part Number	Price €ea.	Description	Req.	Details
1	586-070	€95.64	COVER ASSEMBLY, dust, LH	1	
	586-080	€95.64	COVER ASSEMBLY, dust, RH	1	
2	NA	NA	BOLT, dust cover to swivel axle	4	
3	GHF332	€0.84	WASHER, locking	4	
4	SH604031	€2.28	BOLT, dust cover to caliper	4	
5	GHF331	€0.84	WASHER, locking	4	
6	586-065	€17.88	BRACKET, brake hose, LH	1	
	586-075	€17.88	BRACKET, brake hose, RH	1	
7	BTC379	€12.96	BOLT, caliper to swivel axle	4	
8	NA	NA	WASHER, shakeproof	4	
9	GHF201	€0.84	NUT	4	
10	GHF332	€0.84	WASHER, locking	4	
12	BTC371	€84.60	DISC, brake, aftermarket	2	
13	53K1048	€1.20	BOLT, disc to hub	10	
14	GHF202	€0.72	NUT	10	
15	GHF333	€0.72	WASHER, locking	10	
16	311852	€110.04	CALIPER ASSEMBLY, LH	1	new reproduction callipers
	311851	€110.04	CALIPER ASSEMBLY, RH	1	
	182-885	€39.24	PISTON & REPAIR KIT	1	
	519731	€39.12	REPAIR KIT, TRW/Lucas	1	
	519731Z	€19.80	REPAIR KIT, aftermarket	1	
	157685	€24.00	PISTON, forged steel	4	
	157685SS	€20.52	PISTON, stainless steel (alternate)	4	
17	601960	€70.32	REPAIR KIT, TRW/Lucas	1	original callipers
	583-001	NA	REPAIR KIT, aftermarket	1	
	510792	€16.68	PISTON, mild steel	4	
	510792SS	€25.32	PISTON, stainless steel	4	
20	TT31501G	€63.84	BRAKE PAD SET, "Greenstuff"	1	see accessories section
	GBP114	€26.64	BRAKE PAD SET, semi-metallic, Classic Gold	1	
	GBP114CM	€45.84	BRAKE PAD SET, ceramic, Classic Gold	1	
	GRPFK1	€15.60	FITTING KIT, brake pad (#21, 22, 23)	1	
21	27H2953	€3.36	SHIM, brake pad, anti-squeal	4	
22	011368A	€2.88	PIN, pad retaining	4	
23	011369A	€0.96	CLIP, pin	4	
24	601959	€3.96	BLEED SCREW	2	
25	SMP100030	€1.68	DUST CAP, bleed screw	2	

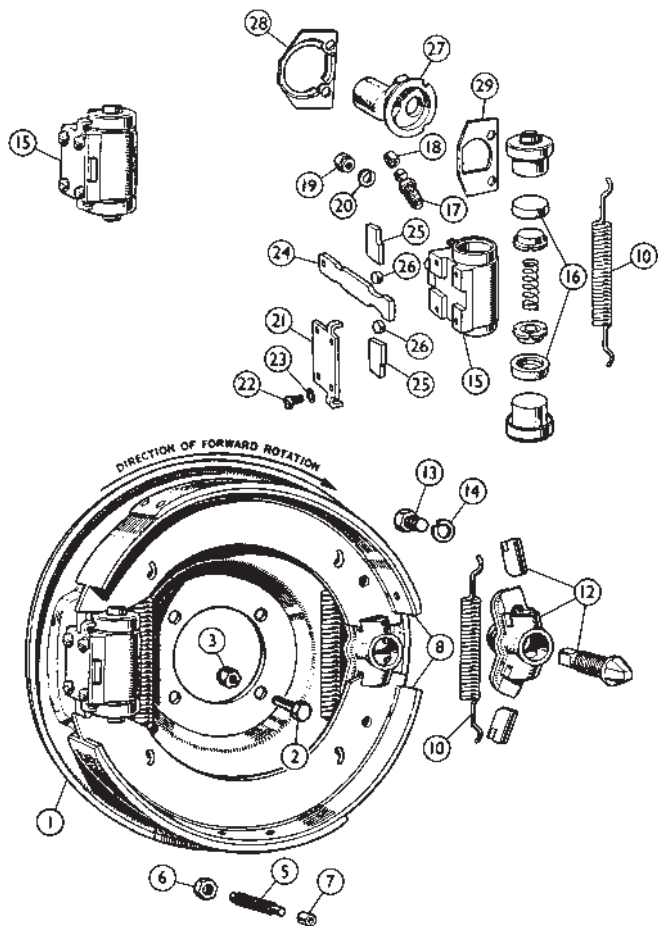

iii. Part Number Price €ea. Description Req. Details

Rear Brakes; BN1 to C.E.221535 (Spiral Bevel Axle)

Part Number	Price €ea.	Description	Req.	Details
1	NA	BACKPLATE	2	
2	NA	BOLT, plate to axle case	8	
3	AJD8106Z	€0.96 NUT, bolt	8	
	NA	LOCK TAB	4	
5	586-015	€6.12 POST, steady	4	see adjusting instructions online
6	NT605041	€0.84 NUT, steady post	4	
7	7H4429	€2.52 BUSH, felt	4	
8	021-167	NA BRAKE SHOE SET, rear	1	
	585-265	€158.16 LINING & RIVET SET, brake shoe	1	
	585-271	€1.20 RIVET, brake shoe	48	
10	582-970	€11.76 SPRING, brake shoe return	4	
12	582-940	NA ADJUSTER ASSEMBLY	2	
13	NA	SCREW, adjuster to backplate	4	
14	GHF333	€0.72 WASHER, locking	4	
15	7H4598	€57.60 WHEEL CYLINDER ASSEMBLY, RH	1	
	7H4597	€57.60 WHEEL CYLINDER ASSEMBLY, LH	1	
16	513-015	€11.52 REPAIR KIT, wheel cylinder	2	
17	3H2428	€2.04 BLEED SCREW	2	
18	SMP100030	€1.68 DUST CAP, bleed screw	2	
19	NA	NUT, nyloc, cylinder to brake plate	4	
20	NA	WASHER, thackery	2	
21	582-905	€39.96 COVER PLATE	2	
22	NA	SCREW, plate to cylinder	8	
23	NA	WASHER, shakeproof	8	
24	582-915	NA DRAWLINK, handbrake	2	
25	582-955	NA TAPPET, handbrake	4	
26	583-005	NA ROLLER	4	
27	583-007	€19.68 DUST COVER, drawlink, LH	1	
	583-006	€19.68 DUST COVER, drawlink, RH	1	
28	582-920	NA RETAINER PLATE, dust cover	2	
29	582-930	NA SPACER	2	
	586-025	NA BRAKE DRUM	2	
	7H1825ALF	€358.80 BRAKE DRUM, Alfin style	2	BN1 to C.E.221535

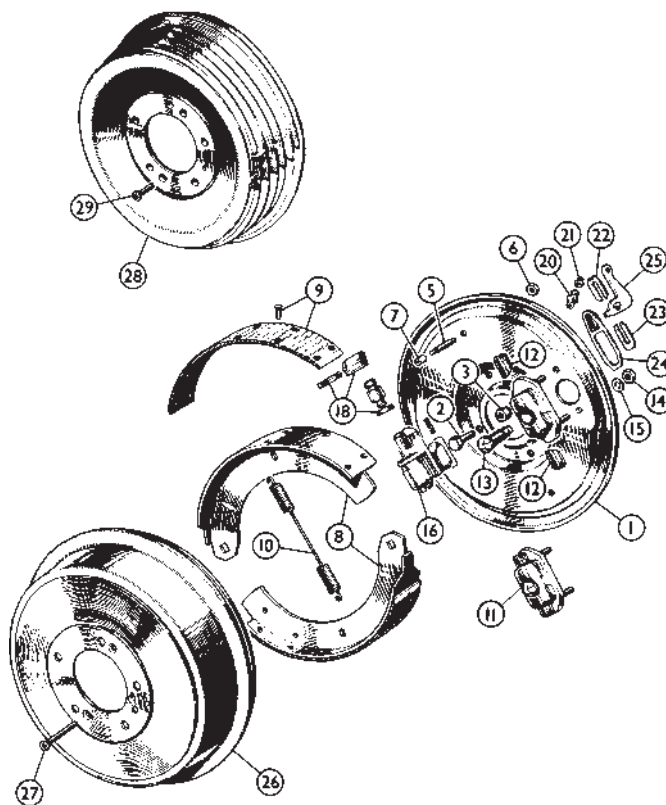

iii. Part Number Price €ea. Description Req. Details

Rear brakes; from BN1 C.E.221536 on (Hypoid Axle)

Part Number	Price €ea.	Description	Req.	Details
1	NA	BACKPLATE	2	
2	53K1048	€1.20 BOLT, plate to axle case	8	
3	GHF223	€1.56 NUT, nyloc	8	
5	586-015	€6.12 POST, steady	4	(see adjusting instructions online)
6	NT605041	€0.84 NUT, steady post	4	
7	7H4429	€2.52 BUSH, felt	4	
8	LKKB1088	€51.72 BRAKE SHOE SET, rear	1	
9	585-270	NA LINING & RIVET SET	1	
	585-271	€1.20 RIVET, brake shoe	48	
10	7H4596	€9.96 SPRING, brake shoe return	4	
11	7H4997	€82.44 BRAKE ADJUSTER, Girling	2	
12	NA	TAPPET, adjuster	4	
13	505085	NA WEDGE, adjuster	2	
14	GHF202	€0.72 NUT, adjuster to plate	4	
15	GHF333	€0.72 WASHER, locking	4	
16	7H4988	€65.28 WHEEL CYLINDER, Classic Gold	2	BN1 from C.E.221536,
18	513-093	€4.68 REPAIR KIT, wheel cylinder	1	BN2, BN4, BN6
	GWC1118	€73.68 WHEEL CYLINDER, TRW brand	2	
	GWC1118Z	€45.36 WHEEL CYLINDER, aftermarket	2	BN7, BT7, BJ7, BJ8
	18G9065	€25.56 REPAIR KIT, wheel cylinder	1	
20	3H2428	€2.04 BLEED SCREW	2	
21	SMP100030	€1.68 DUST CAP, bleed screw	2	
	GRSP2862	€20.88 FITTING KIT, wheel cylinder	1	for 2 whl. cylinders
22	505091A	NA SPRING, retaining cylinder	2	
23	7H4907	€7.92 PLATE, locking retaining spring	2	
24	505093A	€5.28 COVER, dust, cylinder	2	
25	585-590	€30.48 LEVER ASSEMBLY, handbrake	2	
26	1B7490	NA BRAKE DRUM	2	BN4-BJ8 disc wheels
27	CMZ428	€1.44 SCREW, drum to hub	4	
28	586-030	NA BRAKE DRUM	2	BN1 from C.E.221536,
	1B7526ALF	€316.80 BRAKE DRUM, Alfin style	2	BN2 wire wheels
29	SF604081	€1.08 SCREW, drum to hub	4	
	1B7526	€81.24 BRAKE DRUM	2	BN4-BJ8 wire wheels
	SF604081	€1.08 SCREW, drum to hub	4	

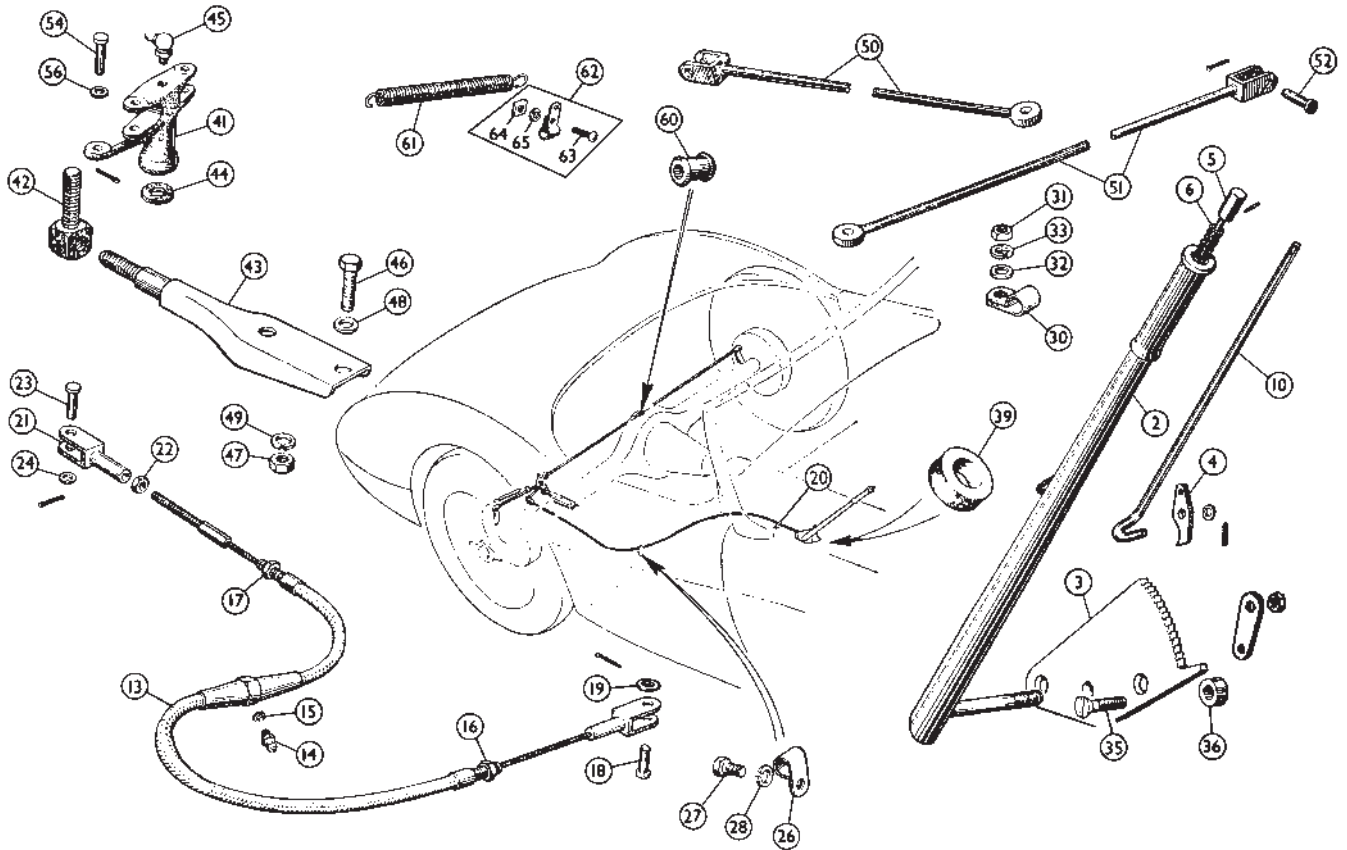

Part Number	Price €ea.	Description	Req.	Details
Handbrakes				
11B5282	€250.80	NA HANDBRAKE LEVER ASSEMBLY	1	BN1 to C.E149902
2		NA HANDBRAKE LEVER ASSEMBLY	1	BN1 from C.E149903, BN2
3		NA HANDBRAKE LEVER ASSEMBLY	1	BN4-BJ8
4		NA LEVER, handbrake	1	
5		NA PLATE, ratchet	1	BN1 to C.E149902
17H787	€28.08	NA PLATE, ratchet	1	BN1 from C.E149903, BN2
6		NA PAWL, ratchet	1	BN1, BN2
7		NA PAWL, ratchet	1	BN4-BJ8
8		BUTTON	1	BN1, BN2
9		BUTTON	1	BN4-BJ8
10		SPRING	1	
11		ROD, for pawl	1	BN1, BN2
12		ROD, for pawl	1	BN4-BJ8
13		CABLE, handbrake	1	BN1, BN2
14		CABLE, handbrake	1	BN4-BJ8
15		NIPPLE, grease, BSF	1	BN1, BN2
16		NIPPLE, grease, UNF	1	BN4-BJ8
17		WASHER, locking	1	
18		NUT, cable, front (included with cable)	1	
19		SPRING CLIP, cable	2	
20		NUT, cable, rear (not incl. with cable)	1	
21		CLEVIS PIN	1	BN1, BN2
22		CLEVIS PIN	1	BN4-BJ8
23		WASHER, plain	1	BN1, BN2
24		WASHER, plain	1	
25		WASHER, locking	1	
26		CLIP, cable to heelboard	1	
27		BOLT, clip to heelboard	1	BN4-BJ8
28		WASHER, locking	1	
29		CLIP, cable to rear floor	1	
30		NUT	1	BT7 from (c)10475, BJ7, BJ8
31		WASHER, plain	1	
32		WASHER, plain	1	
33		WASHER, locking	1	
34		SCREW, lever to frame bracket	2	BN1 to C.E.149902
35		SCREW, lever to frame bracket	2	BN1 from C.E.149903
36		SPACER	2	BN2-BJ8
37		SEAL, lever to frame	1	BJ7, BJ8

Part Number	Price €ea.	Description	Req.	Details
41		NA LEVER, balance	1	
42		NA CARRIER, balance lever	1	
43		NA SUPPORT	1	
44		NA RING, felt	1	
45		NA NIPPLE, grease, BSF	1	
46		NA BOLT, support to axle	2	BN1 to C.E.221535
47	€0.72	AJD8105Z NUT, BSF	2	
48	€0.60	GHF301 WASHER, plain	2	
49	€0.84	GHF332 WASHER, locking	2	
50		NA CROSS ROD, short, RH	1	
		NA CROSS ROD, long, LH	1	
51	€109.20	021-699 LEVER, balance	1	
52	€21.36	021-715 CARRIER, balance lever	1	
53		021-720 NA SUPPORT	1	
54		021-720 NA RING, felt	1	
55	€3.24	021-747 LN30041 NIPPLE, grease, UNF	1	BN1 from C.E.221536,
56	€2.16	LN30041 NIPPLE, grease, UNF	1	BN2-BJ8
57	€0.72	GHF120 BOLT, support to axle	2	
58	€0.84	GHF201 NUT, UNF	2	
59	€0.60	GHF301 WASHER, plain	2	
60	€0.84	GHF332 WASHER, locking	2	
61	€28.56	021-708 CROSS ROD, short, RH	1	
62	€32.88	021-709 CROSS ROD, long, LH	1	
63	€2.88	2K6930 PIN, fork end to backplate lever	2	
64		NA PIN, cross rod to balance lever	2	
65	€1.08	2K5291 RING, felt	8	
66	€3.00	1B5329 GROMMET, cross rod steady, rubber	1	
67	€5.76	021-721 SPRING, pull-off	2	
68	€10.20	021-757 CLIP ASSY	2	BN1 from C.E.221536,
69		NA SCREW	2	BN2-BJ8
70		NA NUT	2	
71	€0.84	GHF331 WASHER, locking	2	

iii. Part Number Price €ea. Description Req. Details

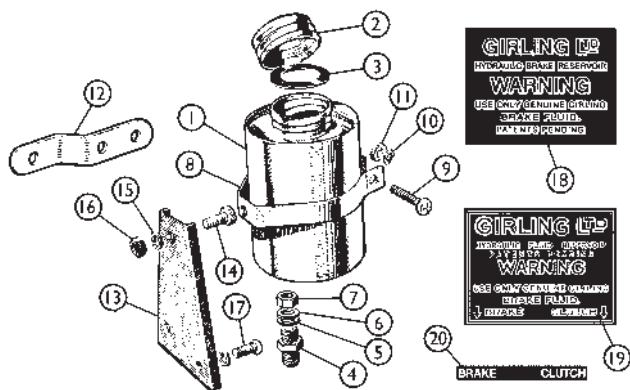

Brake Reservoir (All Models Except BN4 up to C.E.48862)

3H920	€79.20	RESERVOIR, single outlet (with decal #18)	1	BN1, BN2
1 114530	€74.76	RESERVOIR, dual outlet (with decal #19)	1	BN4 from C.E.48863, BN6, BN7, BT7 thru early 1959
ACB5856	NA	RESERVOIR, dual outlet (with "Brake" & "Clutch" decal)	1	BN7, BT7 from mid 1959, BJ7, BJ8
2 596-211	€21.48	CAP, filler, knurled edge	1	thru early 1959
596-212	€21.48	CAP, filler, faceted edge	1	from mid 1959
3 106095	€1.44	SEAL, filler cap, stock type	1	
582-505	€9.00	SEAL, splash-proof	1	improved replacement, incl. w/tanks
4	NA	ADAPTOR	1/2	
5 3H693	€1.56	WASHER, copper	1/2	
582-987	€2.52	WASHER, stainless & Viton, repl. (replaces washers no 5 & 6)	2/4	quantity increases for dual supply tanks
6	NA	WASHER, sealing adaptor	1/2	
7	NA	NUT, adaptor	1/2	
8 582-985	€9.12	CLAMP ASSEMBLY, supply tank	1	
9 PMZ314	€0.72	SCREW	1	
10 GHF331	€0.84	LOCKWASHER	1	
11 GHF206	€1.32	NUT	1	
	NA	BRACKET, supply tank, LHD	1	BN1, BN2
	NA	BRACKET, supply tank, RHD	1	
12 596-085	€12.48	BRACKET, supply tank, LHD	1	BN4 from C.E.48863
13 582-965	€13.08	BRACKET, supply tank, RHD	1	BN6, BN7, BT7, BJ7, BJ8
14 SH604041	€0.84	BOLT, clamp to bracket and	1	
15 GHF200	€0.96	NUT	1	
16 GHF331	€0.84	LOCKWASHER	1	
17 SH604031	€2.28	BOLT, bracket to body	2	
18 216-495	€3.48	DECAL, single outlet tank*	1	BN1, BN2
19 216-496	€4.20	DECAL, dual outlet tank*	1	BN4 from C.E.48863, BN6, BN7, BT7 thru early 1959
20 582-983	€2.76	DECAL "Brake" "Clutch"*	1	from mid 1959 on

iii. Part Number Price €ea. Description Req. Details

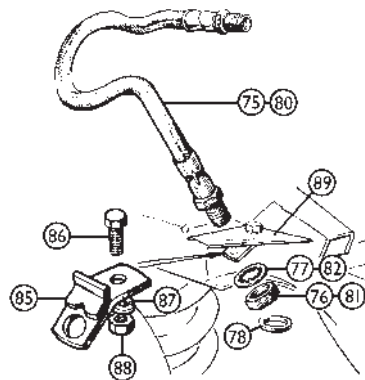

Front Brake Hoses

75 GBH206	€22.80	HOSE	2	BN1, BN2, BN4, BN6
GBH206Z	€14.04	HOSE, aftermarket	2	
584-068	€81.84	COBALT HOSE SET	1	BN1, BN2, BN4
584-098	€55.56	COBALT HOSE SET	1	BN6
76 NT606041	€1.08	NUT, hose to pipe	2	BN1, BN2, BN4, BN6
77 GHF323	€0.96	WASHER, shakeproof	2	
78 233220A	€1.68	WASHER, copper, hose to cylinder	2	
80 GBH166	€21.36	HOSE, Delphi brand	2	BN7, BT7, BJ7, BJ8
584-058	€89.76	COBALT HOSE SET	1	BN7
584-078	€73.80	COBALT HOSE SET	1	BT7, BJ7, BJ8
80 GBH166Z	€15.36	HOSE, aftermarket	2	
81 NT606041	€1.08	NUT, hose to pipes	4	BN7, BT7, BJ7, BJ8
82 GHF323	€0.96	WASHER, shakeproof	4	
85 587-335	€20.88	BRACKET, front brake hose	2	
86 SH604041	€0.84	BOLT, bracket to body	2	
87 GHF331	€0.84	WASHER, locking	2	
88 GHF200	€0.96	NUT	2	
89 587-350	€38.64	BRACKET	2	

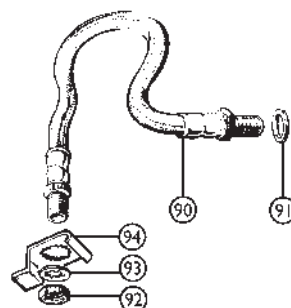

Rear Brake Hoses

90 GBH206	€22.80	HOSE, rear	1	BN1, BN2, BN4, BT7,
GBH206Z	€14.04	HOSE, rear, aftermarket	1	BJ7, BJ8
584-050	€14.76	HOSE, rear	1	BN6, BN7
91 233220A	€1.68	WASHER, copper, hose to 3-way	1	
92 NT606041	€1.08	NUT, hose to pipe	1	
93 GHF323	€0.96	WASHER, shakeproof	1	
94	NA	LOCKPLATE	1	

iii. Part Number Price €ea. Description Req. Details

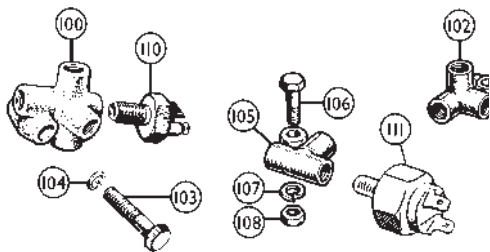

Brake Fittings

Pipe Connectors: Engine Bay

100	589-010	NA	UNION, front, 5-way	1	BN1, BN2, BN4, BN6;
	279412K	€42.36	UNION w/switch (replacement)	1	BN7, BT7, BJ7 (non-servo)
102	565719A	€34.80	CONNECTOR, front, 4-way	1	BN7, BT7, BJ7, BJ8 (servo)
103	BH604101	€0.96	BOLT, connector to body	1	
104	GHF331	€0.84	WASHER, locking	1	
105	BTB657	€27.96	CONNECTOR, front, 3-way	1	
106	BH604101	€0.96	BOLT, connector to wheel arch	1	BN7, BT7, BJ7, BJ8 (servo)
107	GHF331	€0.84	WASHER, locking	1	
108	GHF200	€0.96	NUT	1	
110	13H2303	€10.80	SWITCH, brake lights, screw terminals	1	tapered pipe thread
	C16062A	€7.44	SWITCH, brake lights, Lucar terminals	1	tapered pipe thread
			*Used with 5-way union, illus. no. 100.		
111	27H4754	€12.00	SWITCH, brake lights, Lucar terminals	1	tapered seat
			**Used with 3-way connector, no. 105.		

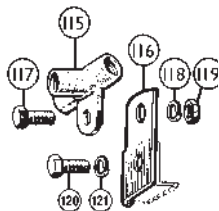

Pipe Connectors: Rear Axle

115	101070	€29.64	CONNECTOR, rear, 3-way	1	
116	NA		BRACKET, for 3-way connector	1	
117	GHF120	€0.72	BOLT, connector to bracket	1	
118	GHF332	€0.84	WASHER, locking	1	
119	GHF201	€0.84	NUT	1	
120	NA		BOLT, bracket to axle, BSF	1	BN1 to C.E.221535
	SH605051	€1.80	BOLT, bracket to axle, UNF	1	BN1 from C.E.221536, BN2
121	GHF332	€0.84	WASHER, locking	1	

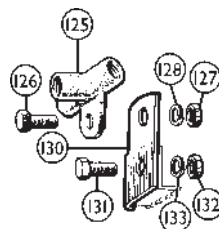

**Pipe Connectors: Rear Axle
BN4, BN6, BN7, BT7, BJ7, BJ8**

125	101070	€29.64	CONNECTOR, rear, 3-way	1	
126	GHF120	€0.72	BOLT, connector to axle case	1	
127	GHF201	€0.84	NUT	1	BN4, BT7, BJ7, BJ8
128	GHF332	€0.84	WASHER, locking	1	
130	NA		EXTENSION, connector to axle case	1	
131	GHF120	€0.72	BOLT, connector to extension & extension to axle case	2	BN6, BN7
132	GHF201	€0.84	NUT	2	
133	GHF332	€0.84	WASHER, locking	2	

iii. Part Number Price €ea. Description Req. Details

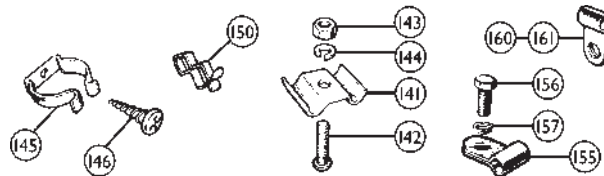

Brake Pipe Clips

141	2H400	NA	CLIP, tank to m/cylinder pipe, LHD	1	BN1, BN2
		€2.40	CLIP, tank to m/cylinder pipe, LHD	1	BN4 from C.E.48863; BN6 thru BJ8
142	PMZ307	€1.20	SCREW, for clip	1	
143	GHF206	€1.32	NUT	1	
144	GHF331	€0.84	WASHER, locking	1	
145	NA		CLIP, m/cylinder to 5-way pipe, RHD	1	BN4, BN6; BN7, BT7, BJ7 (non-servo)
146	PMZ305	€0.84	SCREW, clip	1	BN4, BN6; BN7, BT7, BJ7 (non-servo)
150	6K35	€1.44	CLIP, brake pipes	A/R	
155	NA		CLIP, LH rear brake pipe to axle	1	BN1 from C.E.221536, BN2 thru BJ8
156	SH604041	€0.84	BOLT, clip	1	
157	GHF331	€0.84	WASHER, locking	1	
160	NA		CLIP, on gear carrier stud	1	BN1 to C.E.221535
161	NA		CLIP, on gear carrier stud	1	BN1 from C.E.221536, BN2 thru BJ8
165	PCR307	€2.16	CLIP, servo to 4-way pipe	1	BN7, BT7, BJ7, BJ8 (w servo)

ill. Part Number Price €ea. Description Req. Details

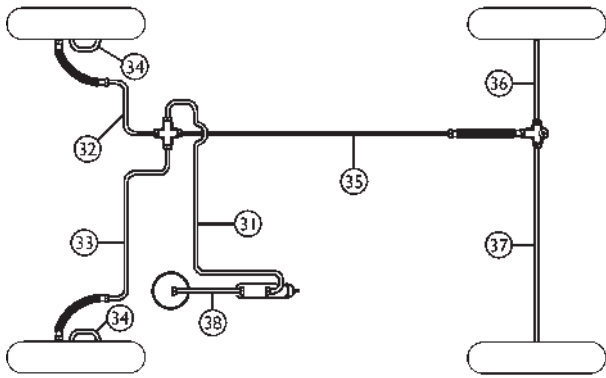

Brake Pipes: BN1, BN2

585-407	€191.04	BRAKE PIPE SET	1	RHD
585-408	€182.40	BRAKE PIPE SET	1	LHD
31	NA	PIPE, m/cyl.to 5-way connector	1	RHD
585-420	NA	PIPE, m/cyl.to 5-way connector	1	LHD
32	585-425	NA PIPE, 5-way to RH front hose	1	
33	585-430	NA PIPE, 5-way to LH front hose	1	
34	021-578	€21.24 PIPE, bridging front brake	2	
35	585-435	NA PIPE, 5-way connector to rear hose	1	
36	585-440	NA PIPE, 3-way to RH rear brake	1	
37	585-445	NA PIPE, 3-way to LH rear brake	1	
38	585-412	€30.96 PIPE, tank to master cylinder*	1	RHD
585-411	€34.20	PIPE, tank to master cylinder*	1	LHD

*Tank to master cylinder pipes are not in brake pipe sets.

ill. Part Number Price €ea. Description Req. Details

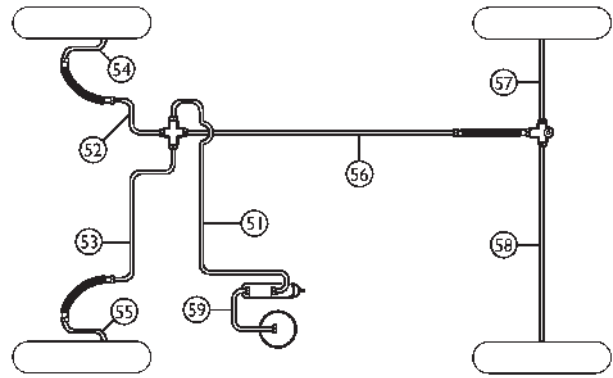

Brake Pipes: BN7, BT7, BJ7 (non-servo)

585-427	€175.68	BRAKE PIPE SET	1	RHD
GL5042	€196.80	BRAKE PIPE SET	1	LHD
51	NA	PIPE, m/cyl.to 5-way connector	1	RHD
585-465	NA	PIPE, m/cyl.to 5-way connector	1	LHD
52	585-470	€20.64 PIPE, 5-way to RH front hose	1	
53	585-475	NA PIPE, 5-way to LH front hose	1	
54	585-415	NA PIPE, RH front hose to caliper	1	
55	585-450	NA PIPE, LH front hose to caliper	1	
56	585-480	NA PIPE, 5-way connector to rear hose	1	
57	585-485	NA PIPE, 3-way to RH rear brake	1	
58	585-490	NA PIPE, 3-way to LH rear brake	1	
59	585-575	€29.88 PIPE, tank to master cylinder*	1	LHD
585-455	€27.24	PIPE, tank to master cylinder*	1	RHD

*Tank to master cylinder pipes are not in brake pipe sets.

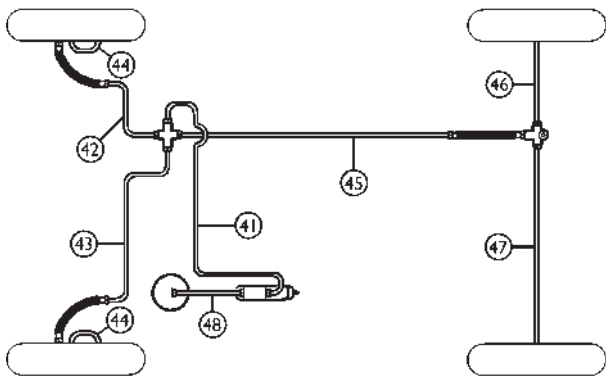

Brake Pipes: BN4, BN6

585-417	€158.16	BRAKE PIPE SET	1	RHD
GAC5079	€196.80	BRAKE PIPE SET	1	LHD
41	NA	PIPE, m/cyl.to 5-way connector	1	RHD
585-465	NA	PIPE, m/cyl.to 5-way connector	1	LHD
42	585-470	€20.64 PIPE, 5-way to RH front hose	1	
43	585-475	NA PIPE, 5-way to LH front hose	1	
44	021-578	€21.24 PIPE, bridging front brake	2	wire wheels
021-572	€15.72	PIPE, bridging front brake	2	disc wheels
45	585-480	NA PIPE, 5-way connector to rear hose	1	
46	585-485	NA PIPE, 3-way to RH rear brake	1	
47	585-490	NA PIPE, 3-way to LH rear brake	1	
48	585-575	€29.88 PIPE, tank to master cyl. LHD*	1	} BN4 from C.E.48863, } BN6
585-455	€27.24	PIPE, tank to master cyl. RHD*	1	

*Tank to master cylinder pipes are not in brake pipe sets.

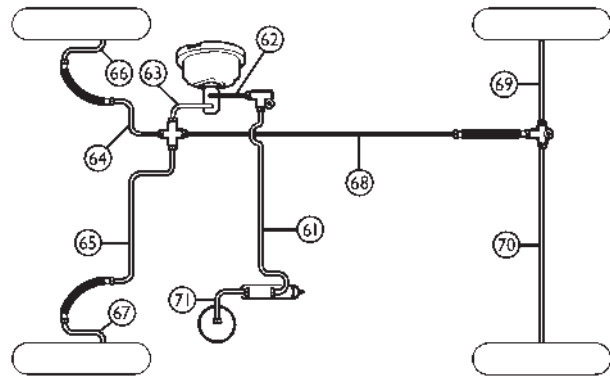

Brake Pipes: BN7, BT7, BJ7, BJ8 (with servo)

		NA	BRAKE PIPE SET	1	RHD
		GAC5041L	€189.36 BRAKE PIPE SET	1	LHD
61	NA	PIPE, m/cyl.to 3-way connector	1	RHD	
585-545	NA	PIPE, m/cyl.to 3-way connector	1	LHD	
62	585-565	NA PIPE, 3-way connector to servo	1		
63	585-555	NA PIPE, servo to 4-way connector	1		
64	585-470	€20.64 PIPE, 4-way to RH front hose	1		
65	585-475	NA PIPE, 4-way to LH front hose	1		
66	585-415	NA PIPE, RH front hose to caliper	1		
67	585-450	NA PIPE, LH front hose to caliper	1		
68	585-480	NA PIPE, 4-way connector to rear hose	1		
69	585-485	NA PIPE, 3-way to RH rear brake	1		
70	585-490	NA PIPE, 3-way to LH rear brake	1		
71	585-575	€29.88 PIPE, tank to master cylinder*	1	LHD	
585-455	€27.24	PIPE, tank to master cylinder*	1	RHD	

*Tank to master cylinder pipes are not in brake pipe sets.

iii. Part Number Price €ea. Description

Req. Details

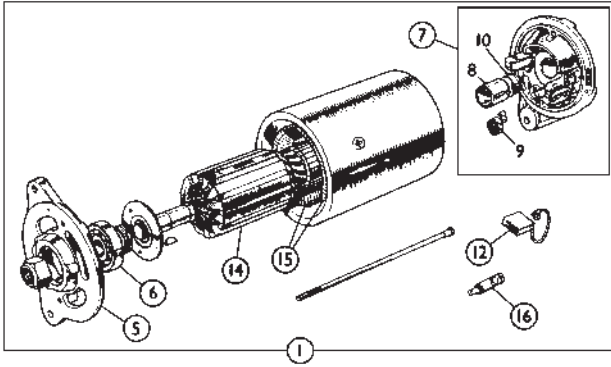

Dynamo: Lucas 22456, 22483, 22530

1	540-360	NA	DYNAMO (22456A-D)	1	BN1 to C.E.223154
		NA	DYNAMO (22483A-D)	1	BN1 from C.E.223155, BN2, BN4, BN6
		NA	DYNAMO (22530A-B)	1	BN7, BT7, BJ7
5	540-370	NA	BRACKET, drive end	1	
6	125-200	€15.00	BEARING, drive end	1	
7		NA	BRACKET, commutator end	1	22456A-D, 22483A-D
		NA	BRACKET, commutator end	1	22519A, 22530A-B
		NA	BRACKET, commutator end	1	22489B-E
8	148-000	€16.68	BUSH, commutator end	1	22456A-D, 22519A
	330-050	€8.64	BUSH, commutator end	1	22483A-D, 22489B-E, 22530A-B
9	549-010	NA	SPRING SET	1	22456A-D, 22483A-D
	549-020	€18.72	SPRING SET	1	22489B-E, 22519A, 22530A-B
	147-900	€57.36	OILER	1	22456A-D, 22483A-D, 22519A
10		NA	OILER	1	22489B-E, 22530A-B
12	7H5016	€9.36	BRUSH SET	1	22456A-D, 22483A-D
	17H2472	€7.80	BRUSH SET	1	22489B-E, 22519A, 22530A-B
14	148-150	NA	ARMATURE	1	
15		NA	FIELD COIL SET	1	
16		NA	TERMINAL	1	22456A-D, 22483A-D, 22519A
		NA	TERMINAL	1	22489B-E, 22530A-B

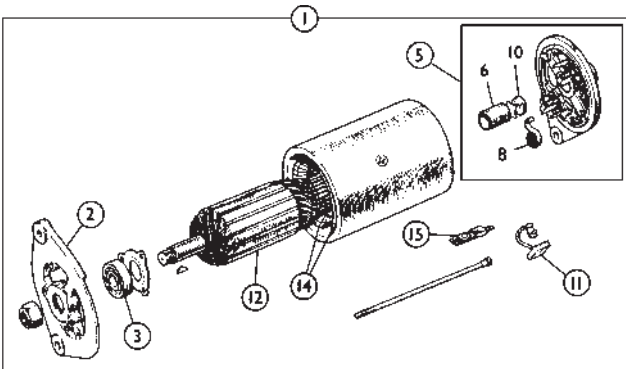

Dynamo: Lucas 22900

1	GEU1104	€308.40	DYNAMO (22900A-J)	1	BJ8
2		NA	BRACKET, drive end	1	22900B
		NA	BRACKET, drive end	1	22900D-E
3	125-100	€12.48	BEARING, drive end	1	
5		NA	BRACKET, commutator end	1	
6	873-625	€3.96	BUSH, commutator end	1	
8	549-020	€18.72	SPRING SET	1	
10	032307	€2.52	OILER, felt	1	
11	GGB101	€12.72	BRUSH SET	1	
12		NA	ARMATURE	1	22900A-F
	162-840	NA	ARMATURE	1	22900H-J
14		NA	FIELD COIL SET	1	
15		NA	TERMINAL	1	

iii. Part Number Price €ea. Description

Req. Details

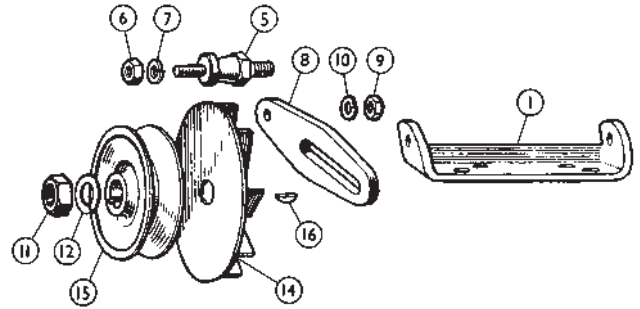

Dynamo Mountings, 100-4

1	021-903	€66.96	BRACKET, dynamo mounting	1	
5	031-403	NA	PILLAR, dynamo adjusting link	1	
6		NA	NUT, pillar to front plate	1	
7		NA	WASHER, locking	1	
8	031-406	€17.28	ADJUSTING LINK (replacement)	1	
9		NA	NUT	1	
10		NA	WASHER	1	
11	AJD8207Z	€2.16	NUT, BSF	1	original dynamo
	NT607041	€1.80	NUT, UNF	1	replacement dynamo
12	146-500	NA	WASHER, locking	1	
14	1B2178	NA	FAN	1	
15	031-402	€53.40	PULLEY	1	
16	WKN405	€1.80	KEY, pulley	1	

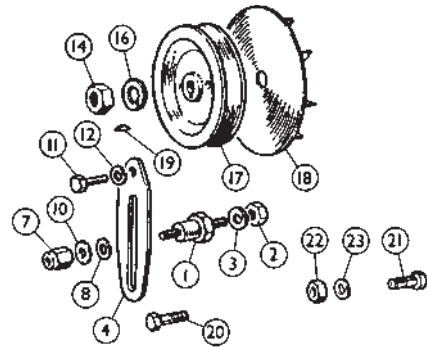

Dynamo Mountings, 100-6, 3000

1	031-404	NA	PILLAR, adjusting link	1	BN4, BN6, BN7, BT7, BJ7
	031-405	NA	PILLAR, adjusting link	1	BJ8
2	GHF203	€0.72	NUT, pillar to front plate	1	
3	GHF334	€1.32	WASHER, locking	1	
4	031-406	€17.28	ADJUSTING LINK	1	BN4, BN6, BN7, BT7, BJ7, BJ8 to (e)29K-H10271
	031-407	NA	ADJUSTING LINK	1	BJ8 from (e)29K-H10272
7	GHF223	€1.56	NUT, link to pillar	1	
8	GHF334	€1.32	WASHER, locking	1	
10	WP9	€2.04	WASHER, plain	1	
11	SH505071	€1.08	BOLT, link to dynamo	1	
12	GHF332	€0.84	WASHER, locking	1	
14	AJD8207Z	€2.16	NUT, plain, BSF	1	
	GHF223	€1.56	NUT, nyloc, UNF	1	
	NT607041	€1.80	NUT, jam, UNF	1	
16	GHF334	€1.32	WASHER, locking	1	BN4, BN6, BJ8
17	031-408	NA	PULLEY	1	BN4, BN6
	031-409	NA	PULLEY	1	BN7, BT7, BJ7
	031-410	NA	PULLEY	1	BJ8 to (e)29K-H10271
	031-304	€55.92	PULLEY	1	BJ8 from (e)29K-H10272
18	1B2178	NA	FAN	1	BN4, BN6, BN7, BT7, BJ7
	17D11	€19.92	FAN	1	BJ8
19	WKN405	€1.80	KEY, pulley	1	
20	BH605101	€2.16	BOLT, front, to side cover	1	
21	SH605091	€1.80	BOLT, rear, to side cover	1	
22	GHF201	€0.84	NUT	2	
23	GHF332	€0.84	WASHER, locking	2	

iii. Part Number Price €ea. Description Req. Details

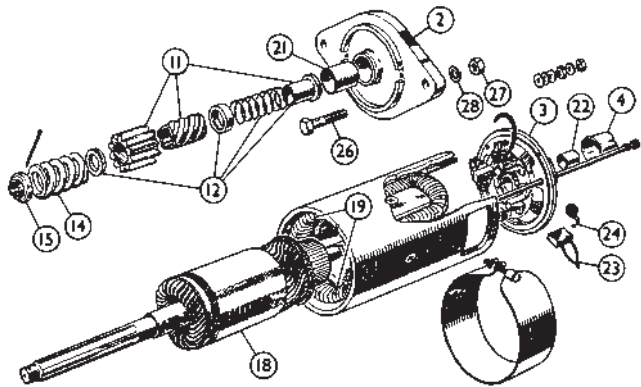

Starter

	NA	STARTER, exchange (25521B-D)	1	BN1, BN2, BN4, BN6 (This starter is unavailable. Use 13H837R as replacement)
13H837R	€177.48	STARTER, rebuilt (25578A-B) Modern pre-engaged type	1	BN7, BT7, BJ7, BJ8
	NA	CORE CHARGE for 540-410		
13H837X	€315.60	STARTER, gear reduction type	1	BN1-BJ8
2	503530	NA BRACKET, drive end	1	22521B-D
	NA	BRACKET, drive end	1	25578A-B
3	7H5498	NA BRACKET, commutator end	1	
4		NA CAP, shaft	1	
11	7H5008	NA PINION & SLEEVE	1	
12	070062	NA SPRING RETAINING KIT	1	
14	7H5007	€15.96 SPRING, pinion, main	1	
15	503527	€33.96 NUT	1	
18	163-000	NA ARMATURE	1	
19	7H5013	€106.56 FIELD COIL SET	1	
21	244714A	€5.64 BUSH, drive end	1	
22	242958A	€7.32 BUSH, commutator end	1	
23	GSB103	€8.16 BRUSH SET	1	
24	27H2291K	NA SPRING SET, brush tension	1	
26		NA BOLT, starter to block, BSF	2	BN1, BN2
	BH606151	€2.16 BOLT, starter to block, UNF	2	BN4 thru BJ8
27		NA NUT, BSF	2	BN1, BN2
	GHF202	€0.72 NUT, UNF	2	BN4 thru BJ8
28	GHF333	€0.72 WASHER, locking	2	

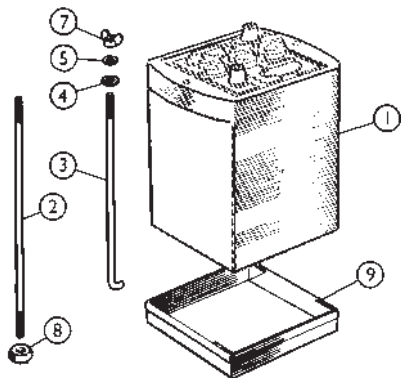

Batteries, 6 Volt

1	459-380	NA	BATTERY, 6-volt dry charged, rubber cased	2	original style, w "ears" BN1, BN2, BN6, BN7
	GBY3031D	€162.00	BATTERY, 6-volt dry charged, classic style	2	
2	807-015	€9.12	ROD, battery fixing, UNF	4	BN1, BN2
3		NA	ROD, battery fixing, UNF	4	BN6 to (c)8221
	NA	ROD, battery fixing, UNF	4	BN6 from (c)8222, BN7	
4	GHF300	€1.08	WASHER, plain	4	
5	GHF331	€0.84	WASHER, locking	4	
7	132068	€1.68	NUT, wing, UNF	4	
8		NA	NUT, lower	4	BN1, BN2
9	806-430	€242.40	TRAY & BRACKET KIT, battery (incl. nos. 2-9 plus top brackets for non-eared batteries)	1	
	NA	TRAY, battery		2	BN6, BN7

iii. Part Number Price €ea. Description Req. Details

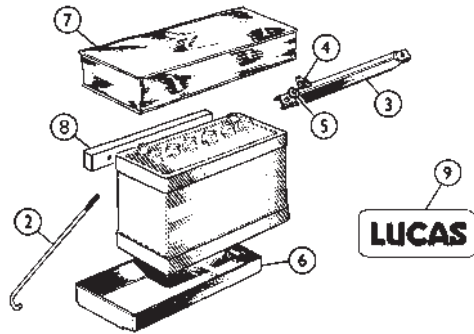

Battery, 12 Volt

1	GBY242D	€314.40	BATTERY, 12-volt dry charged	1	
2	14G5510	€7.44	ROD (J-BOLT), battery fixing	2	
3	601898	€9.72	BAR, battery fixing	1	
4	132068	€1.68	NUT, wing	2	
5	GHF301	€0.60	WASHER, plain	2	
6	14G1702	€35.64	TRAY, battery, plastic (original)	1	
	14G1702A	€73.56	TRAY, battery, steel (upgraded)	1	
7	14B8816	€15.48	COVER, battery, heat welded vinyl as original	1	
8	031-411	€22.32	BATTERY SUPPORT, wood, 3/4" thick	1	BN4-BJ8 to (b)76138
	031-423	€33.12	BATTERY SUPPORT, wood, 3" thick	1	BJ8 from (b)76139
9	CRST191	€6.12	BATTERY DECAL, Lucas	A/R	

Note: as originally built, all two seat cars used two six volt batteries, while four seat cars used one twelve volt battery.

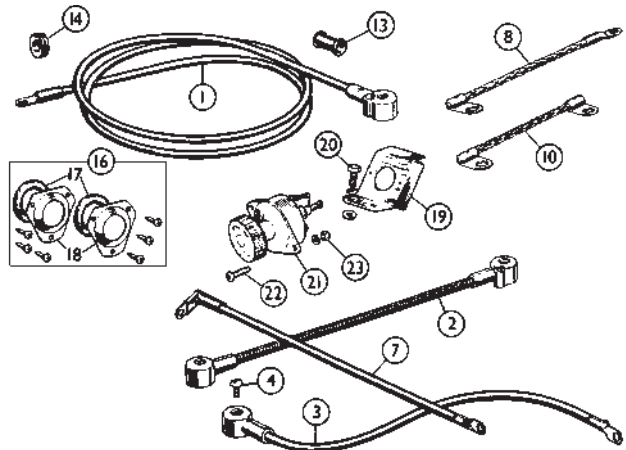

Battery Cables and Fittings

1	736-190	NA	CABLE, battery negative to solenoid	1	BN1, BN2, BN6, BN7
	736-200	NA	CABLE, battery negative to solenoid	1	BN4, BT7, BJ7, BJ8
2	736-130	NA	CABLE, battery link	1	BN1, BN2, BN6, BN7
3	736-140	€30.60	CABLE, battery positive to master switch	1	BN1, BN2
	5L734	NA	CABLE, battery positive to master switch	1	BN6, BN7
	736-180	€13.44	CABLE, battery positive to master switch	1	BN4, BT7, BJ7, BJ8
4	2K8645	€0.84	SCREW, for cap type terminals	2/4	
7	AHA6280	€25.56	CABLE, solenoid to starter	1	
8	736-230	NA	CABLE, battery master switch to ground	1	BN1, BN2
	736-240	NA	CABLE, batt. mstr. switch to ground	1	BN4 thru BJ8
	1B9078	€7.92	CABLE, batt. mstr. switch to ground, repl.	1	
10	2K6167	€27.72	CABLE, engine ground	1	
13	ACH8529	€5.28	SLEEVE, cable (rubber)	1	BN7 from (c)1065
14	3H822	€4.56	GROMMET, battery negative cable	1	BN4, BT7 to (c)15861
16	680-288	€24.72	GROMMET KIT, battery negative cable	1	
17	680-295	NA	GROMMET	2	BT7 from (c)15862, BJ7, BJ8
18		NA	CAP, grommet	2	
	NA	NA	SCREW	6	
19	031-412	€11.64	BRACKET, battery master switch	1	BN4, BT7, BJ7, BJ8
20	SH604041	€0.84	SCREW, bracket to body	2	
21	1B2804	€54.00	SWITCH, battery master	1	
22		NA	SCREW, master switch locating	2	
23	NH806011	€0.96	NUT	2	

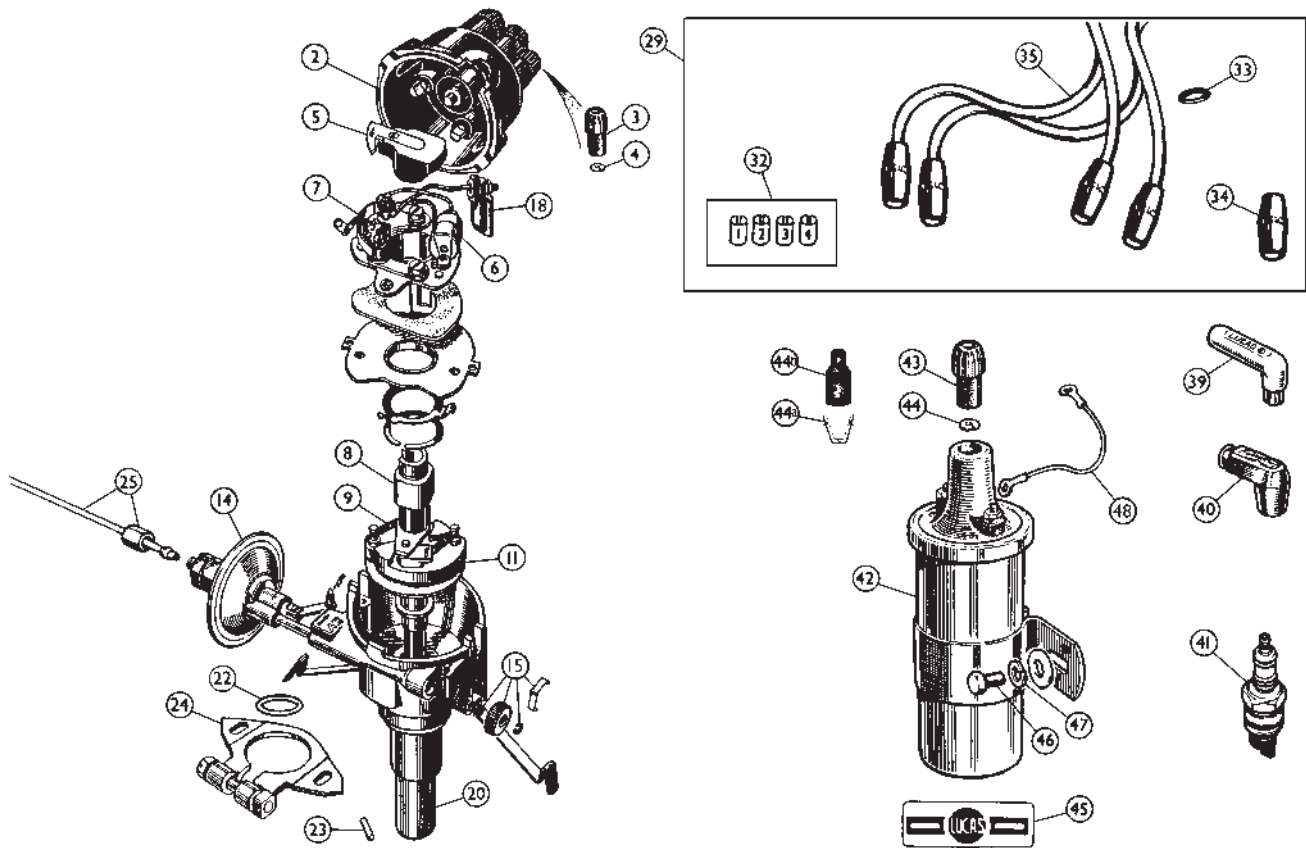

Part Number	Price €ea.	Description	Req.	Details
143-025	NA	DISTRIBUTOR ASSY (Lucas no. 40320)	1	BN1, BN2 to C.E.230360
11B479E	NA	DISTRIBUTOR ASSY (Lucas no. 40495)	1	BN2 from C.E.230361
143-045	NA	DISTRIBUTOR ASSY (Lucas no. 40422)	1	100M early
143-065	NA	DISTRIBUTOR ASSY (Lucas no. 40520)	1	100M late
2	€18.84	DISTRIBUTOR CAP	1	
3	€2.28	NUT, distributor cap	5	
4	€0.84	WASHER, terminal	5	
5	€14.40	ROTOR ARM, high quality (red)	1	
	€4.44	ROTOR ARM, Lucas	1	
	€6.12	ROTOR ARM, aftermarket	1	
6	€3.24	CONDENSER & LEAD, Lucas	1	
	€16.20	CONDENSER & LEAD	1	high quality aftermarket
7	€21.36	POINT SET, aftermarket	1	40320, 40422
	€9.96	POINT SET, Lucas	1	
	€15.96	POINT SET, Premium aftermarket	1	40495, 40520
	€5.28	POINT SET, aftermarket	1	
	€1.80	SCREW, for points	1	
	NA	SCREW, for condenser	1	
8	NA	CAM	1	
9	NA	SPRING SET	1	40320
	NA	SPRING SET	1	40495
	NA	SPRING SET	1	40422, 40520
	€31.80	SPRING SET, set of 5 assorted springs	1	
	NA	TOGGLE SET, spring	2	
11	NA	WEIGHT	2	
14	€114.24	VACUUM UNIT	1	40320
	€114.24	VACUUM UNIT	1	40495
	€114.24	VACUUM UNIT	1	100-M

Note: These new vacuum units are supplied with the original screw-on type union for the vacuum pipe.

Part Number	Price €ea.	Description	Req.	Details
29	€42.12	HT LEAD SET, also incl. #4, 44	1	with straight plug caps
32	€6.84	HT LEAD NUMBERING SET, 4 cylinder	1	
33	€1.44	O RING, cable, for no. 1 & 2 wires only	1	
34	€9.84	CAP, spark plug, Champion	4	straight cap
35	€5.40	HT LEAD SET, black	8	sold per meter
	€10.68	HT LEAD SET, yellow and black	8	
39	€11.64	CAP, spark plug	4	right angle caps period
40	€10.08	CAP, spark plug, "Champion"	4	alternatives
41	€8.40	SPARK PLUG, Champion (std.)	4	
	€4.32	SPARK PLUG, Champion (resistor)	4	BN1, BN2
	NA	SPARK PLUG, NGK	4	
	€4.92	SPARK PLUG, NGK (resistor)	4	
	€7.56	SPARK PLUG, Champion	4	100M
42	€26.64	IGNITION COIL, screw and spade terminals, push-in coil wire	1	replacement, period style
43	€2.52	NUT, coil wire terminal	1	for coils using screw-on
44	€0.84	WASHER, coil wire terminal	1	coil wires
42	€22.08	DECAL COIL, Lucas	1	spade terminals, push-in
	€37.44	SPORTS COIL, spade terminals, push-in coil wire	1	Intermotor brand
44a	€1.68	WIRE END, "push-in"	1	for replacement coils
44b	€1.80	BOOT	1	taking push-in wire
45	€3.36	LUCAS DECAL, for standard coils	1	
46	€2.40	BOLT, coil to block	2	
47	€0.84	WASHER, locking	2	
48	€1.80	LT WIRE, low tension (ring terminals)	1	

Ignition Wires and Coils

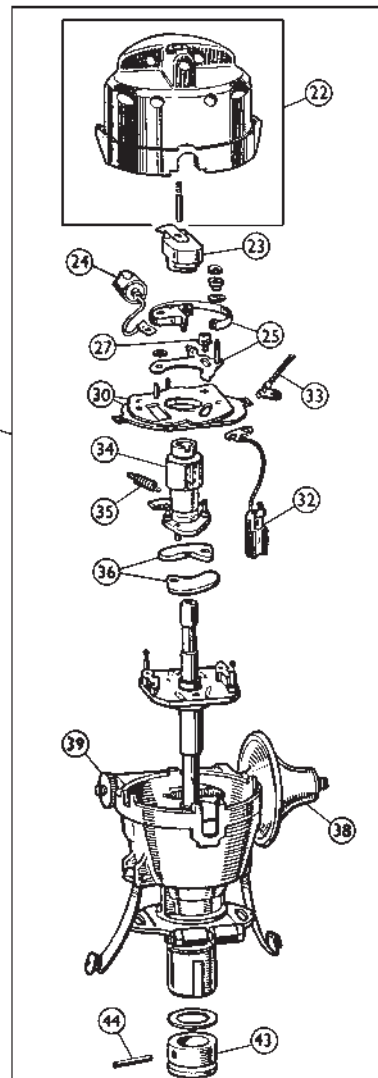
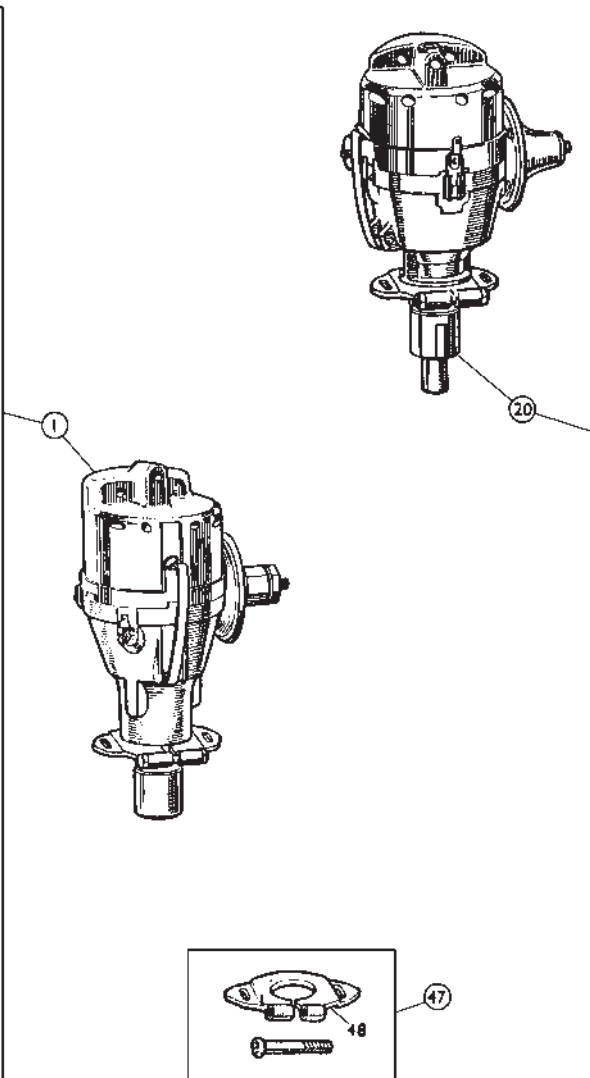
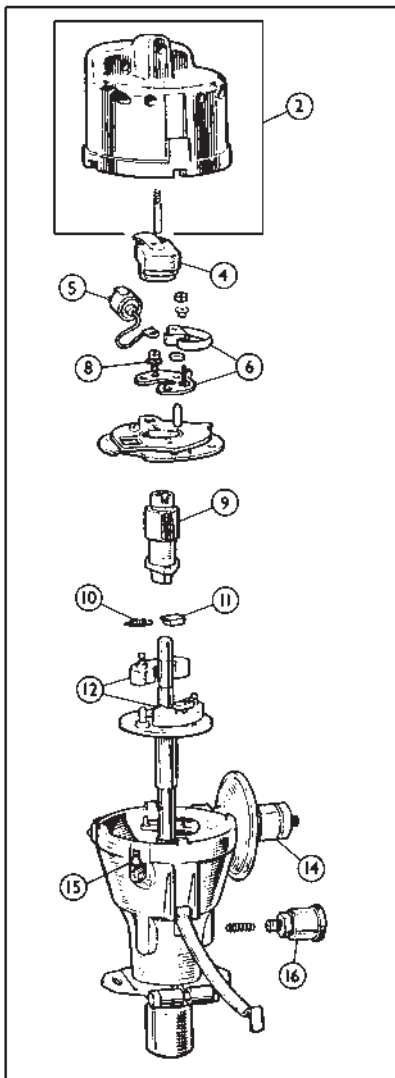

iii. Part Number Price €ea. Description

Req. Details

Ignition 100-6, 3000

BN4, BN6, BN7, BT7; BJ7 to (e)29F-H3562

Part Number	Price €ea.	Description	Req.	Details
1 142-965	NA	DISTRIBUTOR ASSEMBLY (Lucas no. 40532, model DM6)	1	BN4 to C.E.41606
143-015	NA	DISTRIBUTOR ASSEMBLY (Lucas no. 40581, model DM6)	1	BN4 from C.E.41607; BN6
143-050	NA	DISTRIBUTOR ASSEMBLY (Lucas no. 40662, model DM6)	1	BN7, BT7, BJ7 to (e)29F-H3562
2 GDC106	€41.64	DISTRIBUTOR CAP	1	
4 GRA102HQ	€14.40	ROTOR ARM, high quality (red)	1	
5 151-730	€3.24	CONDENSER & LEAD, Lucas	1	
GSC111HQ	€16.20	CONDENSER & LEAD	1	high quality aftermarket
6 GCS2102	€6.12	POINT SET, aftermarket	1	
GSC111	€5.28	CONDENSER & LEAD, aftermarket	1	
8	NA	SCREW, for points	1	
	NA	SCREW, for condenser	1	
9	NA	CAM	1	
10	NA	SPRING SET, auto advance	1	40532
	NA	SPRING SET, auto advance	1	40581, 40662
TT1903	€31.80	SPRING SET, auto advance (5 springs)	1	universal replacement
11	NA	TOGGLE SET, spring	2	
12	NA	WEIGHT	2	
14 17H5384	€123.12	VACUUM UNIT (with threaded vacuum line connector, as orig.)	1	
163-738	€17.04	ADJUSTER KIT, vacuum unit	1	
15	NA	CONNECTOR, Lucas (14 amp.)	1	40662
16	NA	LUBRICATOR	1	

iii. Part Number Price €ea. Description

Req. Details

BJ7 from (e)29F-H3563; BJ8

Part Number	Price €ea.	Description	Req.	Details
20 143-060	NA	DISTRIBUTOR ASSEMBLY, (Lucas no. 40920, model 25D6)	1	BJ7 from (E)29F-H3563
143-070	NA	DISTRIBUTOR ASSEMBLY, (Lucas no. 40966, model 25D6)	1	BJ8
22 GDC101	€35.64	DISTRIBUTOR CAP	1	
23 GRA102HQ	€14.40	ROTOR ARM, high quality (red)	1	
24 151-730	€3.24	CONDENSER & LEAD, Lucas	1	
GSC111	€5.28	CONDENSER & LEAD, aftermarket	1	
GSC111HQ	€16.20	CONDENSER & LEAD, premium aftermarket	1	
25 GCS2101	€5.28	POINT SET	1	
27 GCS1001S	€1.80	SCREW, for points	1	
	NA	SCREW, for condenser	1	
30 551-055	€51.12	BREAKER PLATE ASSY	1	
32 600329A	€12.24	LT LEAD & BUSH, Lucar terminal	1	
33 153-645	€8.16	DISTRIBUTOR BASE PLATE EARTH LEAD	1	
34	NA	CAM	1	
35 TT1903	€31.80	SPRING SET, auto advance (5 springs)	1	universal replacement
36 57H5420	NA	WEIGHT	2	
38 560-511	€114.24	VACUUM UNIT, threaded vac. line fitting	1	
560-512	€114.24	VACUUM UNIT, push-on vac. line fitting	1	(as fitted)
39 163-738	€17.04	ADJUSTER KIT	1	
42	NA	O RING	1	
43 513679A	€15.72	GEAR, driving distributor	1	BJ8 (40966)
44 057992	€1.20	PIN, driving dog retaining	1	
47 153-400	NA	PLATE, mounting, with screw & nut	1	replacement type
48 3H2138	€21.00	PLATE, mounting, without screw & nut	1	OE type
153-402	€7.68	BOLT & NUT for plate	1	

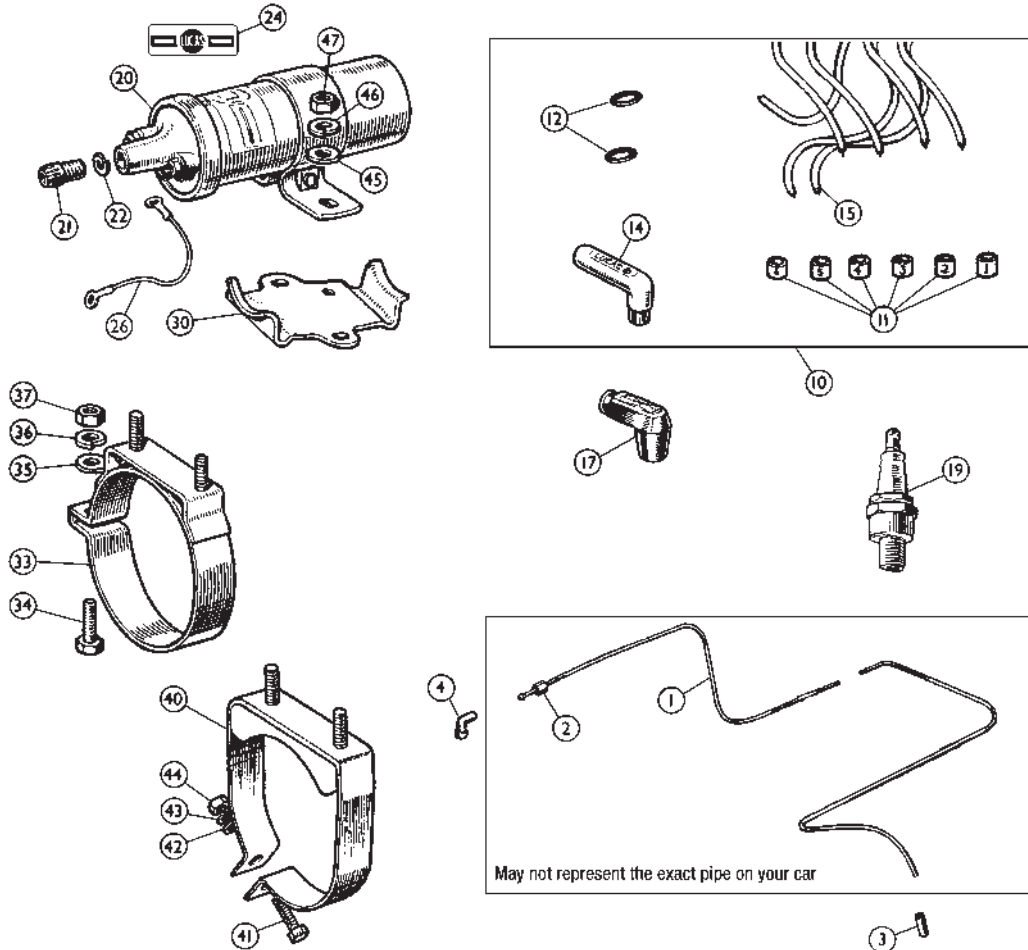

Part Number	Price €ea.	Description	Req.	Details
1	NA	VACUUM PIPE	1	BN4 to C.E.35895
	NA	VACUUM PIPE	1	BN4 from C.E.35896 to 48862
021-952	€27.72	VACUUM PIPE (fittings on both ends)	1	BN4 from C.E.48863, BN6, BN7 & BT7 to (e)29D-H26212
163-575	€24.48	VACUUM PIPE	1	BN7, BT7 from (e)29E-H10, BJ8
163-595	€17.16	VACUUM PIPE	1	BJ8
2	€6.72	NUT	A/R	
3	€3.36	CONNECTION, carburettor end, rubber	1	BN7 & BT7 from (e)29E-H101, BJ7, BJ7
4	€3.24	CONNECTION, distributor end	1	BJ8

Ignition Wires and Coils

10	021-753	€61.32	HT LEAD SET	1	period style	
11	171-640	€18.72	SLEEVE SET, wire numbering	1		
12	C9928A	€1.44	RING, cable, for nos. 1 & 2, 5 & 6 only	2		
14	3H1422	€11.64	CAP, spark plug	6	period style alternative	
15	AAA5981M	€5.40	HT LEAD SET, black	7	sold per meter	
	TT2982M	€10.68	HT LEAD SET, yellow and black	7		
17	WCX600	€10.08	CAP, spark plug, 'Champion'	6	period style replacement	
19	N5C	€8.40	SPARK PLUG, Champion	6	BN4, BN6, BN7, BT7	
	152-121	€4.32	SPARK PLUG, Champion*	6		
	175-080	NA	SPARK PLUG, NGK	6		
	175-081	€4.92	SPARK PLUG, NGK*	6		
	N12YCC	€8.76	SPARK PLUG, Champion	6		BJ7, BJ8
	GSP4482	€5.76	SPARK PLUG, Champion*	6		

*These are resistor type spark plugs.

20	GCL101	€26.64	COIL, ignition, screw terminals	1	screw-in coil wire
21	105036	€2.52	NUT, coil wire	1	
22	214279A	€0.84	WASHER, coil wire	1	push-in coil wire, spade
20	GCL110	€22.08	COIL, ignition, Lucas	1	
	TT2981	€37.44	SPORTS COIL, "Intermotor" brand	1	
24	CRST156	€3.36	LUCAS DECAL, for standard coils	1	
26	509347	€1.80	WIRE, low tension, ring terminals	1	BN4, BN6, BN7, BT7, BJ7 to (e)29F-H3562

Part Number	Price €ea.	Description	Req.	Details	
125957	€1.08	WIRE, low tension, Lucas terminals	1	BN7, BT7, BJ7 to (e)29F-H3562	
30	11G221	€35.16	PLATE, steady, coil	1	
33	473-095	NA	BRACKET, coil to dynamo	1	
34	GHF101	€0.72	BOLT, bracket clamping	1	BN4, BN6, BN7, BT7
35	WM57	€1.20	WASHER, plain	3	BJ8
36	GHF331	€0.84	WASHER, locking	3	
37	GHF200	€0.96	NUT	3	
40	473-135	€48.12	BRACKET, coil to dynamo	1	
41	NA		BOLT, bracket clamping	1	
42	WM57	€1.20	WASHER, plain	1	
43	GHF331	€0.84	WASHER, locking	1	
44	GHF200	€0.96	NUT	1	
45	PWZ205	€0.72	WASHER, plain	2	
46	GHF332	€0.84	WASHER, locking	2	
47	GHF201	€0.84	NUT	2	

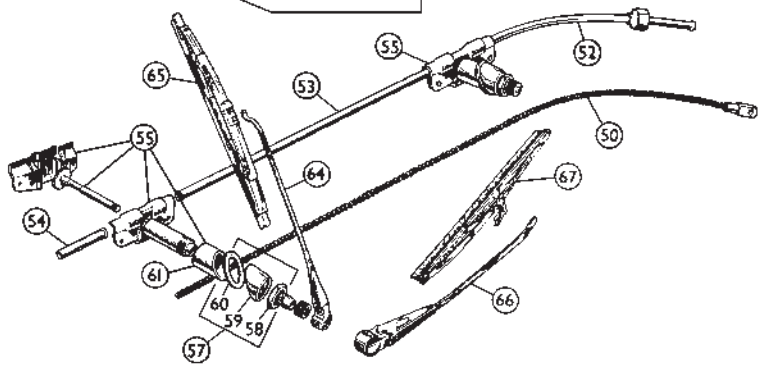
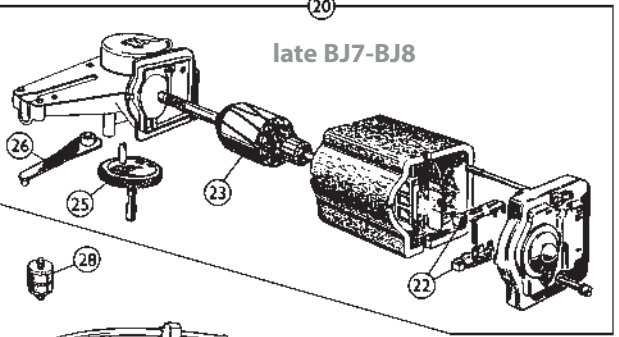
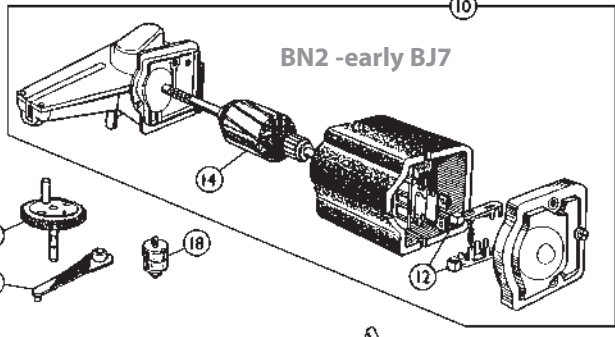
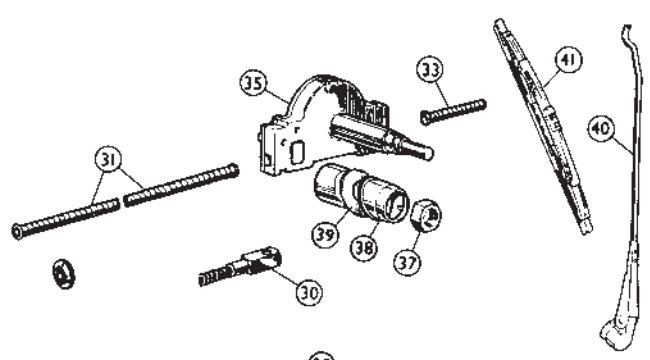
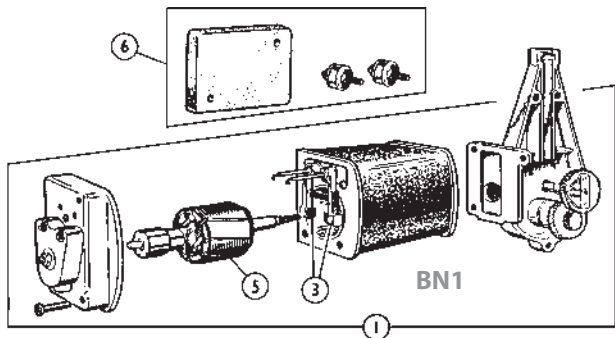

ill. Part Number Price €ea. Description Req. Details

Wiper Motor: BN1

1	501684R	€322.80	WIPER MOTOR (Lucas no. 75150A)	1	reconditioned
	554-010	NA	BRUSH GEAR	1	
3	508170	€12.48	BRUSH SET (carbon blocks only)	1	
		NA	SPRING SET, brush	1	
5	554-000	NA	ARMATURE	1	
6	501684FK	NA	MOUNTING KIT	1	
			(inc. 2 studs, 2 nuts, 2 washers, 2 rubber grommets & 1 rubber pad)		

Wiper Motors: BN2, BN4, BN6, BN7, BT7; BJ7 to (b)60791

10	568-010	NA	WIPER MOTOR (Lucas nos. 75214A, 75297B-F)	1	alternative to 568-020
	568-020	NA	WIPER MOTOR (Lucas nos. 75298A-H)	1	alternative to 568-010
	508170	€12.48	BRUSH GEAR	1	
12	508170	€12.48	BRUSH SET (carbon blocks only)	1	
		NA	SPRING SET, brush	1	
		NA	FIELD COIL	1	screw terminal; 75214A, 75297B-E, 75298A-F
		NA	FIELD COIL	1	Lucar terminal; 75297F, 75298H
14	17H5255	NA	ARMATURE	1	
15		NA	SHAFT & GEAR	1	75214A, 75297A-D, 75298A-E
		NA	SHAFT & GEAR	1	75297E-F, 75298F-H
16		NA	CONNECTING LINK	1	
18	17H5431	€12.96	BUSH & PIN SET, wiper motor mounting	3	

Wiper Motor: BJ7 from (b)60792; BJ8

20	568-028	NA	WIPER MOTOR (Lucas no. 75456)	1	
22	508170	€12.48	BRUSH ASSEMBLY	1	
	508170	€12.48	BRUSH PAIR (carbon blocks only)	1	
		NA	SPRING SET, brush	1	
		NA	FIELD COIL	1	
		NA	ARMATURE	1	
23		€93.12	GEAR, wiper motor	1	
25	511007	NA	CONNECTING LINK	1	
26		NA	CONNECTING LINK	1	
28	17H5431	€12.96	BUSH & PIN SET, wiper motor mounting	3	
	17H5431X	NA	GROMMET, wiper motor mounting	3	

ill. Part Number Price €ea. Description Req. Details

Wiper System: BN1

30	501730	€43.32	RACK, wheel box driving	1	cut to 30-5/8"
31		NA	CASING, outer, motor to wheelbox	1	
		NA	CASING, outer, wheelbox to wheelbox	1	
33		NA	CASING, offside wheelbox, 3"	1	
35		NA	WHEELBOX	2	
37	502005NT	€11.64	NUT, chrome	2	
38	568-065	€43.68	BEZEL, chrome	2	
39		NA	WASHER, rubber	2	
40	107965	€32.76	WIPER ARM, LHD	2	
		NA	WIPER ARM, RHD	2	
41	GWB145Z	€17.16	BLADE, wiper	2	

Wiper System: BN2, BN4, BN6, BN7, BT7, BJ7, BJ8

50	RTC202A	€18.00	RACK, wheel box driving	1	cut to 31-13/32"
52		NA	CASING, outer, motor to wheelbox	1	BN2, BN4, BN6, BN7, BT7, BJ7 to (b)60791
		NA	CASING, outer, motor to wheelbox	1	
		NA	CASING, outer, wheelbox to wheelbox	1	BJ7 from (b)60792; BJ8
53		NA	CASING, outer, wheelbox to wheelbox	1	
54	575047A	€7.56	CASING, outer, wheelbox extension	1	
	AAU1909A	€28.44	CASING, outer (will make #52, 53 or 54) 1 (cut and swage to fit)	1	
55	37H6316	€51.12	WHEELBOX	2	BN2 thru BJ8
57	37H6316FK	€15.48	BEZEL KIT	2	
58	ANK3459	€2.88	NUT, chrome	2	
59	ADB826	€6.60	BEZEL, chrome	2	
60	ADC560	€1.08	WASHER, rubber	2	
61		NA	BUSH, rear (included with #55)	2	
64	114488	€29.76	WIPER ARM, LHD	2	BN2, BN4, BN6, BN7, BT7
	114485	€29.76	WIPER ARM, RHD	2	
65	GWB145Z	€17.16	BLADE, wiper, repro., 9"	2	
	164-977	€4.32	REFILL, wiper blade	2	
			(Refill is rubber only - does not include metal strip.)		
66	BHA4396	€29.52	WIPER ARM, LHD	2	
	37H4952	€26.16	WIPER ARM, RHD	2	BJ7, BJ8
67	GWB219Z	€9.00	BLADE, wiper	2	

iii. Part Number Price €ea. Description Req. Details

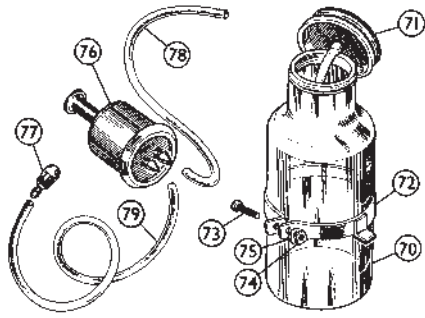

Windscreen Washers: BN4 to C.E.68959; BN6 to (c)1182

70	NA	WASHER BOTTLE, glass	1
	NA	WASHER BOTTLE, plastic alternative	1
71	NA	CAP & TUBE ASSEMBLY	1
72	NA	BRACKET, washer bottle	1
73	NA	SCREW, bracket to washer bottle	1
74	NA	NUT	1
75	NA	WASHER, plain	2
76	NA	PUMP ASSEMBLY	1
77	NA	JET ASSEMBLY, twin outlet	1
78	NA	TUBE, suction, rubber	1
79	NA	TUBE, delivery, rubber	1

iii. Part Number Price €ea. Description Req. Details

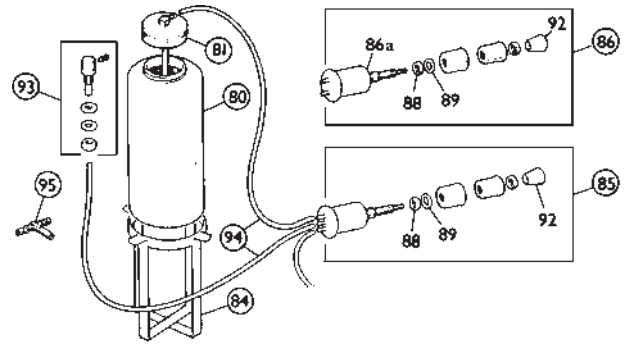

Windscreen Washers: BN4 from C.E.68960; BN6 from (c)1183; BN7, BT7, BJ7

80	361-115	NA	WASHER BOTTLE, small neck, 1-1/2" dia.	1] alternative
81		NA	CAP & TUBE ASSEMBLY, 1-1/2" dia.	1	
	37H729	€33.96	WASHER BOTTLE, large neck, 2" dia.	1] alternative
	AHH6848		CAP & TUBE ASSY, 2" dia.	1	
84	565-005	€48.12	BRACKET, washer bottle	1	
85	27H9624	€88.92	PUMP ASSEMBLY (1 inlet, 2 outlets)	1] BN4 from C.E.68960; BN6, BN7, BT7, BJ7 to (c)20125
86	565-065		PUMP ASSEMBLY, 1 inlet, 1 outlet	1	
86a	17H2672		WASHER PUMP, manual	1] BJ7 from (c)20126
87	GWW404	€2.88	CONNECTION, 3-way	1	
88			NUT	2	
89	GHF323	€0.96	WASHER, shakeproof	1	
92	27H9625	€9.84	KNOB	1	
93	GWW802	€5.64	JET ASSEMBLY, single outlet	2	
94	GWW201M	€1.92	TUBING, 1/8" ID	A/R] sold per meter
	GWW202M	€3.00	TUBING, 3/16" ID	A/R	

Note: The length required varies from car to car. Please measure carefully the length you need.

95	GWW404	€2.88	CONNECTION, 3-way	1	BJ7 from (c)20126
----	--------	-------	-------------------	---	-------------------

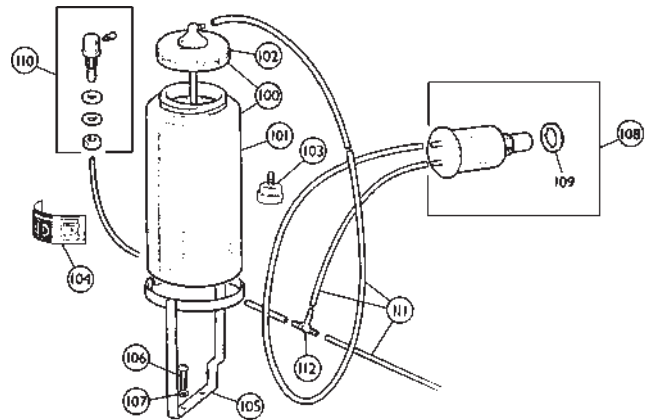

Windscreen Washers: BJ8

100	GWW918K	€18.36	WASHER BOTTLE KIT (includes washer bottle, cap, label, pick-up tube & valve)	1	
101	GWW918		WASHER BOTTLE	1	
102	AHH6848		CAP & TUBE ASSEMBLY	1	
103	GWW506	€3.48	NON-RETURN VALVE	1	
104	CRST124	€3.48	LABEL, Tudor	1	
105	13H232	€9.72	BRACKET, washer bottle	1	
106	PMZ308	€0.72	SCREW, bracket	2	
107	GHF331	€0.84	WASHER, locking	2	
108	GWW102	€26.88	WASHER PUMP, manual	1	
	GWW102B		WASHER PUMP, manual, plastic	1	
109			RING, locking	1	
110	GWW802	€5.64	JET ASSEMBLY, single outlet	2	
111	GWW202M	€3.00	TUBING, 3/16" ID	A/R] sold per meter
	GWW201M	€1.92	TUBING, 1/8" ID	A/R	
112	GWW404	€2.88	CONNECTION, 3-way	1	

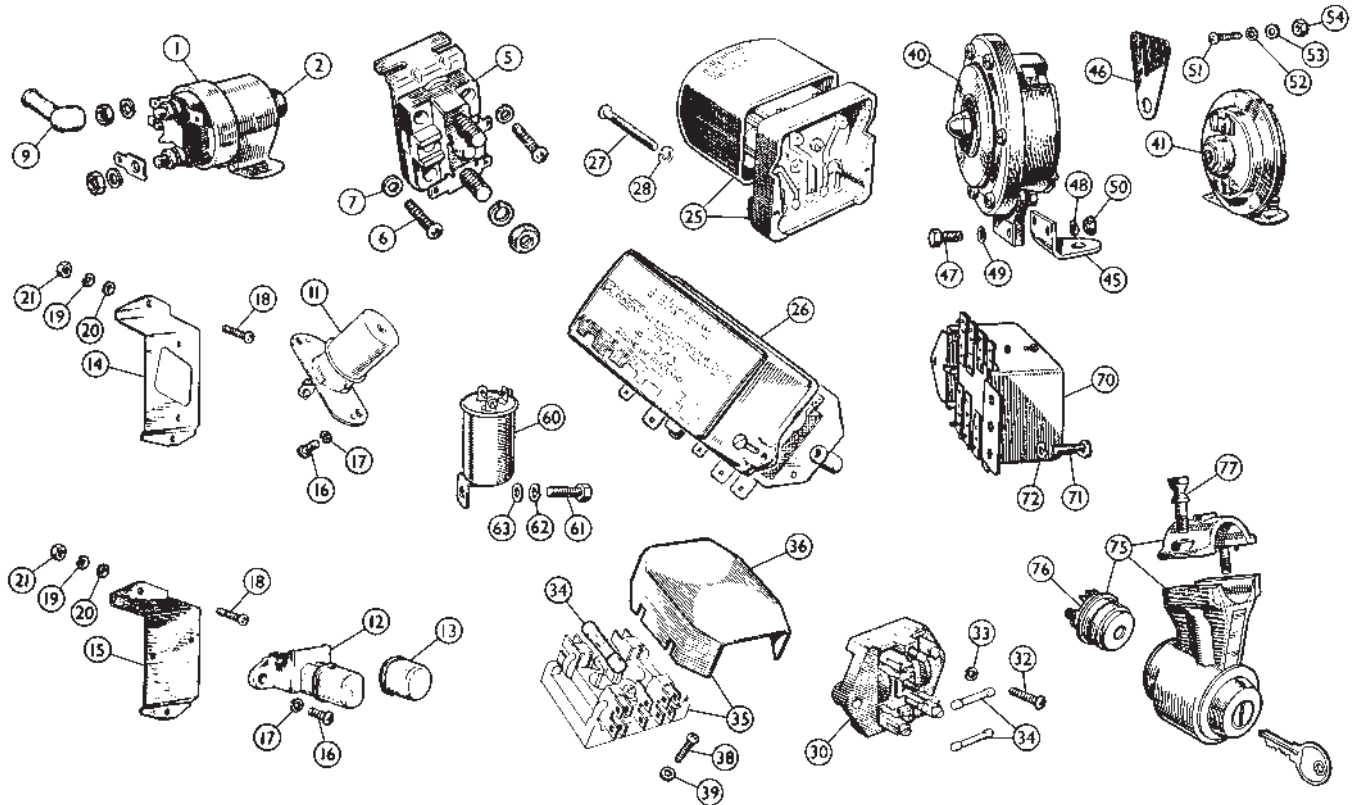

iii. Part Number Price €ea. Description Req. Details

Switches, Fuses and Regulators

Starter Solenoid

1	BCA4501	€46.20	SOLENOID, starter	1	excellent repro.
2	27H5576	€4.92	CAP, rubber	1	
5	546-151	NA	SOLENOID, starter, Lucas	1	alternative to 546-020
	BMK1727	€13.80	SOLENOID, starter, reproduction	1	
6	PMZ308	€0.72	SCREW, solenoid to body	2	
7	GHF331	€0.84	WASHER, locking	2	
9	8G548	€2.40	BOOT, terminal insulating	2	

Headlamp Dip Switches

	NA		SWITCH, headlamp dip	1	BN1 (not avail. use 140-900)
11	11G2007	€49.32	SWITCH, headlamp dip	1	BN2 thru BJ7
12	LU34790	€21.60	SWITCH, headlamp dip	1	BJ8
13	RTC432CAP	NA	RUBBER CAP	1	
14	542-145	€28.68	BRACKET, dipper switch	1	BN4 thru BJ7
15	542-155	€23.40	BRACKET, dipper switch	1	BJ8
16	PMZ306	€1.08	SCREW, switch to bracket	1	BN1 thru BJ7
	PMZ308	€0.72	SCREW, switch to bracket	2	BJ8
17	GHF331	€0.84	WASHER, locking	2	
18	SE604051	€0.84	SCREW, bracket to body	2	
19	GHF331	€0.84	WASHER, locking	2	
20	GHF300	€1.08	WASHER, plain	2	
21	GHF200	€0.96	NUT	2	

Voltage Regulators

25	142-003	€98.16	VOLTAGE REGULATOR (cleaned, tested & adjusted)	1	BN1 thru BJ7
	3H1835	€63.84	VOLTAGE REGULATOR	1	(requires cleaning & adjustment)
	142-005	€1.44	SCREW, wire retaining	5	
26	GEU6607	€48.48	VOLTAGE REGULATOR	1	BJ8
27	PMZ320	€1.20	SCREW, control box to bulkhead	2/3	qty. increases on BJ8
28	GHF331	€0.84	WASHER, locking	2/3	

Fuse Boxes

30	1G2613	€31.08	FUSE BOX, screw terminals	1	
32	PMZ307	€1.20	SCREW, fuse box to bulkhead	2	BN1 thru BJ7
33	GHF331	€0.84	WASHER, locking	2	
34	GFS35X	€1.08	FUSE, 35 amp.	2	
	GFS50X	€0.96	FUSE, 50 amp.	2	
35	606253A	€18.48	FUSE BOX, Lucar terminals	1	
36	505158A	€6.96	COVER	1	BJ8
38	SE910201	€1.08	SCREW, fuse box to bulkhead	1	
39	GHF331	€0.84	WASHER, locking	1	

iii. Part Number Price €ea. Description Req. Details

Horns

40	NA		HORN, low note, 'Altette'	1	
	NA		HORN, high note, 'Altette'	1	
41	BHA4514	€61.92	HORN, low note	1	
	BHA4515	€61.92	HORN, high note	1	
45	NA		PLATE, tapped, horn to crossmember	2	Altette horns
46	57H5309	€4.08	BRACKET, horn mounting	2	
47	GHF117	€0.72	BOLT, horn and bracket mounting	4/6	horns mounted on crossmember
48	GHF331	€0.84	WASHER, locking	4/6	
49	GHF300	€1.08	WASHER, plain	4/6	
50	GHF200	€0.96	NUT	4/6	
51	SE604041	€0.84	SCREW, horn and bracket mounting	4	horns mounted on hood aperture support channel
52	GHF331	€0.84	WASHER, locking	4	
53	GHF301	€0.60	WASHER, plain	4	
54	GHF200	€0.96	NUT	4	

Flasher Units

60	GFU2101	€11.04	FLASHER UNIT	1	screw terminals
	GFU2103	€14.40	FLASHER UNIT	1	Lucar terminals
61	SE604041	€0.84	SCREW, flasher unit to bulkhead	1	
62	GHF331	€0.84	WASHER, locking	1	BN1 thru BJ7
63	GHF300	€1.08	WASHER, plain	1	
	PMZ308	€0.72	SCREW, flasher unit to bulkhead	1	
	GHF331	€0.84	WASHER, locking	1	BJ8
	NA		WASHER, plain	1	
70	3H1454	€102.24	FLASHER RELAY, upgraded repro	1	
71	PMZ308	€0.72	SCREW, relay to wheelarch	3	
72	GHF331	€0.84	WASHER, locking	3	

Steering Lock/Ignition Switch

75	NA		LOCK ASSEMBLY, steering column	1	rare option: BN7, BT7, BJ7, BJ8
76	NA		SWITCH, ignition	1	
77	51K4001	€7.44	BOLT, shear	2	

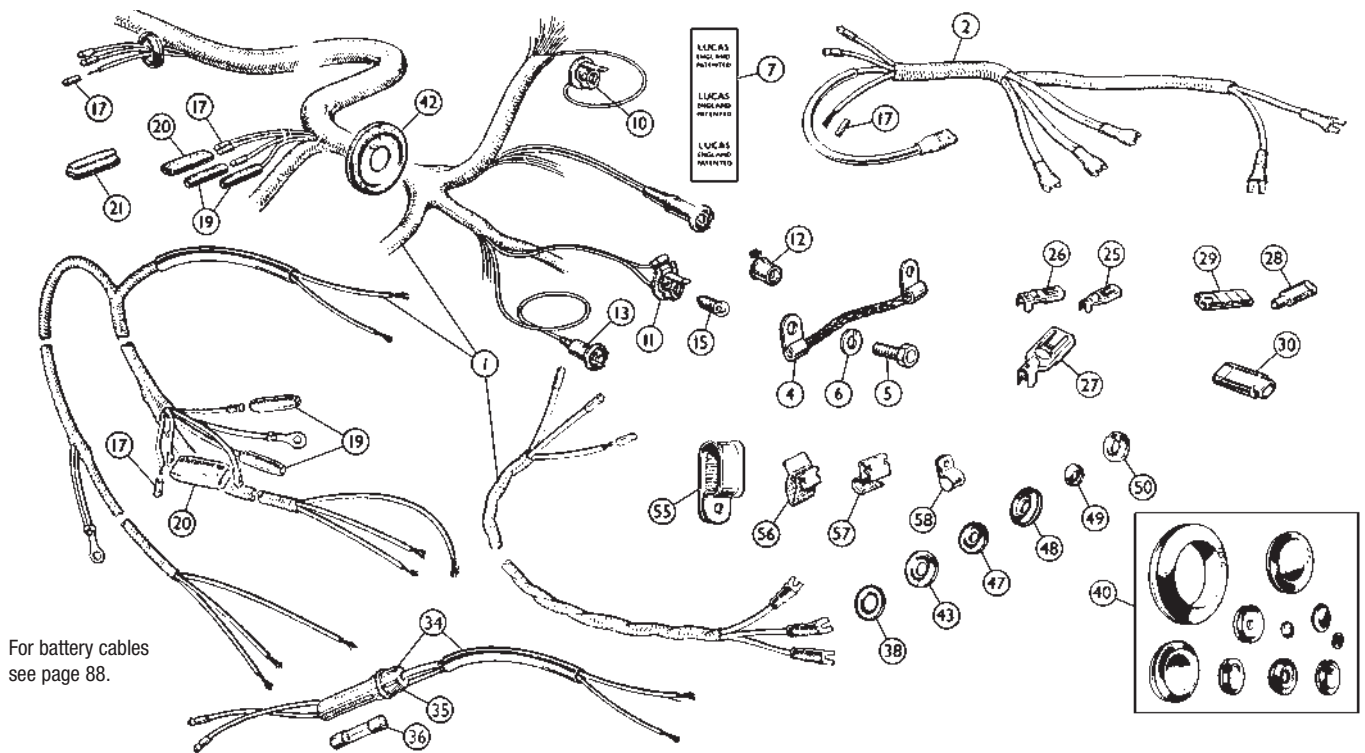

For battery cables see page 88.

Part Number	Price €ea.	Description	Req.	Details
Wiring & Fittings				
Moss wiring harnesses are complete except for battery and ignition cables, O/D sub harness, headlamp pigtails, and steering column wires. We offer lacquer braided wire as originally fitted to pre-BJ7s, or more economical PVC covered wire for all applications. Both types are bound by cotton braiding as original, and are color coded as original.				
New harnesses may have some non-original dash lamp sockets. These use wedge-base bulbs below.				
GLB504	€2.04	BULB, wedge base, 3 watt	A/R	} new wiring harnesses
GLB501	€1.44	BULB, wedge base, 5 watt	A/R	
1 ML691	€396.00	WIRING HARNESS, cloth/pvc	1	} BN1
357-170	€409.20	WIRING HARNESS, cloth/braid	1	
356-320	€331.20	WIRING HARNESS, cloth/pvc	1	} BN2
357-180	€403.20	WIRING HARNESS, cloth/braid	1	
MM356-330	€369.60	WIRING HARNESS, cloth/pvc	1	} BN4 to C.E.68959, BN6 to (c)3459
357-185	€459.60	WIRING HARNESS, cloth/braid	1	
MM356-340	€369.60	WIRING HARNESS, cloth/pvc*	1	} BN4 from C.E.68960, BN6 from (c)3460, BN7, BT7, BJ7
Does not include auto choke wiring for BN7 & BT7 from (e) 29D-H2864 - 6394.				
357-190	€501.60	WIRING HARNESS, cloth/braid*	1	} BJ8 to (b)76137 (Mar '65)
AHB6413	€405.60	WIRING HARNESS, cloth/pvc	1	
*Lacquer braid changed to pvc wiring gradually during BN7/BT7 production.				
MM356-355	€368.40	WIRING HARNESS, cloth/pvc	1	} BJ8 from (b)76138
356-375	€19.80	SUB-HARNESS, number plate lights (includes inline fuse)	1	
2 356-395	€43.20	OVERDRIVE HARNESS	1	} BN1
356-425	€47.76	OVERDRIVE HARNESS, with screw type terminals	1	
356-415	€38.64	OVERDRIVE HARNESS, braid wrap with push-on type terminals	1	} early BJ8
356-420	€28.08	OVERDRIVE HARNESS, vinyl wrap	1	
4 2K6167	€27.72	CABLE, engine ground	1	} late BJ8
5	NA	SCREW, cable to frame	1	
6 GHF333	€0.72	WASHER, locking	1	} late BJ8
7 CRST122	€5.28	LABEL, wiring ties, Lucas 1x strip	1	
10 070066	€13.80	BULBHOLDER, single cable, self grounding, screw in bulb	A/R	} replacement type
11 502342	€13.32	BULBHOLDER, twin cable, separate ground, screw in bulb	A/R	
12 13H1927	€8.76	BULBHOLDER, twin cable, separate ground	A/R	} replacement type
13 13H1924	€6.60	BULBHOLDER, single cable, self grounding, screw in bulb	A/R	
15 GLB987	€1.20	BULB, screw in type	A/R	} replacement type
GLB504	€2.04	BULB, push-in, for 13H1927	A/R	
17 003632	€1.08	WIRE TIP, solder type	A/R	} brass with tinned finish lamp ground wires
27H6713	€2.76	WIRE TIP, solderless type	A/R	
19 104618	€0.96	CONNECTOR, single line	A/R	} replacement type
20 RTC603A	€1.32	CONNECTOR, double line	A/R	
21 2H4992	€11.76	CONNECTOR, triple line	A/R	} replacement type
25 161-510	€0.96	CONNECTOR, Lucar, 3/16" wide	A/R	

Part Number	Price €ea.	Description	Req.	Details
26 RTC220A	€1.20	CONNECTOR, Lucar, 1/4" wide	A/R	} replacement type
27 47H5419	€1.44	CONNECTOR, Lucar, 3/8" wide	A/R	
28 BMK449	NA	SLEEVE, 3/16" Lucar connector	A/R	} replacement type
29 511269	€1.32	SLEEVE, 1/4" Lucar connector	A/R	
30 515399	€1.08	SLEEVE, 3/8" Lucar connector	A/R	} replacement type
34 356-375	€19.80	HARNESS, license lamp	1	
35 UKC4446	€3.24	HOLDER, fuse (in-line)	1	} late BJ8
36 GFS10X	€1.08	FUSE, 10 amp	1	
38 C9928A	€1.44	O RING, side lamp cables, rubber	A/R	} (general assortment)
40 681-018	€22.08	GROMMET & PLUG KIT, firewall	1	
GAC4120X	€17.04	GROMMET KIT, body	1	} (general assortment)
ACB8474	€2.76	GROMMET, for 5/8" hole, 3/8" ID	1	
42 682-195	€3.72	GROMMET, for 1-3/8" hole, 1/2" ID	1	} BN1, BN2, BN4 to (C)500
2H2065	€6.12	GROMMET, for 1-3/4" hole, 1/2" ID	1	
43	NA	GROMMET, dip switch harness	2	} BN1, BN2
	NA	GROMMET, stator tube cable through front apron	1	
	NA	GROMMET, flasher cable through bulkhead	1	} BN1, BN2
	NA	GROMMET, chassis harness through bulkhead & boot panel	2	
47	NA	GROMMET, chassis harness through wiring plate on bulkhead	1	} BJ7, BJ8
48 ACB8474	€2.76	GROMMET, chassis harness	1	
49 RFN403	€1.80	GROMMET, tank unit cable through boot vertical panel	1	} BN4 thru BJ8
50	NA	GROMMET, number plate lamp, cable through rear panel	1	
55	NA	CLIP, main harness to bulkhead	2	} BN1, BN2
162-345	€2.16	CLIP, main harness to bulkhead	1	
56 11K9181	€1.20	CLIP, h/lamp cable to wing well	2	} BN4 thru BJ8
57	NA	CLIP, stator tube cable to crossbrace	1	
58 PCR311	€2.40	'P' CLIP, 3/16" cable dia. x 11/32" hole dia.	A/R	} BN7, BT7, BJ7, BJ8
PCR407	€1.92	'P' CLIP, 1/4" cable dia. x 7/32" hole dia.	A/R	
CP105081	€1.92	'P' CLIP, 5/16" cable dia. x 7/32" hole dia.	A/R	} BN7, BT7, BJ7, BJ8
PCR509	€1.92	'P' CLIP, 5/16" cable dia. x 9/32" hole dia.	A/R	
PCR607	€2.52	'P' CLIP, 3/8" cable dia. x 7/32" hole dia.	A/R	} BN7, BT7, BJ7, BJ8
162-260	NA	'P' CLIP, 7/16" cable dia. x 7/32" hole dia.	A/R	
PCR807	€2.04	'P' CLIP, 1/2" cable dia. x 7/32" hole dia.	A/R	} BN7, BT7, BJ7, BJ8
PCR809	€1.92	'P' CLIP, 1/2" cable dia. x 9/32" hole dia.	A/R	
PCR1007	€1.92	'P' CLIP, 5/8" cable dia. x 7/32" hole dia.	A/R	} BN7, BT7, BJ7, BJ8
162-270	€2.16	'P' CLIP, 9/16" cable dia. x 7/32" hole dia.	A/R	

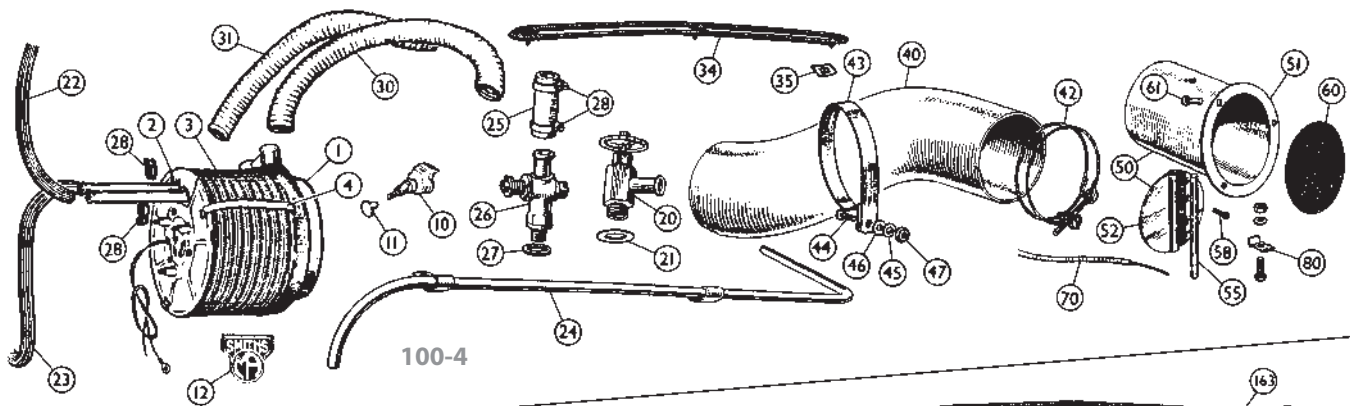

100-4

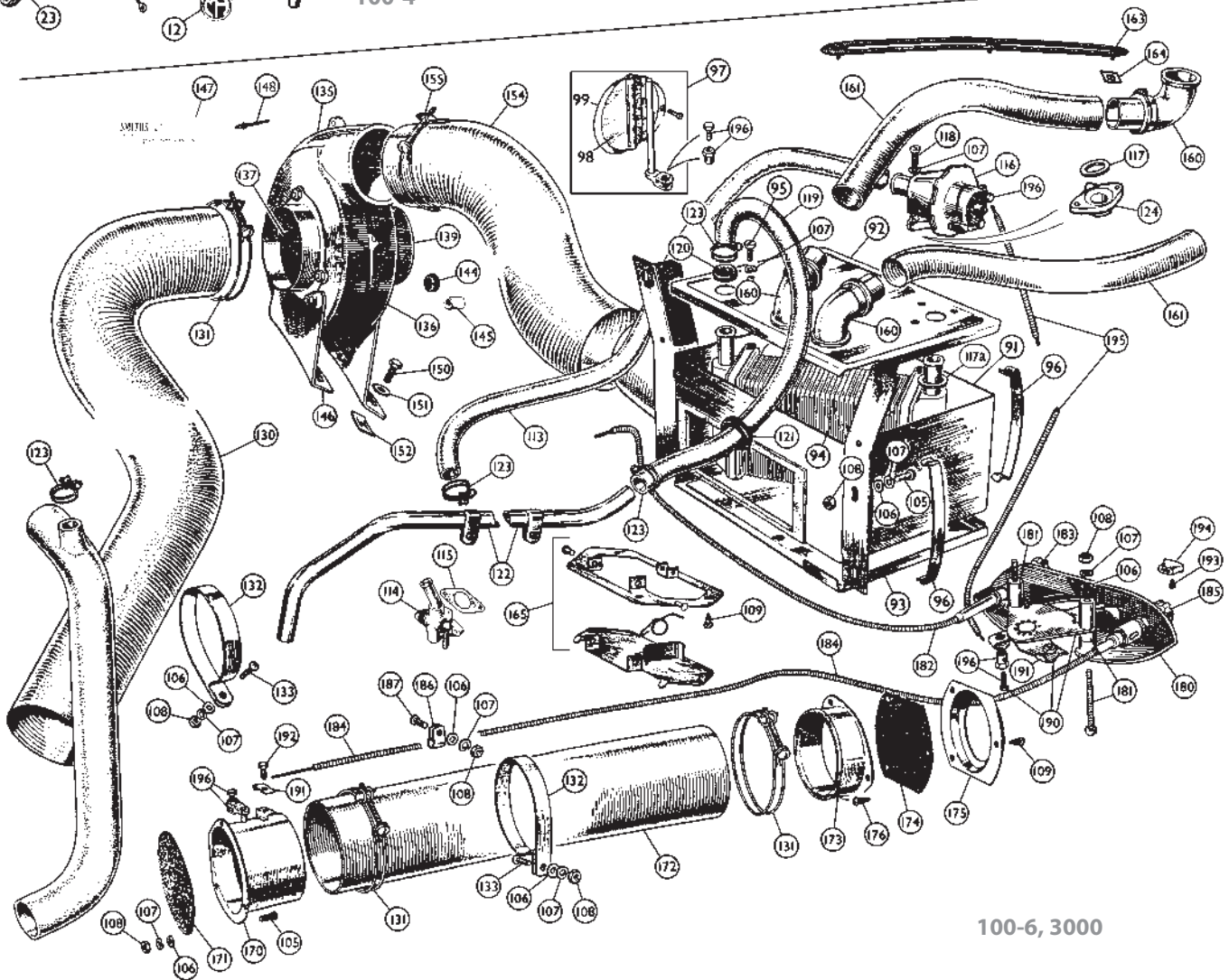

100-6, 3000

ill.	Part Number	Price €ea.	Description	Req.	Details
100-4 Heater Assembly					
1	NA		HEATER ASSEMBLY	1	
2	NA		BODY, heater	1	
3	700899M/4	€633.60	MATRIX, heater, 4 deep	1	
4	363-026	€15.84	CLIP	3	
	NA		MOTOR ASSEMBLY	1	
	NA		FAN	1	
8	NA		GROMMET, pipes through bulkhead	2	
10	NA		SWITCH, rheostat	1	
11	500513	€8.64	KNOB, screw retained	1	original type
	500513S	NA	SCREW, knob	1	
	57H5260	€91.44	SWITCH, rheostat	1	replacement type
	509735	€6.72	KNOB, push-on	1	
12	408-351	€10.20	STICKER, "Smiths" logo	1	above knob on heater

Water Pipes and Control Valves

20	88G588	€23.16	TAP, on cylinder head, water control	1	
21	AAA836	€1.56	WASHER, valve to head	A/R	
22	NA		HOSE, valve to heater inlet	1	
23	NA		HOSE, heater outlet to return pipe	1	
24	021-908	€59.52	RETURN PIPE, copper	1	
25	682-050	NA	HOSE, return pipe to heater tap	1	
26	3H641	€121.80	HEATER TAP, on water pump	1	
27	324-485	NA	WASHER, tap to pump	1	
28	GGT1117X	€2.52	CLIP, water hoses	6	
30	456-135	€15.00	HOSE, heater to demister outlet, 12"	1	
	602056	€28.08	HOSE, heater to demister outlet, 14"	1	
31	456-155	€15.00	HOSE, heater to demister outlet, 12"	1	
	602056	€28.08	HOSE, heater to demister outlet, 14"	1	
	14G800	€6.48	CLIP, hose	4	
34	635-550	€25.32	MASK ASSEMBLY, demister vent	2	
35	PFS106	€0.72	NUT, spire	6	

Fresh Air System

40	13H58X	€47.64	HOSE, 4" dia., fresh air supply	1	
	NA		CLIP, hose to radiator grille	1	
42	14G800	€6.48	CLIP, hose to air valve, strap type, pin drive	1	OE type
	326-365	NA	CLIP, hose to air valve, strap type, hex drive	1	alternative
43	326-235	€13.80	CLAMP, hose to wheelarch	1	
44	PMZ308	€0.72	SCREW, clamp to wheelarch	1	
45	GHF331	€0.84	WASHER, locking	1	
46	NA		WASHER, plain	2	
47	GHF206	€1.32	NUT	1	
50	363-115	€157.20	VALVE ASSEMBLY, fresh air	1	
51	NA		BODY, fresh air valve	1	
52	NA		DISC VALVE	1	
	NA		SEAL, on disc	1	
	NA		STRAP, disc	1	
55	NA		LEVER, valve control	1	
	GHF300	€1.08	WASHER, plain	2	
58	NA		SCREW, fixing cable to lever	1	
60	17H1597	€6.12	MESH, fresh air valve	1	
61	NA		SCREW, air valve to bulkhead	3	
	NA		WASHER, plain	3	
	GHF331	€0.84	WASHER, locking	3	
	GHF206	€1.32	NUT	1	
	4G4920	€3.48	PLUG, in scuttle, fresh air inlet	1	
70	331-310	€70.32	CABLE, with knob, fresh air control	1	
	NA		MOUNTING BRACKET, under dash	1	
80	NA		CLAMP, cable to mounting bracket	1	
	NA		SCREW, clamping cable to bracket	1	
	NA		SCREW, mounting bracket to body	1	
	NA		WASHER, plain	2	
	GHF206	€1.32	NUT	1	
	RFN403	€1.80	GROMMET, cable through bulkhead	1	
	363-395	€30.72	BRACKET KIT, cold air control	1	
	SE910201	€1.08	SCREW, fixing bracket	2	
	GHF331	€0.84	WASHER, locking	2	
	NA		WASHER, plain	4	
	GHF206	€1.32	NUT	2	
100-6, 3000 Heater Assembly					
91	14B6599	NA	HEATER ASSEMBLY	1	
92	363-165	NA	HEATER BOX, top	1	
93	363-175	€32.16	HEATER BOX, bottom	1	
94	27H1173	€298.80	HEATER CORE	1	
95	NA		SCREW, radiator mounting	2	
96	363-375	€3.36	CLIP, spring	3	
97	363-430	€146.76	AIR INTAKE ASSY (with housing)	1	
98	363-425	NA	VALVE ASSEMBLY, air inlet	1	
99	17H1607	€14.28	SEAL, air inlet	1	
105	PMZ308	€0.72	SCREW	9	
106	NA		WASHER, plain	14	general hardware used in heater system
107	GHF331	€0.84	WASHER, locking	22	
108	GHF206	€1.32	NUT	10	
109	AB606031	€0.84	SCREW	11	

ill.	Part Number	Price €ea.	Description	Req.	Details
Water Pipes and Control Valves					
113	NA		HOSE, inlet, tap on engine to valve	1	
114	835-620	€90.60	HEATER CONTROL TAP (on engine)	1	
115	12H3868	€1.08	GASKET	1	
116	27H1171	€32.76	HEATER CONTROL VALVE	1	
117	C9928A	€1.44	O RING, heater valve to adaptor	1	
117a	C9928A	€1.44	O RING, heater core seal	1	
118	PMZ308	€0.72	SCREW, valve mounting	2	
119	NA		HOSE, outlet, heater to return pipe	1	
120	NA		GROMMET, heater box	1	
121	NA		GROMMET, bulkhead	2	
122	NA		PIPE, water return (no mtg. tabs)	1	very early BN4
	NA		PIPE, water return	1	BN4 thru BN7/BT7 2 carb
	NA		PIPE, water return	1	BN7, BT7 tri-carb
	363-245	€72.00	PIPE, water return	1	BJ7, BJ8
123	MM326-250	€3.12	CLIP, inlet & return hoses	4	band type
	CS4012	€2.16	CLIP, inlet & return hoses	4	wire type
124	021-630	€22.20	ADAPTOR, heater valve	1	

Cold Air to Heater

130	14B9821	€28.68	HOSE, 4" dia., cold air to blower	1	
	14G800	€6.48	CLIP, for 4" dia. hoses, steel strap	3	BN4, BN6
131	GHC11120	€8.64	CLIP, for 4" dia. hoses, wire type	3	BN7, BT7
	NA		CLIP, for 4" dia. hoses, band type	3	BJ7, BJ8
132	AHH5714	€4.32	CLAMP, hoses to wheel arches	2	
133	SE910201	€1.08	SCREW, clamp	2	
135	363-075	NA	HEATER ASSEMBLY, blower	1	
136	17H819	€98.76	CASING	1	
137	17H1597	€6.12	MESH, intake	1	
	363-325	NA	MOTOR AND FAN ASSY.	1	
139	NA		MOTOR	1	
	515825	€16.20	FAN, metal	1	alternative to plastic fan
	27H602	NA	NUT, collet	1	
	17H8108	€16.20	FAN, plastic	1	alternative to metal fan
	17H6836	NA	RING, compression	1	
144	27H1232	€3.72	GROMMET, blower mounting	4	
145	27H1258	€1.56	SPACER	4	
146	363-345	€10.20	BRACKET, blower	2	
147	CRCP302	€5.40	PLATE, Smiths, riveted	1	
148	GHF600	€0.84	RIVET	2	
150	NA		BOLT, blower assembly mounting	4	
151	NA		WASHER, special	4	
152	NA		NUT, spire	4	
	NA		SCREW, ground, blower to wheel arch	1	
154	14B6601	€35.64	HOSE, 3 1/4" dia., blower to heater	1	
155	CS4052	NA	CLIP, 3 1/4" dia. hose, wire type	2	BN4, BN6, BN7, BT7
	NA		CLIP, 3 1/4" dia. hose, band type	2	BJ7, BJ8

Hot Air Outlets

160	14G3499	€12.96	ELBOW ASSEMBLY, hot air	4	
161	AHH5427	€14.16	HOSE, defroster	2	
163	635-550	€25.32	MASK, demister vent	2	
164	PFS106	€0.72	NUT, spire	6	
165	13H59	NA	LID, hot air outlet	2	
	13H59SS	€54.60	LID, hot air outlet, stainless steel	2	with screws

Fresh Air System

170	363-155	NA	INTAKE ASSEMBLY, fresh air	1	
171	17H1597	€6.12	MESH, fresh air intake	1	
172	13H58X	€47.64	HOSE, 4 dia., fresh air	1	
173	HMP290049	€15.00	FLANGE, bulkhead, fresh air	1	
174	17H1597	€6.12	MESH, bulkhead flange (replacement)	1	
175	NA		BEZEL, bulkhead flange	1	
176	AB610031	€0.72	SCREW, flange	3	

Heater Controls

180	13H77	€18.00	PANEL, heater control	1	
181	27H1208K	€9.24	MOUNTING KIT, control panel	2	
182	612262	€38.04	CABLE, heater air inlet control	1	LHD
183	17H1494	€7.92	KNOB, heater air control cable	1	
184	611284	€43.68	CABLE, fresh air control	1	
185	17H1493	€7.92	KNOB, fresh air control cable	1	
186	PCR307	€2.16	CLIP, fresh air control cable	1	
187	CMZ305	€1.20	SCREW, clip	1	
190	13H78	€66.96	LEVER & SWITCH ASSEMBLY (fan switch & water valve control lever)	1	all except 100-4
191	NA		CLAMP, cable	2	
192	NA		SCREW, clamp	2	
193	021-584	€2.52	SCREW, lever control knob	1	
194	13H76	€7.44	KNOB, lever control	1	
195	331-360	€10.20	CABLE, water valve control	1	LHD plus all BJ8
	NA		CABLE, water valve control	1	RHD except BJ8
196	24G1482K	€2.40	TRUNNION KIT, cables	4	

The heater hoses go under the defroster hoses, and they must cross. The hose from the heater valve goes to the valve on the side of the head, and the other from the right front of the heater box to the heater pipe on the manifold. If these hoses are connected the other way, the water will not flow through the heater valve into the heater. (Thanks to Norman Nock.)

ill. Part Number Price €ea. Description Req. Details

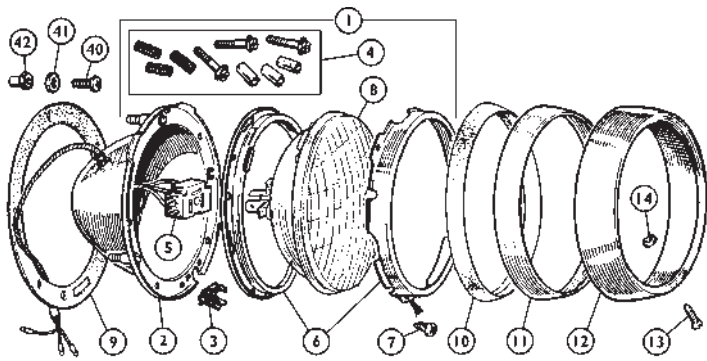

Headlamp, 3-adjusters
U.S.A thru BN7 (c)2275, BT7 (c)2176

1	144-790	NA	HEADLAMP ASSEMBLY	2	
2	7H6838	€23.04	BUCKET (without adjusters)	2	
3	37H7421A	€3.00	CLIP, rim retaining	2	
4	17H5394K	€6.24	ADJUSTER SET	2	
5	BAU2110	€9.00	WIRING HARNESS, headlamp loom	2	sealed beam, no pilot
	171-401	€5.76	GROMMET, for headlamp wires	1	BN7, BT7
6	17H5205	€37.92	MOUNTING RING SET	2	
Note: Later type mounting rings may be supplied in sub-assembly.					
7	AB606021	€0.84	SCREW, ring retaining	6	
8	BMK2508	NA	HEADLAMP UNIT, GE, 60/50w	2	no pilot (not in assy),
	BMK2508H	€29.40	HEADLAMP UNIT, halogen, 60/50w	2	sealed beam, LHD
	GLU501	€84.84	HEADLAMP UNIT, BPF, no pilot	2	RHD
	GLB414	NA	BULB, BPF	2	
9	502211	€8.28	SEAL, bucket to body	2	
10	3H2962	€6.00	SEAL, rim to bucket	2	
11	500929	€28.08	RIM, headlamp, chromed	2	BN1-BN2 (orig. type)
	500929ALLOY	€43.44	RIM, headlamp, polished aluminium	2	BN-BN2 (replacement)
12	37H5530	€57.48	RIM, headlamp	2	BN4, BN6, BN7, BT7
13	323-090	€1.56	SCREW, machine, rim retaining	2	as fitted
	RTC465	€1.08	SCREW, self-tapping	2	
14	21G9057	€0.96	WASHER, screw retaining (rubber)	2	

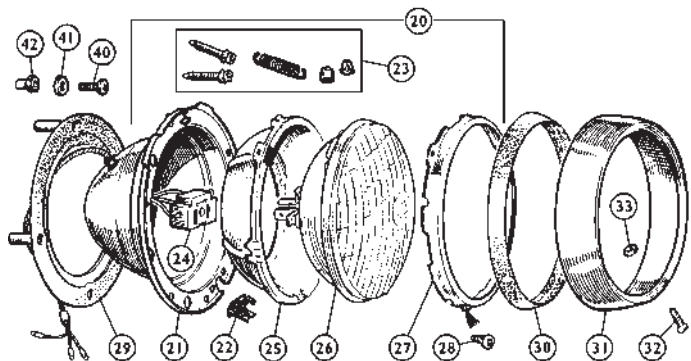

Headlamp, 2 adjusters
U.S.A from BN7 (c)2276, BT7 (c)2177 thru BJ8

20	144-800	€118.80	HEADLAMP ASSEMBLY, sealed beam	2	no pilot, LHD
21	SML3	€25.80	BUCKET, with adjusters	2	
22	37H7421A	€3.00	SPIRE CLIP, rim retaining	2	for screw #32
23	BHM7058	€6.96	ADJUSTER SET	2	
24	BAU2110	€9.00	WIRING HARNESS, headlamp loom	2	sealed beam, no pilot
	171-401	€5.76	GROMMET, for headlamp wires	1	BN7 from (c)2276, BT7
					from (c)2177, BJ7, BJ8
25	SML4	€14.28	MOUNTING RING, inner, metal	2	
26	BMK2508	NA	HEADLAMP UNIT, GE, 60/50w	2	sealed beam, no pilot
	BMK2508H	€29.40	HEADLAMP UNIT, halogen, 60/50w	2	(not in assy), LHD
27	156-700	NA	MOUNTING RING, outer	2	
28	AB606021	€0.84	SCREW, ring retaining	6	
29	009403	€6.60	SEAL, bucket to body	2	
30	3H2962	€6.00	SEAL, rim to bucket	2	
31	37H5530	€57.48	RIM, headlamp	2	
32	RTC465	€1.08	SCREW, rim retaining	2	
33	21G9057	€0.96	WASHER, screw retaining	2	

ill. Part Number Price €ea. Description Req. Details

Headlamp Notes

Although a great variety of headlamps was fitted to different Austin-Healey models at the factory to suit different markets and driving conditions, we have selected the two main U.S.A. versions, which appear to the left. It is believed that very few, if any, cars were sold in the U.S. with other than sealed-beam headlamps, as the distributor or dealers installed these until the factory began fitting them with the change to the two-adjuster units.

For those owners who prefer the attractive and popular "tripod" units, we are pleased to offer reproduction PL700 light units. The "PL" units are a higher performance version, and feature the attractive "Lucas PL" shield. Please note that tripod units are not DOT approved, and are not legal for street use where DOT approved headlamps are required.

Headlamp to Body Hardware

40	PMZ312	€1.44	SCREW	8
41	GHF331	€0.84	LOCKWASHER	8
42	310-155	€4.56	NUT, original type, brass	8
	HN2005	€0.84	NUT, replacement	8



A B C

Halogen Headlamps

A	LULUB314	€111.12	HALOGEN HEADLAMP, Lucas	2
B	902-969	€117.00	HALOGEN HEADLAMP, Hella	2
C	156-875	NA	HALOGEN HEADLAMP, Crystal Clear	2
	GLB472	€8.16	BULB, H4 halogen	2

See accessories section at the front of this catalogue for details.



PL700 Tripod Headlamp Pair

The PL700 was fitted to many high level sports cars. The unique lens design and prominent PL badge give a distinct look that is part of the historical heritage of our cars. These are semi-sealed units, and are not legal where D.O.T. approved headlamps are required.

156-898	€177.48	PL700 SET
GLB410	€4.80	REPLACEMENT BULB
GLB2983	€10.20	BULB, QUARTZ HALOGEN

Wipac Headlamp Conversions

Fitting modern H4 halogen headlamps is one of the most worthwhile safety improvements you can make to your classic, offering a better light output, and with the convenience of being able to change just the bulb instead of the whole unit should it need replacing.

NI	GAC4022	€73.32	HEADLAMP CONVERSION, no pilot	1	RHD
	MGE203	€96.60	HEADLAMP CONVERSION, no pilot	1	LHD
	GAC4023Z	€84.60	HEADLAMP CONVERSION, with pilot	1	RHD
	WPS4699	€99.84	HEADLAMP CONVERSION, with pilot	1	LHD

iii. Part Number Price €ea. Description Req. Details

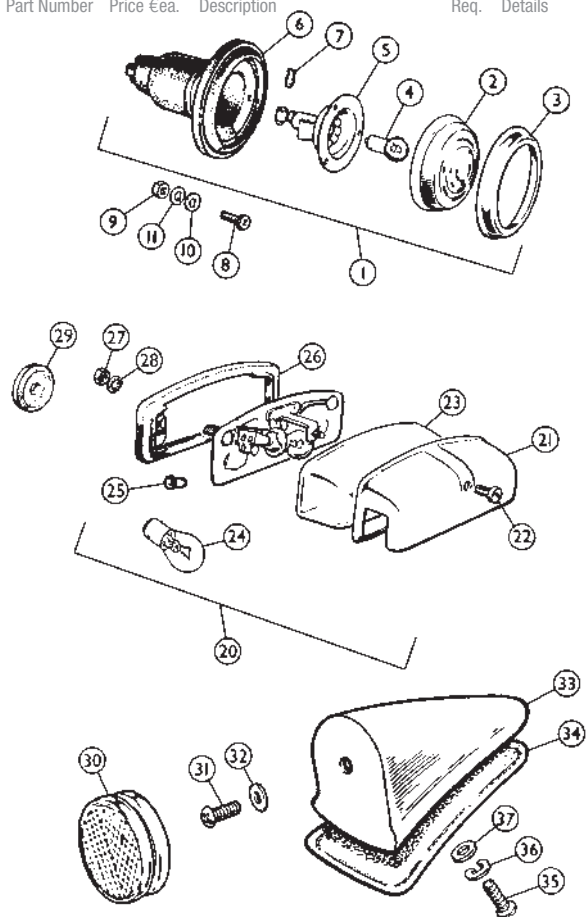

Front and Rear Lamps: BN1, BN2 (Lucas model 488)

1	3H3055	€35.40	LAMP ASSEMBLY, clear lens	2	front side and flasher
2	AJA5076	€11.16	LENS, clear	2	
	3H1814	€32.40	LAMP ASSEMBLY, red lens	2	rear stop/tail and flasher
	7H5183	€11.88	LENS, red	2	
3	7H5182	€3.96	RIM, chrome	4	
4	GLB380	€0.96	BULB	4	
5	17H5426	€23.16	BULB HOLDER	4	
6	37H5481	€6.84	GAITER, rubber	4	
7	27H6713	€2.76	BULLET CONNECTOR, solderless	A/R	not in assembly
8	NA		SCREW, lamp attaching	12	
9	NH806011	€0.96	NUT, lamp attaching	12	
10	NA		WASHER, plain	12	
11	WL700061	€0.72	WASHER, locking	12	

Number Plate Lamp: BN1, BN2

20	127916X	€76.20	NUMBER PLATE LAMP, "England"	1
	127916	€47.52	NUMBER PLATE LAMP, Classic Gold	1
21	502264	€15.72	COVER	1
22	17H5385	€3.48	SCREW, cover	1
23	601721A	€8.40	LENS, glass	1
24	GLB989	€1.56	BULB (stock type)	1/2
	GLB989LW	NA	BULB, LED replacement	1/2
25	27H6713	€2.76	WIRE TIP, solderless	2
26	57H5368	€5.88	SEAL, rubber	1
27	AJD8012Z	€0.72	NUT, lamp attaching	2
28	GHF331	€0.84	WASHER, locking	2
29	NA		GROMMET, cable	1

Reflector Assembly: BN1, BN2 (as fitted)

30	144-700	€27.84	REFLECTOR ASSEMBLY	2
31	PMZ308	€0.72	SCREW, reflector to plinth	2
32	NA		WASHER, plain	2
33	544-680	€72.00	PLINTH, LH	2
	544-690	€72.00	PLINTH, RH	2
34	14B3869	€7.80	PLINTH PAD	2
35	PMZ308	€0.72	SCREW, plinth to body	4
36	GHF331	€0.84	WASHER, locking	4
37	NA		WASHER, plain	4

iii. Part Number Price €ea. Description Req. Details

Lamps 100-6, 3000
Lamps: BN4, BN6, BN7, BT7,
BJ7, BJ8 to (c)26704

(Lucas model 594)

The model 594 Lucas lamp was fitted to six cylinder Austin Healey cars in many different lens color and filament quantity permutations, not to mention on the front, back, or both. The Lucas model 594 lamp is often referred to as the 'beehive lens' lamp and fits with three fasteners into piercings in the bodywork.

Quantities for fitment have been omitted due to the numerous changes and varied usage. We hope you would know how many lamps your car should have fitted. To further aid identification, the overall diameter of the 594 lamp is 2 7/8".

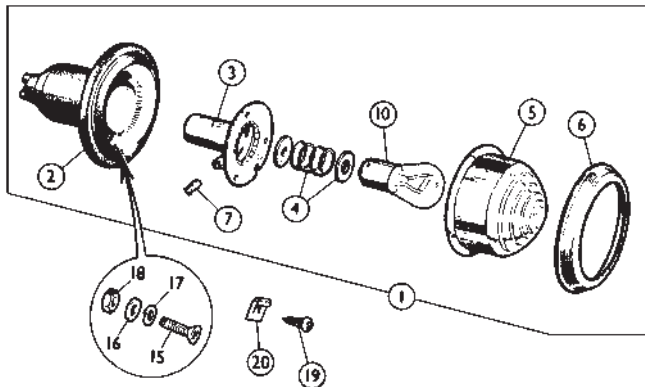

Lucas 594 Lamp

1	1B9100	€27.12	LAMP ASSEMBLY, clear lens	A/R	5/21W side / flasher lamp
	1B9101	€27.12	LAMP ASSEMBLY, red lens	A/R	tail and stop lamp
2	508162	€4.44	RUBBER GAITER	A/R	short, approx. 2-3/8"
	37H5481	€6.84	RUBBER GAITER	A/R	long, approx. 3-1/4"
3	27H5454	€13.44	BULB HOLDER ASSEMBLY, for twin filament bulb	A/R	} replacement type
4	37H5459	€5.88	BULB CONTACT KIT, for twin filament bulb	A/R	
5	37H6928Z	€8.16	LENS, clear	A/R	
	37H5531Z	€8.16	LENS, red	A/R	
	37H5520Z	€8.16	LENS, amber	A/R	
6	7H5182	€3.96	RIM, lens retaining, chromium	A/R	
7	27H6713	€2.76	BULLET CONNECTOR (solderless type)	A/R	

Note: Light bulbs for certain European markets were originally specified in power ratings which may not be listed.

10	GLB380	€0.96	BULB, twin filament, 21/5W 12 volt, A/R		stop/ tail and side/flasher lamp
----	--------	-------	---	--	----------------------------------

Attaching Hardware

15	NA	SCREW, pan head	3 per lamp		
16	NA	WASHER	3 per lamp		
17	WL700061	€0.72	WASHER, locking	3 per lamp	
18	NH806011	€0.96	NUT	3 per lamp	
19	GHF421	€0.84	SCREW, self tapping	3 per lamp	} alternative
20	AK606021	€1.80	SPIRE NUT	3 per lamp	

iii. Part Number Price €ea. Description Req. Details

Lamps: BJ8 from (c)26705
(Lucas models 691 and 692)

The other type of side, indicator or tail lamp used on the Austin Healey 3000 was the Lucas 691 or 692 model. This is easily distinguishable by its lens attachment of two studs and nuts. The lenses of these lamps are plastic, and the overall diameter of the lamp is 3-1/4".

BJ8s from May 1964 (c)26705 through March 1965 (b) 76137 had two front parking/flasher lamps with clear lenses and dual-filament bulbs (BHA4465).

From March 1965 (b)76138 the front lamp functions were split into separate lamps to comply with USA regulations. The new lamps had single-filament bulbs. The turn signal flasher lamp (BHA4477) had an amber lens, while the parking lamp (BHA4476) had a clear lens.

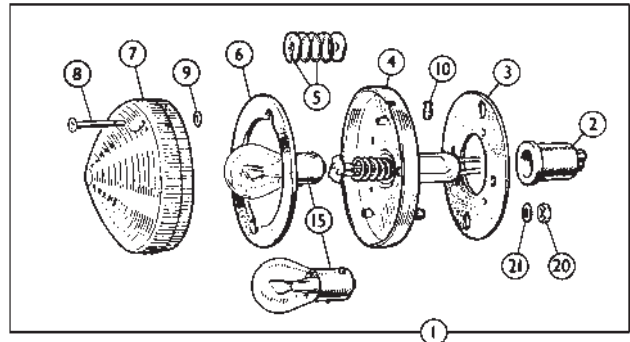

Lucas 691/692 Lamps

1	BHA4465	€35.64	SIDE/INDICATOR LAMP, front,	2	clear lens, 5/21W
	BHA4476	€34.32	INDICATOR LAMP, front, clear lens, 5W	2	
	BHA4477	€32.64	FLASHER LAMP, front, amber lens, 21W	4	
	BHA4477	€32.64	FLASHER LAMP, rear, amber lens, 21W	4	all
	BHA4462	€34.44	STOP/TAIL LAMP, red lens, 5/21W	2	all
2	17H5216	€1.80	BOOT, single wire	A/R	single filament bulbs
	37H5525	€2.76	BOOT, 2-wire	A/R	dual filament bulbs
3	27H2724	€4.92	GASKET, lamp body seating	A/R	
4	27H2725	NA	BULB HOLDER & LAMP BODY	A/R	twin filament bulb
	27H4886	NA	BULB HOLDER & LAMP BODY	A/R	single filament bulb
5	37H5459	€5.88	BULB CONTACT KIT	A/R	for twin filament bulb
	37H5452	€6.72	BULB CONTACT KIT,	A/R	for single filament bulb
6	17H6765	€1.80	GASKET, lens seating	A/R	
7	17H6763	€11.52	LENS, clear	A/R	
	517266	€10.92	LENS, amber	A/R	
	37H6109	€13.92	LENS, red	A/R	
8	518868	€1.44	SCREW, for lens	8	
9	21G9057	€0.96	WASHER, retaining screw	A/R	
10	27H6713	€2.76	BULLET CONNECTOR	A/R	for ground wire to lamp- if fitted

Note: Light bulbs for certain European markets were originally specified in power ratings which may not be listed.

15	GLB207	€1.44	BULB, single filament	A/R	5W side/parking lamp
	LULLB382	€1.56	BULB, single filament	A/R	21W flasher lamp
	GLB380	€0.96	BULB, twin filament	A/R	21W/5W stop/tail & flasher/side lamp

Attaching Hardware

20	HN2005	€0.84	NUT, lamp attachment	2 per lamp	
21	WL700101	€1.20	WASHER, locking	2 per lamp	internal star type

iii. Part Number Price €ea. Description Req. Details

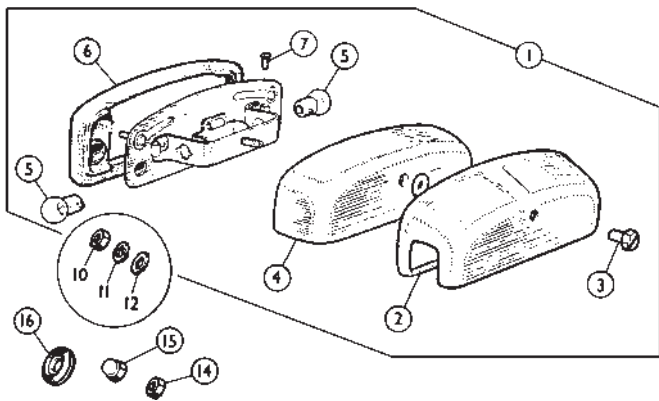

Number Plate Lamp: All 100-6, 3000

1	127916X	€76.20	NUMBER PLATE LAMP, "England"	1	
	127916	€47.52	NUMBER PLATE LAMP, Classic Gold brand	1	
2	502264	€15.72	COVER	1	
3	17H5385	€3.48	SCREW, cover	1	
4	601721A	€8.40	LENS, glass	1	
5	GLB989	€1.56	BULB (stock type)*	A/R	
	GLB989LW	NA	BULB, LED replacement	A/R	
6	57H5368	€5.88	SEAL, rubber	1	
7	27H6713	€2.76	BULLET CONNECTOR, solderless	2	
10	AJD8012Z	€0.72	NUT, lamp attaching	2	
11	GHF331	€0.84	WASHER, locking	2	
12	NA		WASHER, plain	2	
14	NA		NUT	2	BN4, BN6, BN7, BT7
15	NA		DOME NUT	2	BJ7, BJ8
16	NA		GROMMET, cable	1	

*Note: Original number plate lamps may contain one or two bulbs. Both of the lamps we supply contain two bulbs.

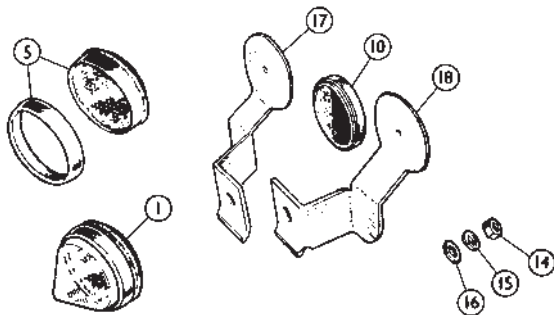

Reflectors: All 100-6, 3000

1	1B9056	NA	REFLECTOR ASSEMBLY, conical	2	BN4, BN6 (as fitted)
5	BHA4149	€45.84	REFLECTOR ASSEMBLY, fiat	2	BN6 (as fitted); BN7, BT7, BJ7, BJ8 to (b)76137
10	BCA4871	€29.52	REFLECTOR ASSY, screw fixing*	2	
14	AJD8012Z	€0.72	NUT	2	
15	WL700101	€1.20	WASHER, locking	2	BJ8 from (b)76138
16	PWZ203	€0.96	WASHER, plain	2	
17	AHB8985	€19.08	BRACKET, reflector mounting, LH	1	
18	AHB8984	€19.08	BRACKET, reflector mounting, RH	1	

*Note: items 10 to 18 may be fitted to earlier 100/6s and 3000s, without modification, thus equipping earlier cars with larger, safer, auxilliary reflectors.

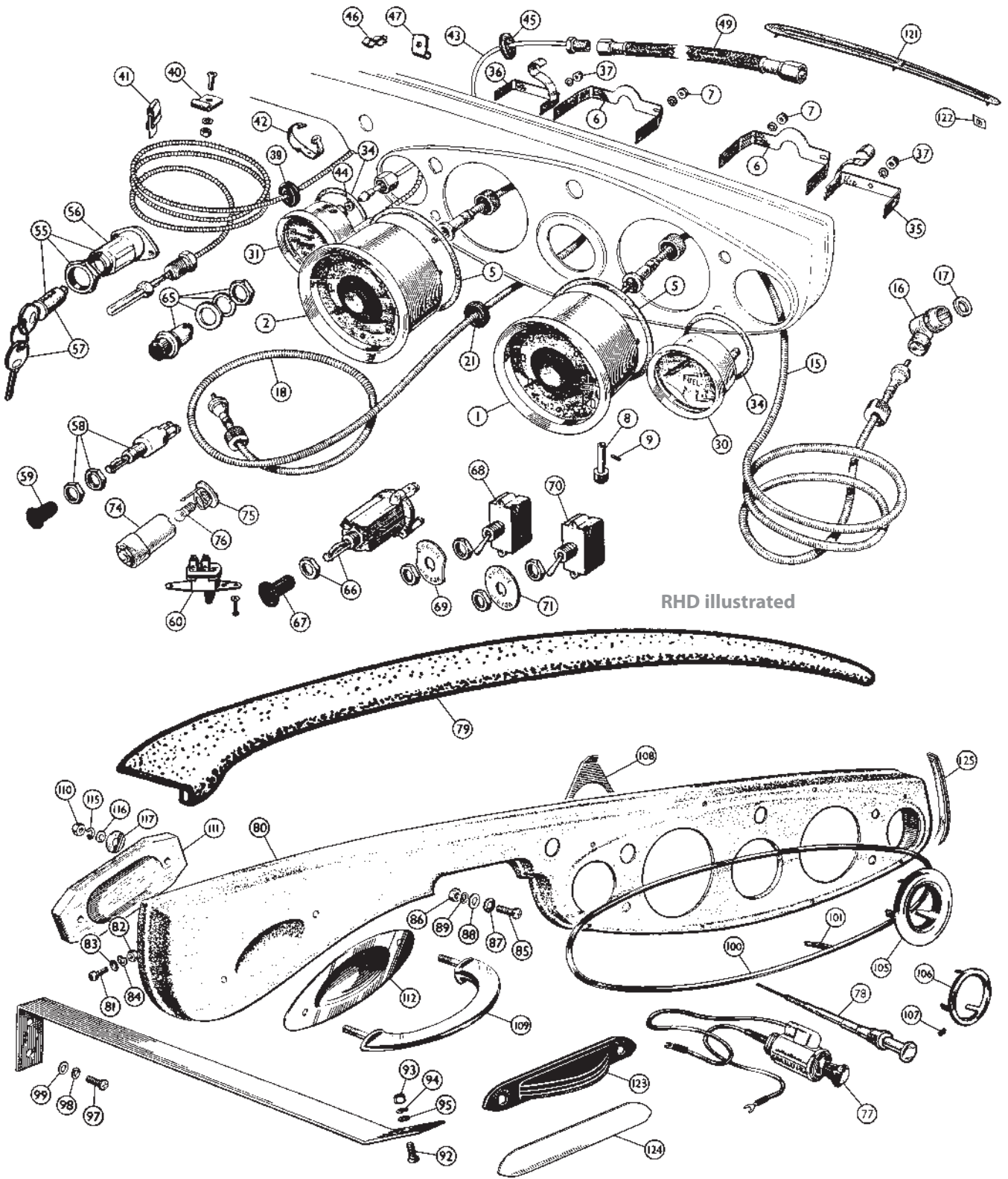

Ill.	Part Number	Price €ea.	Description	Req.	Details	Ill.	Part Number	Price €ea.	Description	Req.	Details
Dashboard BN1 to BJ7						Dashboard BN6 to BJ7					
1	021-490	NA	GAUGE, speedo, exchange, MPH, (SN6305/00)	1	BN1, BN2, std, 4.125:1	73		NA	CONTROL HEAD	1	
	1B9059E	NA	GAUGE, speedo, exchange, MPH, (SN6105/06)	1	BN4, BN6, non-overdrive	74	128378	€16.80	WARNING LAMP, indicators	1	
	1B9057E	NA	GAUGE, speedo, exchange, MPH, (SN6105/08)	1	BN4, BN6, with overdrive	75	502342	€13.32	BULB HOLDER, warning lamp	1	
	021-499	NA	GAUGE, speedo, exchange, MPH, (SN6155/19)	1	BN7, BT7, BJ7, non-overdrive, 3.54:1	76	GLB987	€1.20	BULB, dash lamps	7	
	BHA4126E	€113.64	GAUGE, speedo, exchange, MPH, (SN6155/21)	1	BN7, BT7, BJ7, w/overdrive, 3.909:1	77	AHH7010	€29.28	CIGARETTE LIGHTER	1	optional, period type
2	021-512	NA	GAUGE, tachometer, exchange, (RN2301/00)	1	BN1, BN2, 100M	78	734-100	€42.48	CHOKE CABLE	1	BN1, BN2
	021-515	NA	GAUGE, tachometer, exchange, (RN2301/01)	1	BN4 to C.E.68959		734-130	€23.88	CHOKE CABLE	1	BN4 from C.E.48863, BN6, BN7, BT7
	1B9188E	NA	GAUGE, tachometer, exchange, (RN2301/03)	1	BN4 from C.E.68960, BN6, BN7, BT7, BJ7		AHB6021	€37.44	CHOKE CABLE	1	BJ7, BJ8
	27H397	€20.88	BEZEL, tach & speedo	2		79	SC7630	€183.12	DASH TOP, padded, black	1	
	AJH5177	€12.36	GLASS	2			805-670	€183.12	DASH TOP, padded, red	1	BN4, BN6, BN7, BT7
5	AJH5178	€1.92	RING, sealing	2			805-675	€183.12	DASH TOP, padded, blue	1	
6		NA	STRAP, fixing	2			633-850	€216.36	DASH TOP, padded, black	1	BJ7
7	17H932	€2.16	NUT, thumb	4		80	633-625	€448.80	DASH PANEL, LHD (RHD illus.)	1	BN1, BN2
8		NA	KNOB, speedometer trip reset	1				NA	DASH PANEL, LHD	1	BN4 to C.E.68959
9		NA	SCREW, knob	1			633-635	€598.80	DASH PANEL, LHD	1	BN4 from C.E.68960, BN6, BN7, BT7, BJ7
15	1B3645	€27.12	CABLE, speedometer, 63"	1	BN1, BN2			NA	INSTRUMENT PANEL	1	
	GSD104	€49.80	CABLE, speedometer, 54", non-overdrive	1	BN4, BN6, BN7 to (c)5588, BT7 to (c)6774		53K126	€1.08	SEAL, plastic	1	BN1 to (b)1853
	GSD109	€26.04	CABLE, speedometer, 63", overdrive	1			GHF331	€0.84	SCREW, locking	8	
	GSD111	€19.68	CABLE, speedometer, 48", non-overdrive	1	BN7 from (c)5589 to 16038, BT7 from (c)6775 to 15880		81	NA	SCREW, panel to end fixing bracket	4	
	GSD104	€49.80	CABLE, speedometer, 54", overdrive	1			82	€1.32	NUT	4	
	021-385	€17.88	CABLE, speedometer, 42", non-overdrive	1	BN7 from (c)16039, BT7 from (c)15881, BJ7c		83	NA	WASHER, plain	4	
	GSD113	€35.40	CABLE, speedometer, 51", overdrive	1			84	€0.84	WASHER, locking	4	
16	768-020	€161.52	ANGLE DRIVE	1	BN1, BN2		85	NA	SCREW, panel to centre bracket	1	
	120694	€63.00	ANGLE DRIVE	1	BN4, BN6, BN7, BT7, BJ7		86	€1.32	NUT	1	
17	3H550	€1.20	WASHER, copper	1			87	NA	WASHER, chrome	1	
18	1B2731	€19.80	CABLE, tachometer, 33", LHD	1	BN1, BN2		88	€1.20	WASHER, plain	1	
	1B9141	€22.32	CABLE, tachometer, 48", LHD	1	BN4, BN6, BN7, BT7, BJ7		89	€0.84	WASHER, locking	1	
		NA	CABLE, tachometer, 33", RHD	1	BN1, BN2		91	€0.72	SCREW, self tapping	2	
		NA	CABLE, tachometer, 33", RHD	1	BN4, BN6, BN7, BT7, BJ7		92	€1.32	SCREW, bracket to panel	1	
21	ACB8474	€2.76	GROMMET, cable through bulkhead	1			93	€1.32	NUT	1	BN6, BN7, BT7, BJ7
30	021-545	NA	FUEL GAUGE (FG2530/19)	1	BN1, BN2		94	NA	WASHER, plain	1	
	3H3064Z	€209.64	FUEL GAUGE (replacement)	1			95	€0.84	WASHER, locking	1	
30	1B9061E	€181.80	FUEL GAUGE (FG2530/03)	1	BN4, BN6, BN7, BT7, BJ7		97	€0.72	SCREW, bracket to body	2	
	1B9061Z	€202.80	FUEL GAUGE (replacement)* *Negative ground only	1			98	NA	WASHER, plain	2	
	021-555	€295.20	OIL/WATER GAUGE, fahrenheit (GD1500/29)	1	BN1, BN2		99	€0.84	WASHER, locking	2	
31	1B9064E	NA	OIL/WATER GAUGE, fahrenheit (GD1502/00)	1	BN4 to C.E.68959, BN6 to (c)2029		100	€166.56	MOULDING, instrument panel	1	
		NA	OIL/WATER GAUGE, fahrenheit	1	BN4 from C.E.68960 to 72849, BN6 from (c)2030		101	NA	CLIP, moulding	8	
	BHA4113E	€132.12	OIL/WATER GAUGE, fahrenheit (GD1502/05)	1	BN4 from C.E.72850, BN7/BT7 to (c)14298		105	€37.44	ESCUTCHEON, steering column aperture, non-adjustable steering	1	BN4, BN6, BN7, BT7, BJ7
		NA	OIL/WATER GAUGE, centigrade	1	BN7/BT7 from (c)14299, BJ7		106	€31.44	ESCUTCHEON, adjustable steering	1	
	AJH5182	€19.20	BEZEL, 2" gauges	2			107	NA	SCREW, escutcheon, adjustable strg.	1	
	502269F	€8.52	GLASS	2			108	€16.80	PLATE, escutcheon retaining	1	
34	17H1642	€1.20	RING, sealing	2			109	€43.20	GRAB HANDLE	1	
35		NA	CLAMP AND LAMP HOLDER, fuel gauge	2			110	NA	NUT for repro. grab handle	2	
36		NA	CLAMP AND LAMP HOLDER	1	oil/water gauge		111	€0.96	NUT for original grab handle	2	
37		NA	NUT, thumb	4			111	€10.80	PACKING BLOCK, wood	1	
39	600395	€2.52	GROMMET, firewall	1			112	€36.84	ESCUTCHEON, handle	1	
40	PCR307	€2.16	CLIP, thermo capillary tube	A/R	BN4, BN6		115	€0.84	WASHER, locking	2	
41	1G9529	€1.08	CLIP, thermo capillary tube	2	BN7, BT7, BJ7, BJ8		116	€1.08	WASHER, plain, small	2	
42	GHF1266	€1.32	CABLE TIE, capillary to breather pipe	1	BN7, BT7, BJ7		117	€1.20	WASHER, plain, large	2	
43	836-625	NA	PIPE, oil gauge, LHD	1	BN1, BN2			NA	BUTTON, blanking use when strg. lock is fitted	1	
		NA	PIPE, oil gauge, RHD	1			121	€25.32	MASK ASSEMBLY, demister	2	
	836-630	€39.96	PIPE, oil gauge, LHD	1	BN4, BN6, BN7, BT7, BJ7		122	€0.72	NUT, spire	6	
		NA	PIPE, oil gauge, RHD	1			123	€18.00	PANEL, heater control	1	BN4 thru BJ7 (see p.107)
44	2K4936	€0.72	WASHER, leather	1			124	€60.00	PLATE, blanking	1	when heater not fitted
45	RFN403	€1.80	GROMMET, bulkhead	1	BN4, BN6, BN7, BT7, BJ7		125	NA	DRAUGHT EXCLUDER, furflex, dash edge, black	A/R	BN4 thru BJ7 sold per meter
46	6K35	€1.44	CLIP, pipe	2	RHD			611599M	DRAUGHT EXCLUDER, furflex, dash edge, red	A/R	
47		NA	CLIP, pipe	2							
	PCR307	€2.16	CLIP, pipe to bulkhead	1	BN7/BT7 from (c)13751, BJ7						
49	376-182	NA	HOSE, flexible (use 021-711)	1	BN1 - BN2						
	AHU1020	€19.80	HOSE, flexible	1	BN4 - BJ7						
55	BHA4234	NA	IGNITION SWITCH ASSY.	1							
56	107936	€33.96	SWITCH BODY	1	spade terminals						
57	24G1345	€13.20	BARREL LOCK, ignition, with two keys	1	aftermarket						
	24G1345Z	€12.24	BARREL LOCK, ignition, with two keys	1	replacement w/plain knob						
58	2H4841	€27.24	SWITCH, windscreen wiper	1							
59	106689	€7.44	KNOB, wiper switch	1							
60	BHA4698	€36.84	SWITCH, panel light	1							
65	872-091	NA	SWITCH, starter push	1	"S" on knob						
	3H3058	€17.88	SWITCH, starter push	1	replacement w/plain knob						
66	3H3098	€40.08	SWITCH, head & sidelamp	1							
67	106685	€14.40	KNOB, lighting switch	1							
68		NA	SWITCH, overdrive	1	BN1						
69	633-665	€27.12	ESCUTCHEON, overdrive switch	1							
70	141-240	€15.72	SWITCH, overdrive	1	BN2 thru BJ7						
71	633-660	€21.24	ESCUTCHEON, overdrive switch	1	BN2 thru BJ7						
72		NA	DIP SWITCH, headlamps	1							

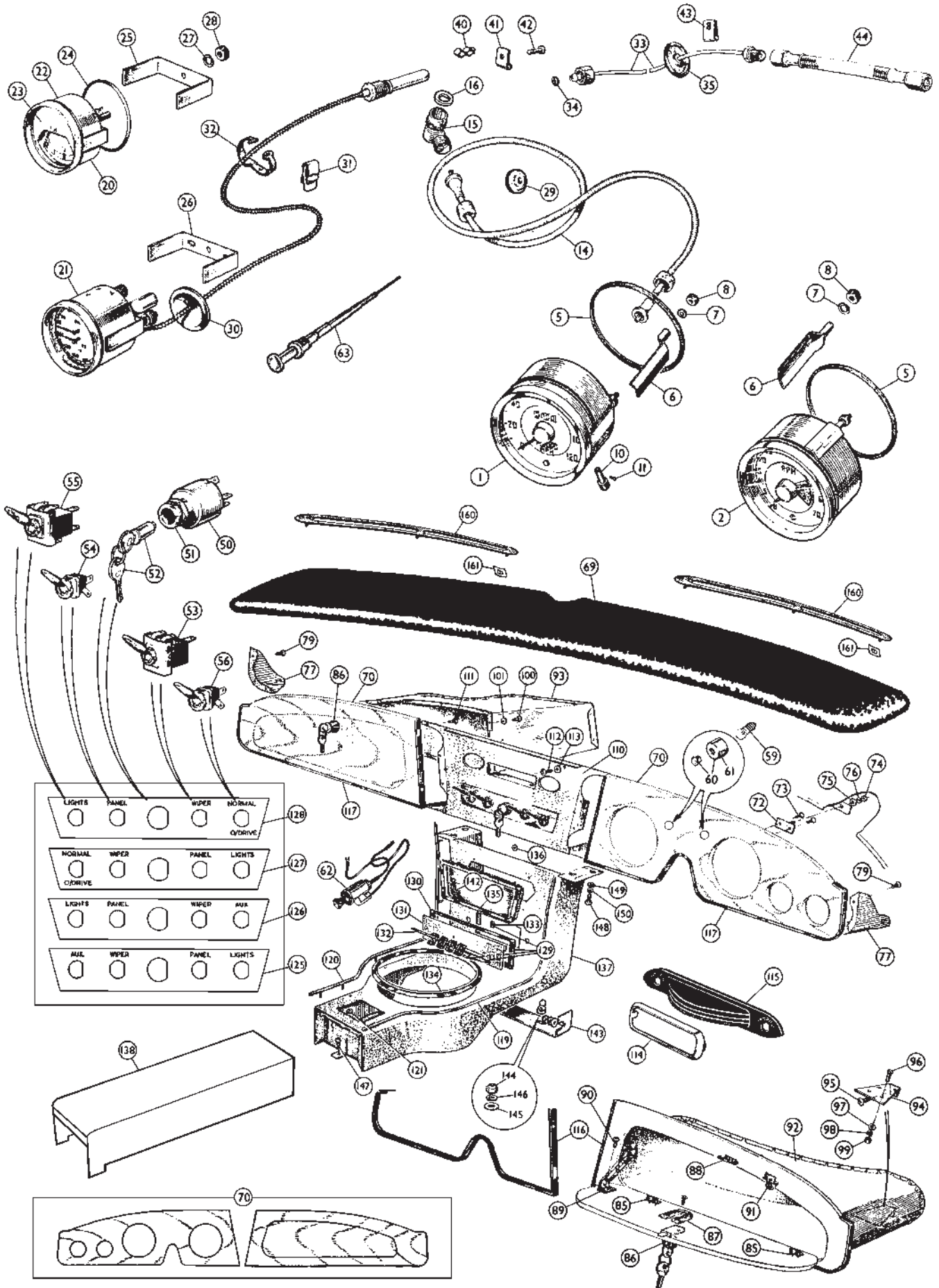

Ill.	Part Number	Price €ea.	Description	Req.	Details
Dashboard BJ8					
Speedometer and Tachometer					
1	021-505	NA	GAUGE, speedo, MPH, (SN6125/20)	1	non-overdrive, 3.54:1
		NA	GAUGE, speedo, KPH, (SN6125/21)	1	
	021-508	€440.40	GAUGE, speedo, MPH, (SN6125/22)	1	with overdrive, 3.909:1
		NA	GAUGE, speedo, KPH, (SN6125/23)	1	
2	BHA4431E	€139.80	GAUGE, tachometer (RV12602/00)	1	
	27H397	€20.88	BEZEL	2	
	AJH5177	€12.36	GLASS	2	
5	AJH5178	€1.92	RING, sealing	1	
	13H784	€34.32	BLOCK, plastic (retains impulse loop wire)	1	
	27H8215	€13.08	CLIP, retainer	1	
	27H8213	€1.08	NUT, clip retaining	1	
6		NA	STRAP, fixing gauge	4	
7		NA	WASHER, locking	4	
8	17H1304	€2.16	NUT, speedo & tach	4	
10		NA	KNOB, speedometer trip reset	1	
11		NA	DOWEL	1	
14	021-385	€17.88	CABLE, speedometer, 42"	1	non-overdrive
	GSD113	€35.40	CABLE, speedometer, 51"	1	with overdrive
15	120694	€63.00	ANGLE DRIVE	1	
16	3H550	€1.20	WASHER, copper	1	

Fuel and Oil/Water Gauges

20	BHA4432E	NA	FUEL GAUGE, (FG2333/10)	1	
21	BHA4433	€283.20	OIL/WATER GAUGE, F, (GD1301/02)	1	
		NA	OIL/WATER GAUGE, C	1	
		NA	BEZEL	2	
	502269F	€8.52	GLASS	2	
24	17H1642	€1.20	RING, sealing	2	
25		NA	STRAP, fuel gauge mounting	1	
26		NA	STRAP, oil/water gauge mounting	1	
27	WL700061	€0.72	WASHER, locking	4	
28	17H932	€2.16	NUT	4	
29	C5574A	€6.60	GROMMET, speedo cable	1	
30	600395	€2.52	GROMMET, tube through bulkhead	1	
31	1G9529	€1.08	CLIP, thermo. capillary tube	2	
32	GHF1266	€1.32	STRAP, capillary to breather pipe	1	
33	836-630	€39.96	PIPE, oil gauge	1	LHD
		NA	PIPE, oil gauge	1	RHD
34	2K4936	€0.72	WASHER, leather	1	
35	RFN403	€1.80	GROMMET, pipe through bulkhead	1	
40	6K35	€1.44	CLIP, pipe	2	RHD
41		NA	CLIP, pipe	1	
42	PMZ307	€1.20	SCREW, clip	1	
43	PCR307	€2.16	CLIP, pipe to dash	1	
44	AHU1020	€19.80	HOSE, flexible	1	

Switches

50	13H337Z	€22.08	IGNITION & STARTER SWITCH	1	
51	141-305	NA	NUT, locking	1	
52	24G1345	€13.20	BARREL LOCK, ignition, with two keys	1	
	24G1345Z	€12.24	BARREL LOCK, ignition, with two keys	1	aftermarket
53	149011A	€36.12	SWITCH, windscreen wiper	1	
54	RTC430A	€7.44	SWITCH, panel light	1	
55	BCA4294	€17.28	SWITCH, head & sidelamp	1	
56	RTC430A	€7.44	SWITCH, overdrive	1	
57		NA	DIP SWITCH, headlamps	1	see page 95
58		NA	CONTROL HEAD, incorporating horn push and turn signal switch	1	see page 68
59	GLB987	€1.20	BULB, dash lamps	7/8	
60	142-260	€34.80	LENS & COVER, warning lamp	2	
61	AJG5047	€13.08	COVER, warning lamp	2	
62	AHH7010	€29.28	CIGARETTE LIGHTER	1	optional, period type
63	AHB6021	€37.44	CHOKE CABLE	1	see engine controls

Dashboard and Fittings

69	633-850	€216.36	DASH TOP, padded, black	1	
70	633-650	€538.80	DASHBOARD SET, walnut veneer	1	LHD
	633-675	€538.80	DASHBOARD SET, walnut veneer	1	RHD
72	633-715	NA	STUD PLATE	2	
73		NA	SCREW	4	
74	GHF206	€1.32	NUT	2	
75		NA	WASHER, plain	2	
76	GHF331	€0.84	WASHER, locking	2	
77	633-658	€126.48	END BRACKET SET	1	
79		NA	SCREW	6	
85	633-730	€15.36	HINGE, glove box	2	
86	633-740	€124.32	LOCK, glove box (with 2 keys)	1	
87	633-745	€50.04	COVER PLATE, lock	1	
88	633-755	€17.04	STRIKER, lock	1	
89	633-750	€35.88	STAY, glove box lid	1	
90		NA	SCREW	2	
91	633-760	€1.80	BUFFER, lid	1	

Ill.	Part Number	Price €ea.	Description	Req.	Details
92	AHB6049	€114.24	GLOVE BOX, reproduction	1	LHD
	633-591	€76.68	GLOVE BOX, moulded replacement	1	LHD
93	AHB6050	€114.24	GLOVE BOX	1	RHD
94	633-705	€11.64	BRACKET, glove box support	1	
95		NA	SCREW	1	
96		NA	SCREW	2	
97		NA	WASHER, plain	2	
98	WL700061	€0.72	WASHER, locking	2	
99	NH806011	€0.96	NUT	2	
100		NA	SCREW	12	
101		NA	WASHER, plain	12	
110	633-720	€156.36	DASH PANEL, centre	1	
111		NA	SCREW	8	
112		NA	SCREW, chrome	2	
113		NA	WASHER, chrome	2	
114	021-815	€41.64	BEZEL, control panel aperture	1	
115	13H77	€18.00	CONTROL PANEL, heater	1	(see pg. 104)
116	633-778	€249.60	FINISHER SET, dashboard	1	LHD
117		NA	FINISHER SET, dashboard	1	RHD
119		NA	FINISHER, console, RH	1] to (c)26704
120		NA	FINISHER, console, LH	1	
	633-848	NA	FINISHER PAIR, console	1	from (c)26705 (Mounting clips are not available - use your original ones.)
121		NA	WASHER, plain	14	
125	633-805	NA	SWITCH BEZEL	1	LHD
126		NA	SWITCH BEZEL	1	RHD
127	633-800	€45.72	SWITCH BEZEL	1	LHD with overdrive
128		NA	SWITCH BEZEL	1	RHD with overdrive
129	633-788	€29.40	BLANKING SET, radio aperture	1	
130	AHH5255	€9.12	BEZEL, radio aperture surround	1	
131	AHB6074	€12.96	RADIO BLANKING PLATE	1	
132	AHB8861	€17.04	BADGE, '3000'	1	
133	326-510	€0.96	SPIRE CLIP, badge fixing	2	
134	633-790	€44.52	BEZEL, gear lever	1	
135	633-785	€38.76	BEZEL, speaker surround	1	
136		NA	WASHER, plain	4	
137		NA	CONSOLE (untrimmed)	1	to (c)26704
	633-860	€211.32	CONSOLE (untrimmed)	1	from (c)26705
138		NA	BASE, arm rest (untrimmed)*	1	to (c)26704
	805-780	€88.08	BASE, arm rest (untrimmed)*	1	from (c)26705
142	633-795	€16.32	SPEAKER MESH	1	
143	805-436	€25.32	PLATE, console to gearbox cover	1	
144	GHF220	€1.32	NUT	4	
145		NA	WASHER, plain	4	
146	GHF331	€0.84	WASHER, locking	4	
147	GHF400	€0.96	SCREW	1	
148	SE910201	€1.08	SCREW	4	
149		NA	WASHER, plain	4	
150	GHF331	€0.84	WASHER, locking	4	
160	635-550	€25.32	FINISHER, defroster	2	
161	PFS106	€0.72	NUT, spire	6	
162	ACH9373	€2.16	PLUG, blanking use when steer. lock is fitted	1	

*Complete trimmed arm rest assemblies are listed on page 145.

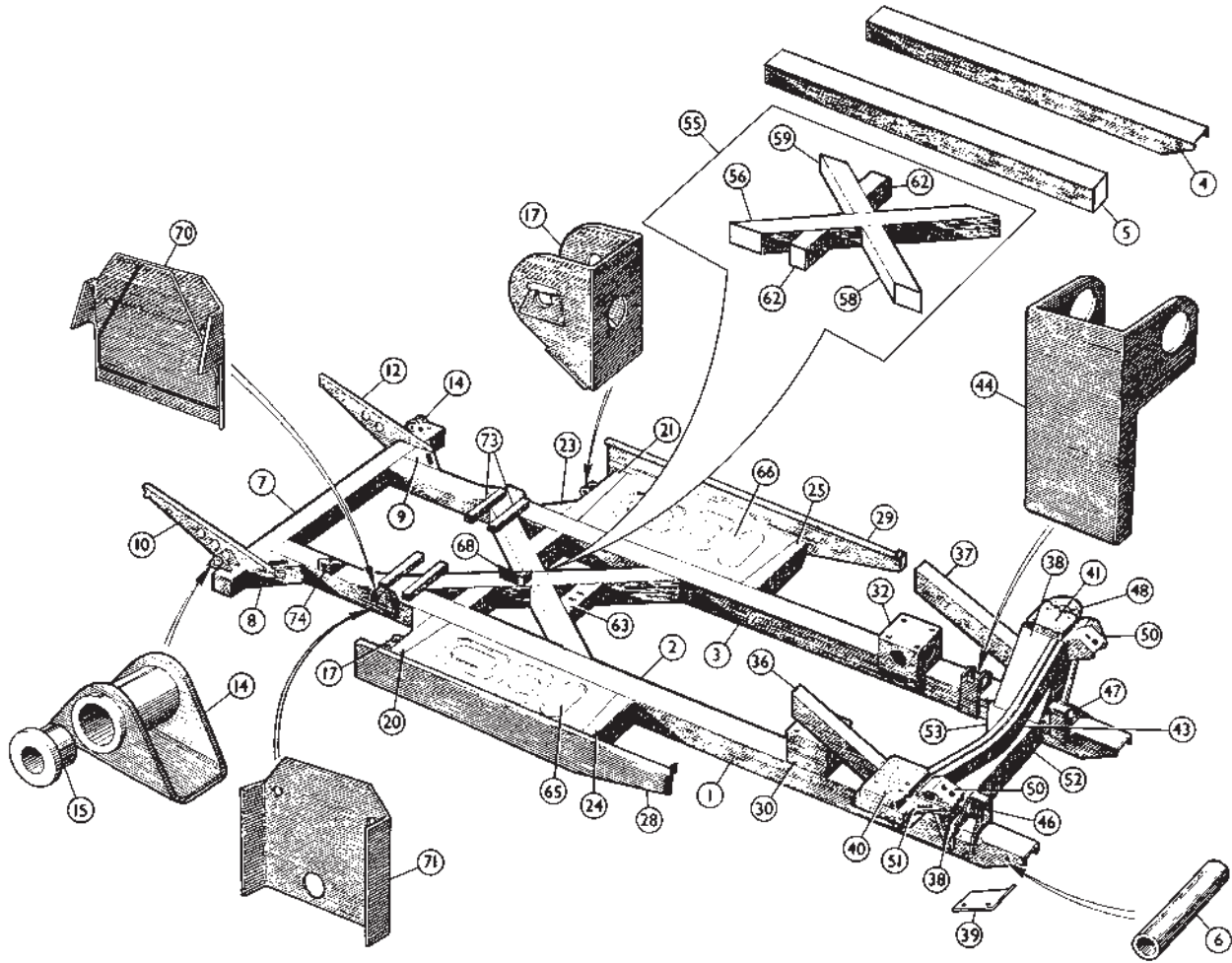

Ill.	Part Number	Price €ea.	Description	Req.	Details	Ill.	Part Number	Price €ea.	Description	Req.	Details
Chassis						856-290	NA		CROSS BRACE, main beam	1	
	1 857-800		NA CHASSIS FRAME, less outriggers, engine bearers & rear bumper extensions	1	BN1, BN2	856-175	NA		HALF CROSS BRACE, front	1	
	857-810		NA CHASSIS FRAME, less outriggers, engine bearers & rear bumper extensions	1	BN4, BN6, BN7, BT7, BJ7	856-275	NA		HALF CROSS BRACE, rear	1	
	857-820		NA CHASSIS FRAME, less outriggers, engine bearers & rear bumper extensions	1	BJ8 to (c)26704	62 856-295	NA		STIFFENER, cross brace	2	BN4 thru BJ8
	857-830		NA CHASSIS FRAME, less outriggers, engine bearers & rear bumper extensions	1	BJ8 from (c)26705	856-195	€181.92		MEMBER, gearbox mount support	1	BN1 to (c)140204
s	857-805	€1,021.20	CHASSIS RAIL, RH	1	BN1, BN2	856-335	NA		MEMBER, gearbox mount support	1	BN1 from (c)140205, BN2
	857-815		NA CHASSIS RAIL, LH	1		63 856-365	€40.44		MEMBER, gearbox mount support	1	BN4 thru BJ8
2	857-825	€1,059.60	CHASSIS RAIL, RH	1	BN4, BN6, BN7, BT7, BJ7, BJ8 to (c)26704	65 855-945	€40.32		FLOOR PANEL, RH	1	BN1, BN2
3	857-835		NA CHASSIS RAIL, LH	1	BJ8 from (c)26705	66 855-955	€40.32		FLOOR PANEL, LH	1	
	857-845		NA CHASSIS RAIL, RH	1		807-130	€202.80		FLOOR PANEL, RH	1	BN4, BN6
	857-855		NA CHASSIS RAIL, LH	1		807-140	€202.80		FLOOR PANEL, LH	1	
	857-865	€807.60	CHASSIS RAIL REPAIR, front RH	1	BN1, BN2	856-030	€40.32		FLOOR PANEL, RH	1	BN7, BT7, BJ7, BJ8
	857-875	€525.60	CHASSIS RAIL REPAIR, front LH	1		856-020	€40.32		FLOOR PANEL, LH	1	
			CHASSIS RAIL REPAIR, rear RH	1		68 856-185	€20.16		BRACKET, handbrake	1	BN4 thru BJ8
			CHASSIS RAIL REPAIR, rear LH	1		856-405	€80.40		BRACKET, rear shock mount	2	BN1, BN2
4	857-885	€579.60	CHASSIS RAIL REPAIR, front RH	1	BN4, BN6, BN7, BT7, BJ7, BJ8	70 856-415	€62.16		BRACKET, rear shock mount	2	BN4, BT7, BJ7, BJ8 to (c)26704
5	857-895	€579.60	CHASSIS RAIL REPAIR, front LH	1		71		NA	BRACKET, rear shock mount, RH	1	BN6, BN7
	856-785		NA CHASSIS RAIL REPAIR, rear RH	1				NA	BRACKET, rear shock mount, LH	1	
	856-795		NA CHASSIS RAIL REPAIR, rear LH	1		856-425		NA	BRACKET, rear shock mount, RH	1	BJ8 from (c)26705
	856-805	€816.00	CHASSIS RAIL REPAIR, rear RH	1	BJ8 from (c)26705	856-435	€62.16		BRACKET, rear shock mount, LH	1	
	856-815	€816.00	CHASSIS RAIL REPAIR, rear LH	1		73 856-588	€73.08		BRACKET SET, battery (4 pieces)	1	BN1, BN2
6	806-405	€10.56	TUBE, front bumper mounting	4	BN4 thru BJ8	74 856-515	€24.00		BRACKET, Panhard rod	1	BN1 thru BJ8 to (c)26704
	806-440	€164.88	CROSSMEMBER, rear, w/ spring hangers	1	BN1, BN2			NA	BRACKET, brake and clutch pedal	2	BN1, BN2
7	806-450	€164.88	CROSSMEMBER, rear, w/ spring hangers	1	BN4, BN6, BN7, BT7, BJ7, BJ8 to (c)26704			NA	BRACKET, brake master cylinder	1	BN1, BN2 RHD
	806-470	€184.32	CROSSMEMBER, rear, with spring hangers	1	BJ8 from (c)26705						
8	806-415	€28.08	GUSSET, rear crossmember, RH	1	all						
9	806-425	€28.08	GUSSET, rear crossmember, LH	1	BN1, BN2, BN4, BN6, BN7, BT7, BJ7						
	806-435	€28.08	GUSSET, rear crossmember, LH	1	BJ8						
	806-445	€53.04	BRACKET, rear bumper, RH	1	BN1, BN2						
	806-455	€53.04	BRACKET, rear bumper, LH	1							
10	857-660	€61.92	BRACKET, rear bumper, RH	1	BN4 thru BJ8						
12	857-670	€61.92	BRACKET, rear bumper, LH	1							
14	806-465	€47.04	BRACKET, rear spring, rear	2	BN1 - BJ8 to (c)26704						
	806-475	€36.60	BRACKET, rear spring, rear	2	BJ8 from (c)26705						
15	169800	€5.28	BUSH, shackle pin, metal	4	BN1 - BJ8 to (c)26704						
	2A5176	€1.20	BUSH, shackle pin, rubber	4	BJ8 from (c)26705						
17	856-505	€46.80	BRACKET, rear spring, front	2							
20	1B8662	€118.44	OUTRIGGER, rear, RH	1	BN1, BN2						
21	857-605	€110.04	OUTRIGGER, rear, LH	1							
	1B8662	€118.44	OUTRIGGER, rear, RH	1	BN4 thru BJ8						
	857-630	€118.44	OUTRIGGER, rear, LH	1	BN4, BN6, BN7, BT7, BJ7						
	857-650	€139.56	OUTRIGGER, rear, LH	1	BJ8						
23	857-480	NA	GUSSET, body bracket	2	BN4 thru BJ8						
24	1B8698	€93.12	OUTRIGGER, front, RH	1	all						
25	857-610	€60.12	OUTRIGGER, front, LH	1	BN1, BN2, BN4, BN6, BN7, BT7, BJ7						
	857-645	€93.12	OUTRIGGER, front, LH	1	BJ8						
28	856-061	€183.96	INNER SILL ASSY, RH, Kilmartin brand	1							
	856-060	€72.84	INNER SILL ASSY, RH	1	(2-piece assy.)						
29	856-051	€183.96	INNER SILL ASSY, LH, Kilmartin brand	1							
	856-050	€72.84	INNER SILL ASSY, LH	1							
			NA PLATFORM, engine mount, RH	1	BN1, BN2						
			NA PLATFORM, engine mount, LH	1							
30	856-445	€55.80	PLATFORM, engine mount, RH	1	BN4 thru BJ8						
32	856-455	€55.80	PLATFORM, engine mount, LH	1							
			NA REINFORCEMENT, platform	2							
36	856-480	€47.88	STRUT, RH	1							
37	856-490	€47.88	STRUT, LH	1							
38	856-475	€348.00	HOUSING, front suspension	2							
39	856-575	€18.48	BRACKET, anti-roll bar mount, RH	1							
	856-585	€18.48	BRACKET, anti-roll bar mount, LH	1							
40	856-110	€49.20	MOUNTING PLATE, RH shock	1							
41	856-120	€50.04	MOUNTING PLATE, LH shock	1							
See right hand column for adjustable shock mounts.											
	856-495	€115.08	SUPPORT, suspension housing	1							
	857-485	€41.64	BRACKET, lower link, rear, RH	1	BN1, BN2						
	857-495	€88.56	BRACKET, lower link, rear, LH	1							
43	857-490	€141.24	SUPPORT, suspension housing	1							
44	857-485	€41.64	BRACKET, lower link, rear, RH	1	BN4 thru BJ8						
	857-495	€88.56	BRACKET, lower link, rear, LH	1							
	806-325	€41.64	BRACKET, lower link, front, RH	1	BN1, BN2						
	806-335	€41.64	BRACKET, lower link, front, LH	1							
46	806-485	€41.64	BRACKET, lower link, front, RH	1	BN4 thru BJ8						
47	806-495	€41.64	BRACKET, lower link, front, LH	1							
48	806-225	NA	CUP, bumper	2							
50	806-265	€55.08	BRACKET, steering	2							
51			NA GUSSET, steering bracket	2	BN4 thru BJ8						
52	806-400	€117.60	CROSSMEMBER, front	1							
53	806-515	NA	GUSSET, front crossmember	2							
55	806-520	€644.40	CROSS BRACE ASSEMBLY	1	BN1, BN2						
55	806-525	NA	CROSS BRACE ASSEMBLY	1							
56	856-170	NA	CROSS BRACE, main beam	1	BN4, BN6, BN7, BT7, BJ7, BJ8 to (c)26704						
58	856-175	NA	HALF CROSS BRACE, front	1							
59	856-165	NA	HALF CROSS BRACE, rear	1							
	806-530	€591.60	CROSS BRACE ASSEMBLY	1	BJ8 from (c)26705						

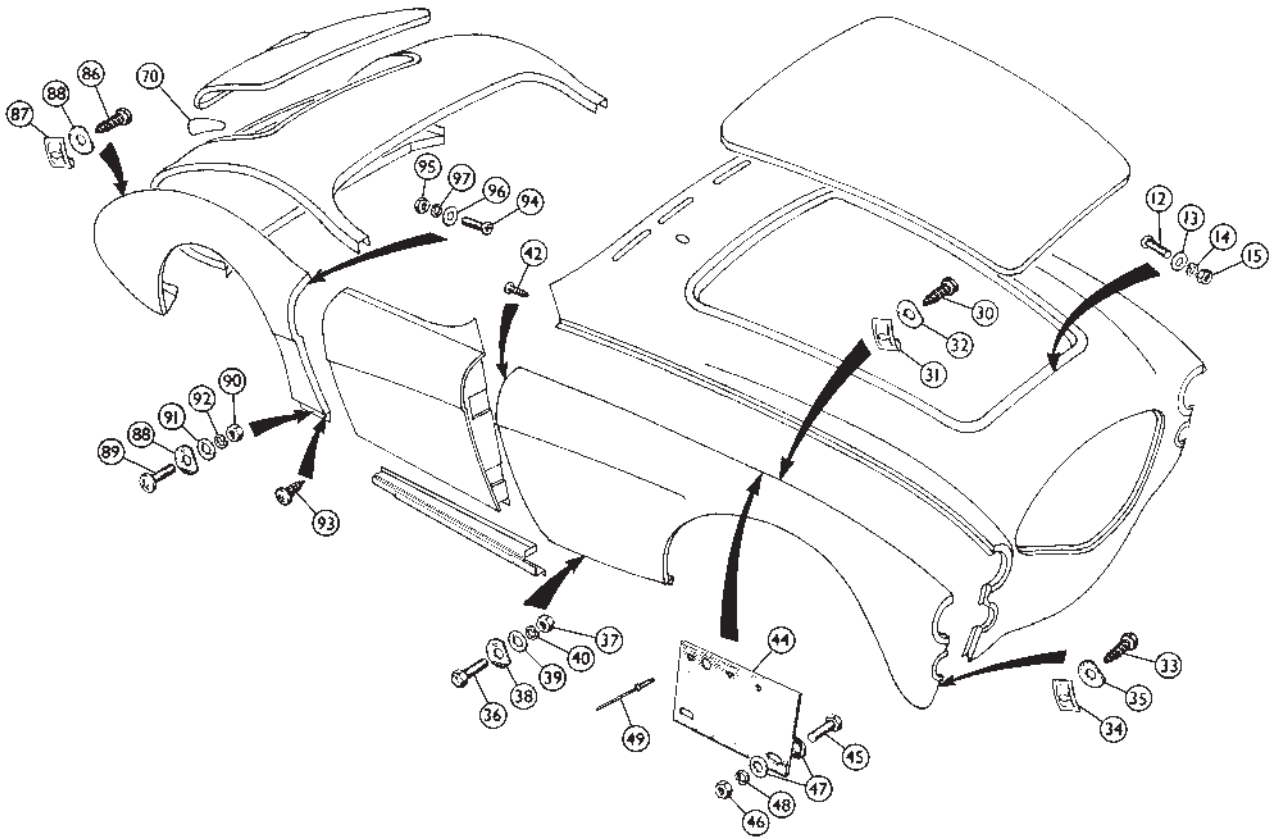
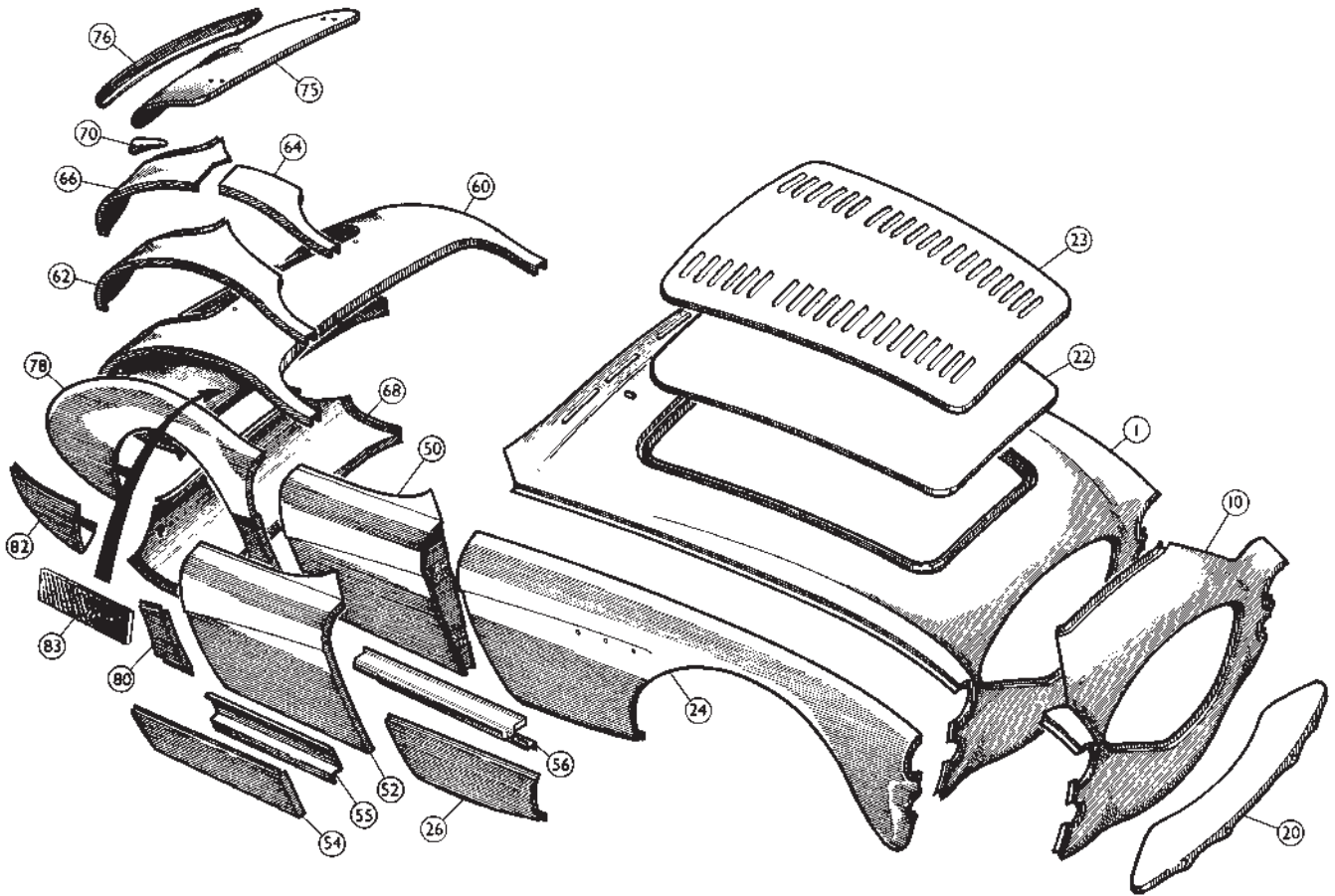

Ill.	Part Number	Price €ea.	Description	Req.	Details
Outer Body Panels 100-4					
1	858-425	NA	FRONT SHROUD ASSEMBLY	1	
10	858-435	NA	SHROUD NOSE PANEL	1	
12	CMZ308	€0.72	SCREW, shroud to crossbrace	5	
13	NA		WASHER, plain	5	
14	GHF331	€0.84	WASHER, locking	5	
15	GHF206	€1.32	NUT	5	
20	14B1909	€60.12	FRONT APRON, steel	1	
	858-130	€67.44	FRONT APRON, aluminium	1	
22	NA		BONNET ASSY, plain, steel	1	
	858-080	NA	BONNET ASSY, plain, aluminium	1	
23	858-070	€978.00	BONNET ASSY, louvred, aluminium	1	
24	NA		FRONT WING, steel, RH,	1	BN1
	NA		FRONT WING, steel, LH,	1	
	858-105	€1,548.00	FRONT WING, aluminium, RH	1	BN2
	858-115	€1,548.00	FRONT WING, aluminium, LH	1	
	858-110	€1,629.60	FRONT WING, steel, RH	1	BN2
	858-100	€1,629.60	FRONT WING, steel, LH	1	
	858-125	€1,467.60	FRONT WING, aluminium, RH	1	BN2
	858-135	€1,467.60	FRONT WING, aluminium, LH	1	
26	857-540	€211.32	FRONT WING REPAIR, RH	1	
	857-550	€211.32	FRONT WING REPAIR, LH	1	
	321-868	€12.60	FITTING KIT, front wing	2	
30	NA		BOLT, wing	14	
31	NA		NUT, spire	14	
32	NA		WASHER, 'D' shaped	14	
33	UL2705	€1.08	BOLT, wing	6	
34	NA		NUT, spire	6	
35	NA		WASHER, 'D' shaped	6	
36	GHF117	€0.72	BOLT, wing	6	
37	GHF200	€0.96	NUT	6	
38	GHF300	€1.08	WASHER, 'D' shaped	6	
39	NA		WASHER, plain	6	
40	GHF331	€0.84	WASHER, locking	6	
42	NA		SCREW, wing	14	
44	858-385	€7.44	BRACKET, front wing support	2	
45	GHF117	€0.72	SCREW, bracket	4	
46	GHF200	€0.96	NUT	4	
47	NA		WASHER, special	8	
48	GHF331	€0.84	WASHER, locking	4	
49	NA		RIVET	6	
50	NA		DOOR ASSEMBLY, bare, RH	2	BN1 to (b)5000
	NA		DOOR ASSEMBLY, bare, LH	4	
	NA		DOOR ASSEMBLY, bare, RH	4	BN1 from (b)5001, BN2
	NA		DOOR ASSEMBLY, bare, LH	8	
52	858-145	€331.20	DOOR SKIN, steel, RH	4	original material
	858-155	€331.20	DOOR SKIN, steel, LH	6	
	858-165	€331.20	DOOR SKIN, aluminium, RH	1	alternative
	858-175	€331.20	DOOR SKIN, aluminium, LH	1	
54	857-690	€57.60	REPAIR PANEL, lower, RH	1	steel
	857-680	€57.60	REPAIR PANEL, lower, LH	1	
55	858-180	€108.60	FRAME REPAIR, lower, RH	1	
	858-190	€108.60	FRAME REPAIR, lower, LH	1	
56	855-960	€41.52	SILL PANEL, RH	1	
	855-950	€41.52	SILL PANEL, LH	1	
60	858-170	NA	REAR SHROUD ASSEMBLY	1	
62	858-185	NA	REPAIR PANEL, rear shroud, side, RH	1	complete
	858-195	€462.00	REPAIR PANEL, rear shroud, side, LH	1	complete
64	858-235	€411.60	REPAIR PANEL, rear shroud, side, RH	1	upper
	858-245	€411.60	REPAIR PANEL, rear shroud, side, LH	1	upper
66	858-315	NA	REPAIR PANEL, rear shroud, side, RH	1	lower
	858-325	NA	REPAIR PANEL, rear shroud, side, LH	1	lower
68	858-255	NA	REAR SKIRT PANEL, lower	1	
70	544-690	€72.00	PLINTH, (pod), RH	1	BN2 as fitted
	544-680	€72.00	PLINTH, (pod), LH	1	
	14B3869	€7.80	PLINTH PAD	2	
	PMZ308	€0.72	SCREW, reflector plinth	6	
	NA		WASHER, locking	6	
75	NA		BOOT LID, steel	1	
	858-120	€1,304.40	BOOT LID, aluminium	1	
76	858-485	NA	BOOT LID REPAIR PANEL	1	
78	858-045	NA	REAR WING, steel, RH,	1	BN1
	858-035	NA	REAR WING, steel, LH,	1	
	858-405	€1,074.00	REAR WING, aluminium, RH	1	BN2
	858-415	€1,074.00	REAR WING, aluminium, LH	1	
	858-025	€1,119.60	REAR WING, steel, RH	1	BN2
	858-015	€1,119.60	REAR WING, steel, LH	1	
	806-760	€1,068.00	REAR WING, aluminium, RH	1	BN2
	806-770	€1,068.00	REAR WING, aluminium, LH	1	
80	857-510	€88.08	REAR WING REPAIR, front, RH	1	
	857-511	€142.08	REAR WING REPAIR, front, RH, premium	1	
	857-500	€88.08	REAR WING REPAIR, front, LH	1	
	857-501	€131.88	REAR WING REPAIR, front, LH, premium	1	
82	857-515	€253.20	REAR WING REPAIR, rear, RH	1	
	857-525	€253.20	REAR WING REPAIR, rear, LH	1	
83	NA		TAPPED PLATE	2	
	321-818	€18.84	FITTING KIT, rear wing	2	
86	NA		BOLT, wing	14	
87	NA		NUT, spire	14	

Ill.	Part Number	Price €ea.	Description	Req.	Details
	88	NA	WASHER, 'D' shaped	18	
	89	SE910201	€1.08 SCREW	4	
	90	GHF206	€1.32 NUT	4	
	91	NA	WASHER, plain	8	
	92	GHF331	€0.84 WASHER, locking	4	
	93	AB608051	€0.84 SCREW	2	
	94	CMZ308	€0.72 SCREW	16	
	95	GHF206	€1.32 NUT	16	
	96	PWZ203	€0.96 WASHER, plain	16	
	97	GHF331	€0.84 WASHER, locking	16	
	858-205	€97.32	ANTI-CORROSION JOINT STRIP	1	sufficient for 1 car

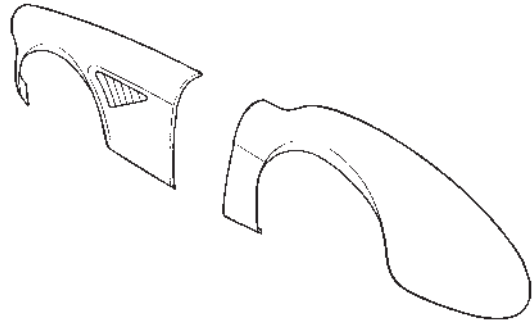

806-836	€416.40	VENT PAIR, alloy, for front wings	1	(w/outer flanges)
806-835	€343.20	VENT PAIR, alloy, for front wings	1	(no flanges)
806-860	€1,149.60	REAR WING, RH w/ small flare†	1	BN2
806-870	€1,149.60	REAR WING, LH, w/ small flare†	1	
806-880	€1,231.20	REAR WING, RH, w/ large flare•	1	
806-890	€1,231.20	REAR WING, LH, w/ large flare•	1	

† 1/2" flare
• 1" flare

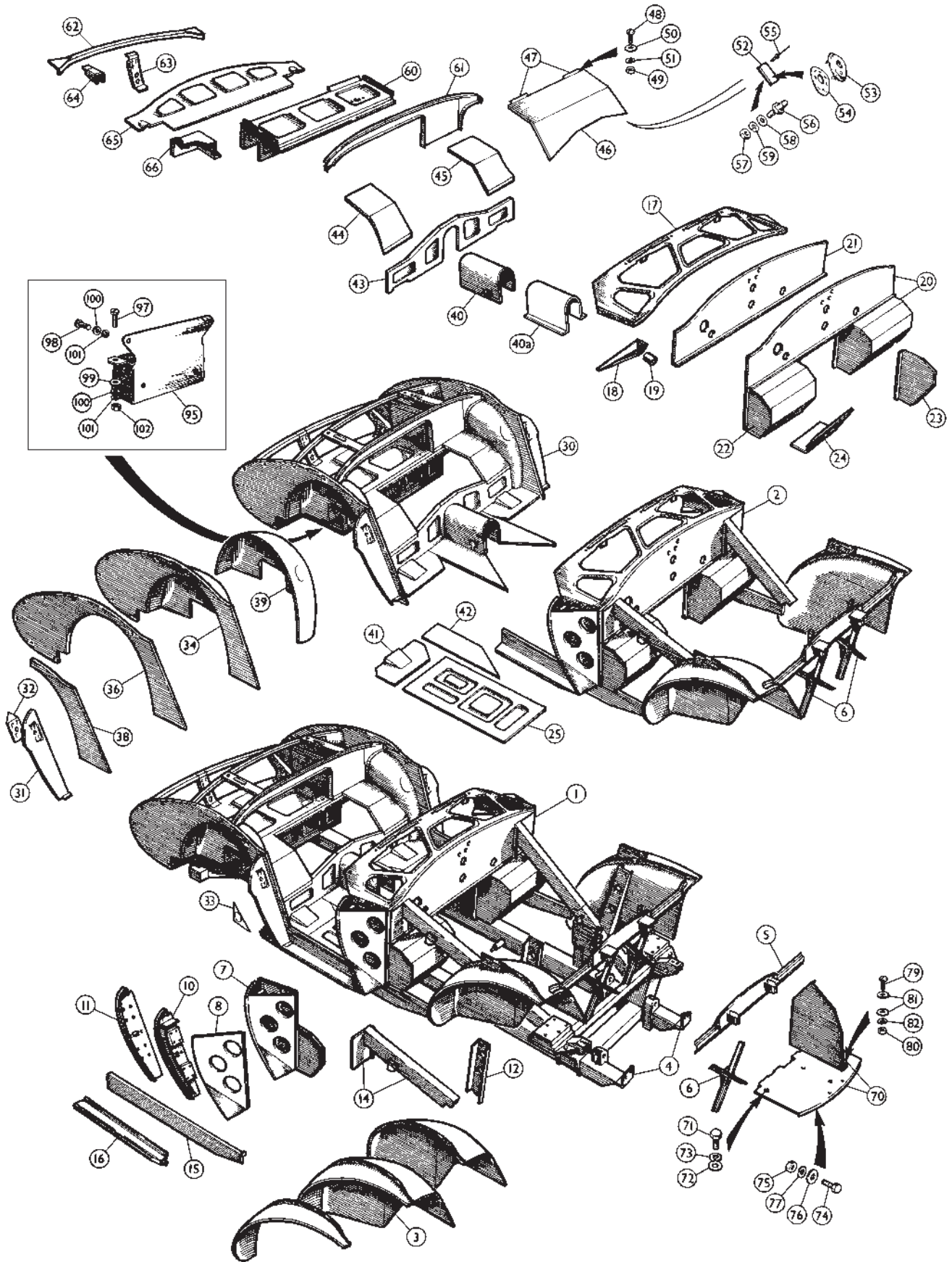

Ill.	Part Number	Price €ea.	Description	Req.	Details	Ill.	Part Number	Price €ea.	Description	Req.	Details
Inner Body Panels 100-4											
1	NA		CHASSIS FRAME ASSEMBLY, includes front & rear assemblies	1	BN1 to (b)1952	53	552650	€1.32	FASTENER, 'Lift-the-Dot', female	2	
	NA		CHASSIS FRAME ASSEMBLY, includes front & rear assemblies	1	BN1 from (b)1953 to 5000	54	552651	€1.44	PLATE, fastener	2	
	NA		CHASSIS FRAME ASSEMBLY, includes front & rear assemblies	1	BN1 from (b)5001, BN2	55			NA RIVET	6	
2	NA		FRONT END ASSEMBLY	1	BN1 to (b)1952	56	97H717	€1.80	STUD, 'Lift-the-Dot'	2	
	NA		FRONT END ASSEMBLY	1	BN1 from (b)1953 to 5000	57	GHF206	€1.32	NUT	2	
	NA		FRONT END ASSEMBLY	1	BN1 from (b)5001, BN2	58	GHF306	€0.72	WASHER, plain	2	
3	806-300	€800.40	WHEEL ARCH ASSEMBLY, RH	1		59	GHF331	€0.84	WASHER, locking	2	
	806-310	€800.40	WHEEL ARCH ASSEMBLY, LH	1		60	858-625	€279.60	COVER, bulkhead over main axle	1	
4	858-585	€6.84	BRACKET, shroud, RH	1		61			NA COCKPIT PANEL, rear bulkhead	1	
	858-595	€12.48	BRACKET, shroud, LH	1		62	806-665	€135.36	REAR SKIRT RAIL ASSEMBLY	1	
5	806-346	€152.16	BONNET HINGE & CROSS BRACE ASSY	1	with hinge brackets	63	806-680	€26.04	SUPPORT, rear skirt rail	1	
	806-345	€192.24	BONNET HINGE & CROSS BRACE ASSY	1	without hinge brackets	64	806-690	€17.16	SUPPORT, bumper bracket to rear skirt	1	RH
6	806-395	€78.72	CROSS BRACE ASSEMBLY	1	(pair)	65	806-695	€17.16	SUPPORT, bumper bracket to rear skirt	1	LH
7	NA		SCUTTLE SIDE PANEL ASSY., RH	1	BN1 to (b)5000	66	856-321	€91.44	INNER BOOT BOX REPAIR, RH	1	Early BN1
	NA		SCUTTLE SIDE PANEL ASSY., LH	1			856-320	€91.44	INNER BOOT BOX REPAIR, RH	1	Late BN1, BN2
	806-240		NA SCUTTLE SIDE PANEL ASSY., RH	1	BN1 from (b)5001, BN2		856-326		NA INNER BOOT BOX REPAIR, LH	1	Early BN1
	806-535		NA SCUTTLE SIDE PANEL ASSY., LH	1			856-325	€91.44	INNER BOOT BOX REPAIR, LH	1	Late BN1, BN2
	806-250		NA SCUTTLE SIDE PANEL ASSY., LH	1	BN2 from (b)10031	70	SC3042	€141.48	APRON PANEL SET (2 pieces)	1	
8	806-375	€112.92	SIDE REINFORCEMENT, RH	1		71	GHF117	€0.72	BOLT, panel to chassis	4	
	806-385	€112.92	SIDE REINFORCEMENT, LH	1		72	GHF300	€1.08	WASHER, plain	4	
10	806-540	€267.60	HINGE PILLAR ASSY, RH	1	BN1 to (b)5000	73	GHF331	€0.84	WASHER, locking	4	
	806-550	€267.60	HINGE PILLAR ASSY, LH	1		74	SH604041	€0.84	BOLT, apron to cowl	2	
	806-130	€161.52	HINGE PILLAR ASSY, RH	1		75	GHF206	€1.32	NUT	2	
	806-160	€161.52	HINGE PILLAR ASSY, LH	1	BN1 from (b)5001, BN2	76	GHF300	€1.08	WASHER, plain	2	
11	806-545	€136.20	HINGE PILLAR REPAIR, RH	1		77	GHF331	€0.84	WASHER, locking	2	
	806-555	€136.20	HINGE PILLAR REPAIR, LH	1		79	PMZ308	€0.72	SCREW	3	
12	806-570	€33.00	CHANNEL, inner guard to shroud support channel	1	RH	80	GHF206	€1.32	NUT	3	
	806-580	€33.00	CHANNEL, inner guard to shroud support channel	1	LH	81	GHF306	€0.72	WASHER, plain	6	
14	807-135	€104.04	BULKHEAD SUPPORT ASSY., RH	1		82	GHF331	€0.84	WASHER, locking	3	
	807-145	€104.04	BULKHEAD SUPPORT ASSY., LH	1		95	806-190	€55.68	BUMP STOP BOX, spiral bevel axle	2	BN1 to C.E.221535
15	856-060	€72.84	INNER SILL ASSY, RH	1	(2-piece assy.)		SC40	€25.44	BUMP STOP BOX, hypoid axle	2	BN1 from C.E.221536, BN2
	856-050	€72.84	INNER SILL ASSY, LH	1		97			NA BOLT, box to body	4	
	856-060A	€33.96	INNER SILL ASSY, R/H	A/R		98	SH604041	€0.84	SCREW, box to wheelarch	4	
	856-060B	€33.96	INNER SILL ASSY, intermediate R/H	A/R	(1-piece assy.)	99	WM57	€1.20	WASHER, plain, large	4	
	856-050A	€33.96	INNER SILL ASSY, L/H	A/R		100	GHF300	€1.08	WASHER, plain, small	8	
	856-050B	€33.96	INNER SILL ASSY, intermediate L/H	A/R		101	GHF331	€0.84	WASHER, locking	8	
16	855-960	€41.52	SILL PANEL, RH	1		102	GHF200	€0.96	NUT	4	
	855-950	€41.52	SILL PANEL, LH	1							
17	856-075	€1,231.20	SCUTTLE TOP PANEL	1							
18	NA		DEMISTER BOX, RH	1							
	NA		DEMISTER BOX, LH	1							
19	NA		TUBE, demister box	2							
20	NA		BULKHEAD AND PEDAL BOX ASSY	1							
21	806-560	€95.64	BULKHEAD REPAIR PANEL	1							
22	806-805	€162.48	OUTER SIDE PANEL, RH	1							
	806-825	€165.72	OUTER SIDE PANEL, LH	1							
23	806-565	€53.40	INNER SIDE PANEL, RH	1							
	806-575	€53.40	INNER SIDE PANEL, LH	1							
24	806-135	€80.76	TOEBOARD REPAIR, RH	1							
	806-145	€80.76	TOEBOARD REPAIR, LH	1							
25	855-945	€40.32	FLOOR PANEL, RH	1							
	855-955	€40.32	FLOOR PANEL, LH	1							
30	NA		REAR END ASSEMBLY	1	BN1 to (b)2235						
	NA		REAR END ASSEMBLY	1	BN1 from (b)2236, BN2						
31	806-585		NA SHUT PILLAR ASSEMBLY, RH	1	BN1 to (b)2235						
	806-595		NA SHUT PILLAR ASSEMBLY, LH	1							
	806-045	€50.04	SHUT PILLAR ASSEMBLY, RH	1	BN1 from (b)2236, BN2						
	806-055	€50.04	SHUT PILLAR ASSEMBLY, LH	1							
32	806-605	€43.20	TRIANGLE BOX, shut pillar	2							
33	806-615	€30.24	GUSSET, pillar to sill, RH	1							
	806-625	€30.24	GUSSET, pillar to sill, LH	1							
34	NA		INNER PANEL & WHEELARCH ASSY	1	RH						
	NA		INNER PANEL & WHEELARCH ASSY	1	LH						
36	AHB8955	€142.92	INNER QUARTER PANEL, RH	1							
	806-230	€147.12	INNER QUARTER PANEL, LH	1							
38	858-605	€73.44	REPAIR PANEL, front, RH	1							
	858-615	€73.44	REPAIR PANEL, front, LH	1							
39	806-610	€538.80	REAR WHEEL ARCH, RH	1							
	806-620	€538.80	REAR WHEEL ARCH, LH	1							
40	806-630	€72.00	DRIVESHAFT TUNNEL, rear	1							
40a	858-635	€85.20	DRIVESHAFT TUNNEL, front	1	BN1						
41	806-635	€18.84	FLOOR PANEL, rear, RH	1							
	806-645	€18.84	FLOOR PANEL, rear, LH	1							
42	806-650	€18.72	FLOOR PANEL, centre	2							
43	806-660	€163.20	HEELBOARD, rear, full width	1							
44	806-675	€83.76	AXLE COVER PANEL, RH	1							
45	806-685	€83.76	AXLE COVER PANEL, LH	1							
46	806-600	€174.48	BATTERY ACCESS COVER	1							
47	NA		HINGE	2							
48	NA		SCREW, hinge to panel	4							
49	GHF206	€1.32	NUT	4							
50	GHF306	€0.72	WASHER, plain	4							
51	GHF331	€0.84	WASHER, locking	4							
52	NA		STRAP, battery access panel	2							

iii. Part Number Price €ea. Description Req. Details

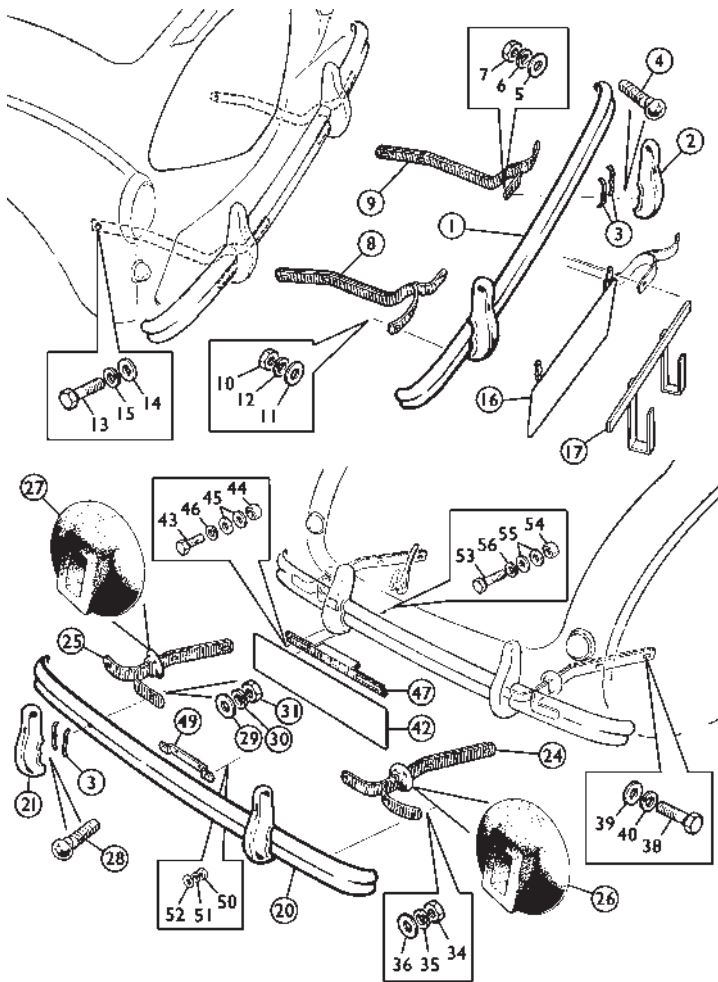

Bumpers 100-4

1	854-260	€406.80	BUMPER BAR, front	1	
2	27H9612	€101.52	OVERRIDER, front, with bolt	2	
3	37H9871M	€3.36	SEAL, overrider, per metre	1	
4	SH606101	€1.08	BOLT, overrider mounting	2	
5	GHF303	€0.72	WASHER, plain	2	
6	GHF334	€1.32	WASHER, locking	2	
7	GHF203	€0.72	NUT, overrider bolt	2	
8	804-270	€48.36	BUMPER BRACKET, front, RH	1	
9	804-260	€29.64	BUMPER BRACKET, front, LH	1	
10	GHF202	€0.72	NUT, bumper to bracket	4	
11	GHF303	€0.72	WASHER, plain	4	
12	GHF333	€0.72	WASHER, locking	4	
13	BH606161	€1.32	BOLT, spring bar to chassis	4	
14	GHF300	€1.08	WASHER, plain	4	
15	GHF333	€0.72	WASHER, locking	4	
16	806-390	€42.48	SUPPORT, front number plate	1	UK style
17	806-730	€85.20	BRACKET, mounting, number plate	1	N. American style
20	854-270	€416.40	BUMPER BAR, rear	1	
21	27H9612	€101.52	OVERRIDER, rear	2	
24	804-300	€45.72	BUMPER BRACKET, rear, RH	1	
25	804-310	€45.72	BUMPER BRACKET, rear, LH	1	
26	1A9307	€8.64	GROMMET, spring bar, RH	1	
27	1A9308	€8.64	GROMMET, spring bar, LH	1	
28	NA		BOLT, rear overrider mounting	2	original overriders
29	GHF303	€0.72	WASHER, plain	2	
30	GHF334	€1.32	WASHER, locking	2	
31	GHF203	€0.72	NUT, overrider bolt	2	
34	GHF202	€0.72	NUT, bumper to bracket	2	
35	GHF303	€0.72	WASHER, plain	2	
36	GHF333	€0.72	WASHER, locking	2	
38	BH606161	€1.32	BOLT, bumper bracket to chassis	4	
39	WP9	€2.04	WASHER, plain	4	
40	GHF333	€0.72	WASHER, locking	4	
42	451-715	€32.76	SUPPORT, rear number plate	1	UK only
43	SH604041	€0.84	BOLT, support to bracket	2	
44	GHF200	€0.96	NUT	2	
45	WM57	€1.20	WASHER, plain	2	
46	GHF331	€0.84	WASHER, locking	2	
47	806-360	€15.00	BRACKET, rear number plate	1	
49	806-355	€11.76	BRACKET, number plate lamp	1	
50	GHF200	€0.96	NUT, bracket to bumper bar	2	
51	GHF300	€1.08	WASHER, plain	4	
52	GHF331	€0.84	WASHER, locking	2	
53	SH604051	€0.72	BOLT, bracket to body	2	
54	GHF200	€0.96	NUT	2	
55	GHF300	€1.08	WASHER, plain	4	
56	GHF331	€0.84	WASHER, locking	2	

iii. Part Number Price €ea. Description Req. Details

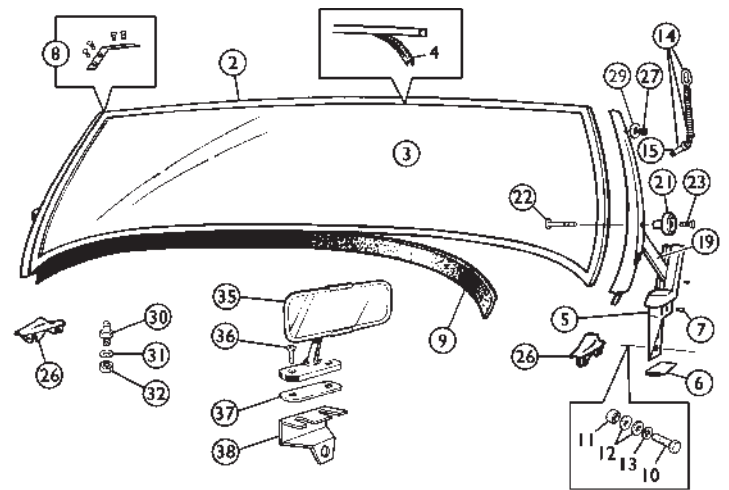

Windscreen 100-4

	NA		WINDSCREEN ASSEMBLY	1	
2	NA		FRAME ASSEMBLY, windscreen	1	
3	14B18620E	€444.00	GLASS, windscreen, Triplex brand	1	
4	14B1862	€253.20	GLASS, windscreen	1	
4	SC250	€20.40	GLAZING RUBBER	1	
5	806-715	€698.40	STANCHION AND FOOT, RH	1	
	806-720	€698.40	STANCHION AND FOOT, LH	1	
6	NA		PACKING PLATE	2	
7	NA		SCREW	8	
8	805-050	€26.88	BRACKET KIT, windscreen frame	1	with screws
9	280-725	€43.20	SEAL, windscreen, bottom	1	
10	NA		SCREW, frame to scuttle	4	
11	GHF200	€0.96	NUT	4	
12	GHF300	€1.08	WASHER, plain	8	
13	GHF331	€0.84	WASHER, locking	4	
14	805-150	€20.40	SECURITY SPRING ASSEMBLY	2	
15	NA		PIN, shouldered	2	
19	021-954	€49.80	LINK	2	
21	805-240	€16.68	KNURLED KNOB	2	
22	806-655	€21.36	BOLT, shouldered, with screw #22	2	
23	806-710	€21.36	SCREW, for knob	2	

Note: Original type screws #806-710 have left hand threads. Screws supplied with bolt #22 have right hand threads.

26	805-247	€56.76	FOOT, forward windscreen position	2	
27	021-953	€23.28	KNOB, soft top clamp	2	
	NA		SCREW	2	
29	806-700	€3.36	WASHER	2	
30	97H717	€1.80	FASTENER, 'Lift-the-Dot', in dash	2	
31	NA		WASHER, plain	2	
32	GHF206	€1.32	NUT	2	
35	14B1867	€28.08	MIRROR, driving	1	
36	AJD2246	€1.32	SCREW	2	
37	NA		TAPPED PLATE	1	
38	805-825	€16.80	CENTRE BRACKET, dash/driving mirror	1	

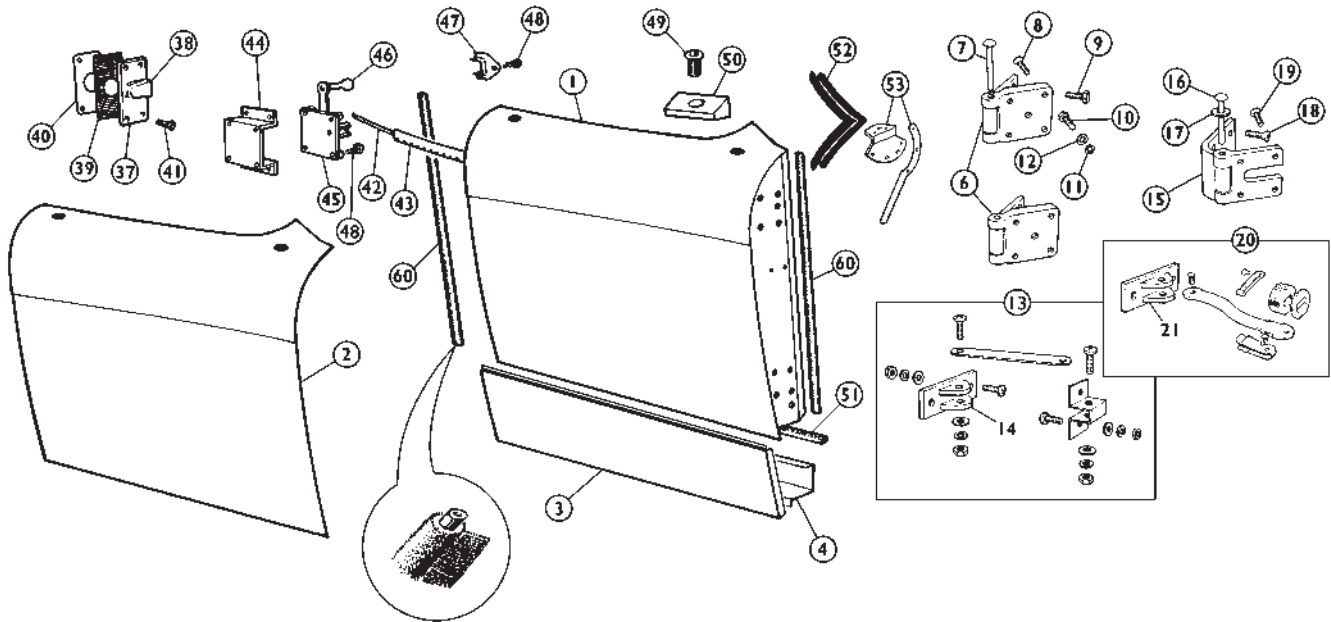

iii. Part Number Price €ea. Description

Doors and Door Fittings 100-4

Part Number	Price €ea.	Description	Req.	Details
1		NA DOOR ASSEMBLY, bare, RH	1	BN1 to (b)5000
		NA DOOR ASSEMBLY, bare, LH	1	
		NA DOOR ASSEMBLY, bare, RH	1	BN1 from (b)5001, BN2
		NA DOOR ASSEMBLY, bare, LH	1	
2	858-145 €331.20	DOOR SKIN, steel, RH	1	original material
	858-155 €331.20	DOOR SKIN, steel, LH	1	
	858-165 €331.20	DOOR SKIN, aluminium, RH	1	alternative
	858-175 €331.20	DOOR SKIN, aluminium, LH	1	
3	857-690 €57.60	SKIN REPAIR, lower, RH	1	steel
	857-680 €57.60	SKIN REPAIR, lower, LH	1	
4	858-180 €108.60	FRAME REPAIR, lower, RH	1	
	858-190 €108.60	FRAME REPAIR, lower, LH	1	
6	806-740 €218.88	DOOR HINGE PAIR, RH	1	
	806-750 €218.88	DOOR HINGE PAIR, LH	1	
7		NA HINGE PIN	4	
8	SF605081 €1.08	SCREW, hinge to door, 1"	12	
	SF605061 €1.68	SCREW, hinge to door, 3/4"	4	
9	SF605081 €1.08	SCREW, hinge to body, 1"	16	BN1 to (b)5000
10	GHF101 €0.72	BOLT, hinge to body, 1"	4	
11	GHF300 €1.08	WASHER, plain	4	
12	GHF332 €0.84	WASHER, locking	4	
13	806-800 NA	DOOR CHECK ASSEMBLY, RH	1	
	806-810 NA	DOOR CHECK ASSEMBLY, LH	1	
14	806-815 €8.40	SHOE, chromed	2	
15	806-780 €166.56	DOOR HINGE	4	
16		NA HINGE PIN	4	
17		NA WASHER, hinge pin	16	
18	SF605081 €1.08	SCREW, hinge to door, 1"	8	BN1 from (b)5001, BN2
	SF605061 €1.68	SCREW, hinge to door, 3/4"	8	
19	SF605081 €1.08	SCREW, hinge to body, 1"	16	
20	806-745 €72.00	DOOR CHECK ASSEMBLY	2	
21	806-815 €8.40	SHOE, check strap, chromed	2	
37	806-755 NA	STRIKER ASSEMBLY, door lock	2	
38	401-093 €23.76	STRIKER	2	BN1 to (b)2235
39		NA PLATE, packing	2	
		NA PLATE, tapped	2	
37	612856 €49.44	STRIKER ASSEMBLY, door lock	2	
38	401-093 €23.76	STRIKER	2	BN1 from (b)2236, BN2
39	805-195 €5.16	PLATE, packing	2	
40	805-155 €21.24	PLATE, tapped	2	
41	RMP316 €1.32	SCREW	8	
42	14B1938 €20.40	CABLE	2	
43	806-795 NA	COVERING, black	2	
44	031-435 €49.92	BRACKET, lock mounting, RH	1	
	031-445 €28.80	BRACKET, lock mounting, LH	1	
45	803-785 €69.72	DOOR LOCK ASSEMBLY, RH	1	
	803-775 €69.72	DOOR LOCK ASSEMBLY, LH	1	
46	803-795 €25.56	KNOB, door lock	2	
47	14B2544 €7.92	ESCUTCHEON, lock catch	2	
48	54K3024 €0.96	SCREW, chromed	8	
	725-176 NA	SCREW, stainless steel	8	alternate option4
49	805-170 €13.44	SOCKET, side screen	4	
50	805-168 €18.00	WOODEN BLOCK PAIR, securing windscreen socket, (pair)	2	
51	682-285 NA	SEALING RUBBER, bottom of door	2	BN1, BN2

iii. Part Number Price €ea. Description

682-295 NA SEALING RUBBER, door to scuttle 2 BN1, BN2 to (b)11142

Note: The later seals (listed below) may be used by cutting off the "U" channel along the edge of the scuttle where it meets the straight portion of the door, and using the late bracket set.

52	806-785	€48.36	SEAL SET, door to scuttle (2 pieces)	1	BN2 from (b)11143
53	805-185	€33.96	BRACKET SET, scuttle seal	1	
60	552877BLK	€18.96	DRAUGHT EXCLUDER, furflex, black	A/R	sold per meter
	552877RED	€18.96	DRAUGHT EXCLUDER, furflex, red	A/R	
	552877BLU	€18.96	DRAUGHT EXCLUDER, furflex, blue	A/R	
	249-820	NA	DRAUGHT EXCLUDER, furflex, green	A/R	
	249-790	NA	DRAUGHT EXCLUDER, furflex, beige	A/R	

Rear edge of door panel: 3" above latch, 16" below latch
 Front edge of door panel: 21.5"
 Back edge of kick panel: 21"

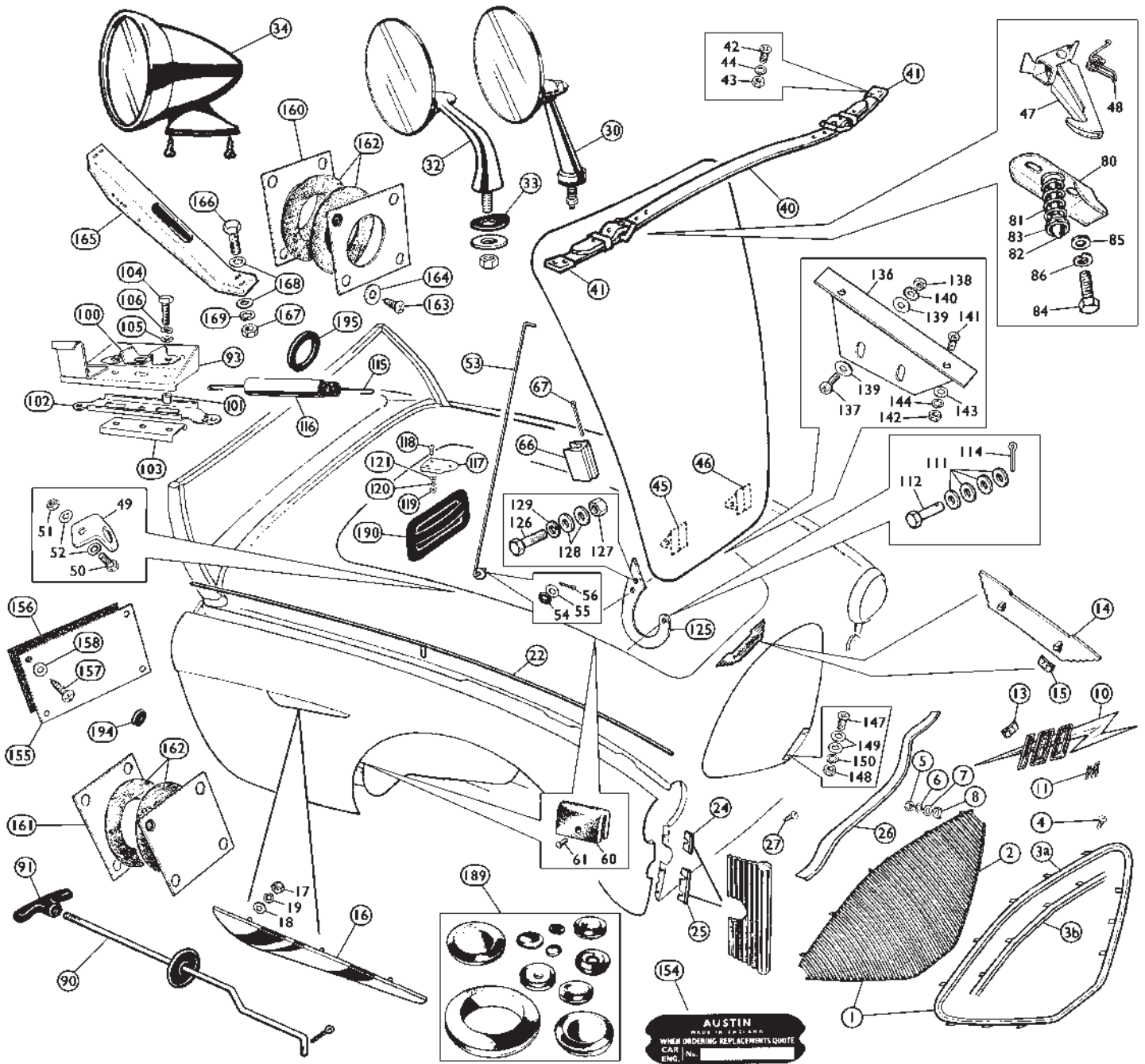

ill.	Part Number	Price €ea.	Description	Req.	Details
Front Body Fittings 100-4					
Radiator Grille					
1		NA	GRILLE ASSEMBLY, radiator	1	incl. #2,3,4
2	870-050	€1,044.00	GRILLE, radiator	1	
3a	870-080	€489.60	SURROUND, radiator grille	1	round arch
3b	870-081	NA	SURROUND, radiator grille (detail)	1	flat top

Grille surrounds from the factory had either a rounded arch at the top, or two distinct angles with a flat area between. These two may be safely interchanged. A few of the earliest cars had a single angle apex at the top centre.

4	AB606021	€0.84	SCREW, self-tapping	12	
5	GHF206	€1.32	NUT	5	
6	GHF331	€0.84	WASHER, locking	5	
7	GHF306	€0.72	WASHER, plain	5	
8	325-760	€4.80	U CLIPS	5	
10	14B1724	€18.24	MOTIF, 100	1	standard 100-4
11	021-742	€36.60	MOTIF, "M" with attaching wires	1	100M
13	326-510	€0.96	SPIRE NUT	2	
14	14B1723	€101.52	BADGE, Austin Healey wings	1	
15	ADB509	€0.84	SPIRE NUT	2	

Front Wing Fittings

16	14B1727	€17.16	FLASH, RH	1	} premium quality
	14B1728	€17.16	FLASH, LH	1	
17	GHF206	€1.32	NUT	6	
18	GHF306	€0.72	WASHER, plain	6	
19	GHF331	€0.84	WASHER, locking	6	
20		NA	BEADING, front wing, short	1	} original fitment no longer supplied; use item #22
21		NA	BEADING, front wing, long	1	
22	14B6729	€32.76	BEADING, front wing, full length	2	} orig. type N/A later type supplied
24	14B6824	€0.84	BEADING, upper wing joint, plastic	2	
25	14B6825	€0.96	BEADING, lower wing joint, plastic	2	
26	021-748	€6.84	PIPING, front apron	1	
27		NA	SCREW, apron to cowl & wings	8	
28		NA	PLUG, bottom, front apron	2	
30	165-270	NA	MIRROR, boomerang type	2	} period style
32	WM1906	€24.24	MIRROR, RH, flat glass	1	
	WM1907	€24.24	MIRROR, LH, flat glass	1	} Lucas style
	WM1904	€24.24	MIRROR, RH, convex glass	1	
	WM1905	€24.24	MIRROR, LH, convex glass	1	
	33	280-140	€3.60	PAD, mirror stem	
34	222-372	€61.20	MIRROR, flat glass	A/R	} racing style
		NA	MIRROR, convex glass	A/R	

Bonnet Fittings

40	221-608	€256.80	BONNET STRAP, safety	1	} 100M; will fit all 100-4
41	221-598	€21.72	FIXING PLATE SET, bonnet strap	1	
42		NA	SCREW	4	
43	GHF206	€1.32	NUT	4	
44	GHF331	€0.84	WASHER, locking	4	
45	021-744	NA	HINGE BRACKET, bonnet, RH	1	
46	021-745	NA	HINGE BRACKET, bonnet, LH	1	
47	14A366	€18.72	HOOK ASSEMBLY, bonnet	1	
48	4B8646	€4.08	SPRING	1	
49	802-555	€17.88	BRACKET, pivot, bonnet prop rod	1	
50	CMZ308	€0.72	SCREW, bracket	2	
51	GHF206	€1.32	NUT	2	
52	GHF306	€0.72	WASHER, plain	2	
53	804-550	€44.52	ROD, bonnet prop	1	
54	682-200	€0.84	GROMMET, rubber	1	
55	GHF301	€0.60	WASHER, plain	1	
56		NA	SPLIT PIN	1	
60	14B766	€1.56	BUFFER, rubber	A/R	
61	325-765	€1.32	RIVET, buffer to bonnet surround	A/R	
	325-770	€0.72	WASHER, copper (for no. 61)	A/R	
66	2H9215	€2.40	CLIP, rubber, bonnet prop rod	1	
67	GHF504	€1.08	SPLIT PIN	1	
69	SH604041	€0.84	SCREW, bracket to crossbrace	2	
70	GHF331	€0.84	WASHER, locking	2	
71	GHF300	€1.08	WASHER, plain	2	
72	GHF200	€0.96	NUT	2	
75	SH604041	€0.84	SCREW	2	
76	GHF331	€0.84	WASHER, locking	2	
77	GHF300	€1.08	WASHER, plain	2	
78	GHF200	€0.96	NUT	2	
		NA	STRIKER PIN ASSEMBLY, bonnet catch 1	1	} BN1 to (b)1949
		NA	SPRING, striker pin	1	
		NA	STRIKER PIN ASSEMBLY, bonnet catch 1	1	
80					} BN1 from (b)1950, BN2
81	FPQ10001	€3.72	SPRING, striker pin	1	
82	14A6586	€10.56	STRIKER PIN	1	
83	ADA458	€15.48	CUP	1	
84	SH604051	€0.72	BOLT, striker pin assembly	2	
85	GHF300	€1.08	WASHER, plain	2	
86	GHF331	€0.84	WASHER, locking	2	
90	805-595	NA	ROD, bonnet lock	1	
91	805-505	NA	KNOB, bonnet lock rod	1	
93	805-545	€67.80	SUPPORT, bonnet latch	1	
95	SE910201	€1.08	SCREW, bracket to bulkhead panel	3	
96	GHF206	€1.32	NUT	3	
97	GHF306	€0.72	WASHER, plain	6	

ill.	Part Number	Price €ea.	Description	Req.	Details
98	GHF331	€0.84	WASHER, locking	3	
100	AAM1223	€8.28	PLATE, guide	1	
101	ADA464	€2.76	TUBE, distance	2	
102	ADA461	€46.68	SLIDER, bonnet catch	1	
103	ADH456	€28.80	SLIDER SUPPORT ASSY	1	
104		NA	SCREW, plate	2	
105	GHF300	€1.08	WASHER, plain	2	
106	GHF331	€0.84	WASHER, locking	2	
107		NA	LEVER	1	
108	SE910201	€1.08	SCREW, lever to slider	3	
109	GHF206	€1.32	NUT	3	
110	GHF306	€0.72	WASHER, plain	6	
111	GHF331	€0.84	WASHER, locking	3	
112		NA	CLEVIS PIN	1	
114	GHF500	€1.08	SPLIT PIN	1	
115	ADA466	€9.12	SPRING, tension, bonnet catch	1	
116	ADA467	€2.52	SLEEVE, spring	1	
117	805-515	€15.00	RETAINER, tension spring	1	
118	CMZ308	€0.72	SCREW	2	
119	GHF206	€1.32	NUT	2	
120	GHF331	€0.84	WASHER, locking	2	
121	GHF306	€0.72	WASHER, plain	2	
	805-535	€64.68	HINGE, bonnet	2	
125	805-525	€23.76	ARM, bonnet hinge	2	
126	SH604041	€0.84	BOLT, hinge to bonnet	4	
127	GHF200	€0.96	NUT	4	
128	GHF300	€1.08	WASHER, plain	4	
129	GHF331	€0.84	WASHER, locking	4	

Shroud Panel Supports

	805-355	€10.80	BRACKET, shroud to upright, RH	1	
136	805-365	€16.68	BRACKET, shroud to upright, LH	1	not 100-M
	805-375	€19.80	BRACKET, shroud to upright, LH	1	100-M
137	PMZ308	€0.72	SCREW, bracket to upright	4	
138	GHF206	€1.32	NUT	4	
139	GHF306	€0.72	WASHER, plain	8	
140	GHF331	€0.84	WASHER, locking	4	
141	CMZ308	€0.72	SCREW, bracket to shroud	4	
142	GHF206	€1.32	NUT	4	
143	GHF306	€0.72	WASHER, plain	4	
144	GHF331	€0.84	WASHER, locking	4	
147	PMZ308	€0.72	SCREW, bracket to shroud and radiator lower cowl panel	4	
148	GHF206	€1.32	NUT	4	
149	GHF306	€0.72	WASHER, plain	8	
150	GHF331	€0.84	WASHER, locking	4	

Plates and Plugs

		NA	PLATE, chassis ID (on chassis rail)	1	BN1 prior to (c)219000
154	CRCP313	€9.48	PLATE, chassis ID	1	from BN1 (c)219000
155		NA	PLATE, blanking pedal hole	1	
156		NA	FELT	1	
157		NA	SCREW	2	
158		NA	WASHER, plain	2	
160		NA	PLATE, steering column sealing, inner 2	2	
161		NA	PLATE, steering column blanking, inner 2	2	
162	805-455	NA	FELT, sealing and blanking plates	4	
163	AB606031	€0.84	SCREW, plate	16	
164		NA	WASHER, special	16	
165		NA	BRACKET, steering column	1	
166	SH605051	€1.80	SCREW, bracket	4	
167	GHF201	€0.84	NUT	4	
168	GHF301	€0.60	WASHER, plain	8	
169	GHF332	€0.84	WASHER, locking	4	
170		NA	PLATE, blanking heater tube holes	2	
171	PMZ307	€1.20	SCREW	2	
172	GHF206	€1.32	NUT	2	
173	GHF331	€0.84	WASHER, locking	2	
174		NA	PLATE, blanking dipper switch hole	1	
175		NA	FELT	1	
176	SE910201	€1.08	SCREW	2	
177	GHF206	€1.32	NUT	2	
178	GHF331	€0.84	WASHER, locking	2	
179	GHF306	€0.72	WASHER, plain	2	
180		NA	COVER, brake master cylinder	1	
189	681-018	€22.08	GROMMET AND PLUG SET, bulkhead	1	general assortment
	4G4920	€3.48	PLUG, cold air duct in dash	2	
		NA	PLUG, blanking fixing hole for brake fluid reservoir, RHD	2	
	4G4920	€3.48	PLUG, cold air duct	1	
		NA	PLUG, bulkhead heater access	1	
194	RFN403	€1.80	GROMMET, heater cable	1	
195	3H2506	€2.64	GROMMET, bulkhead, steering column	2	

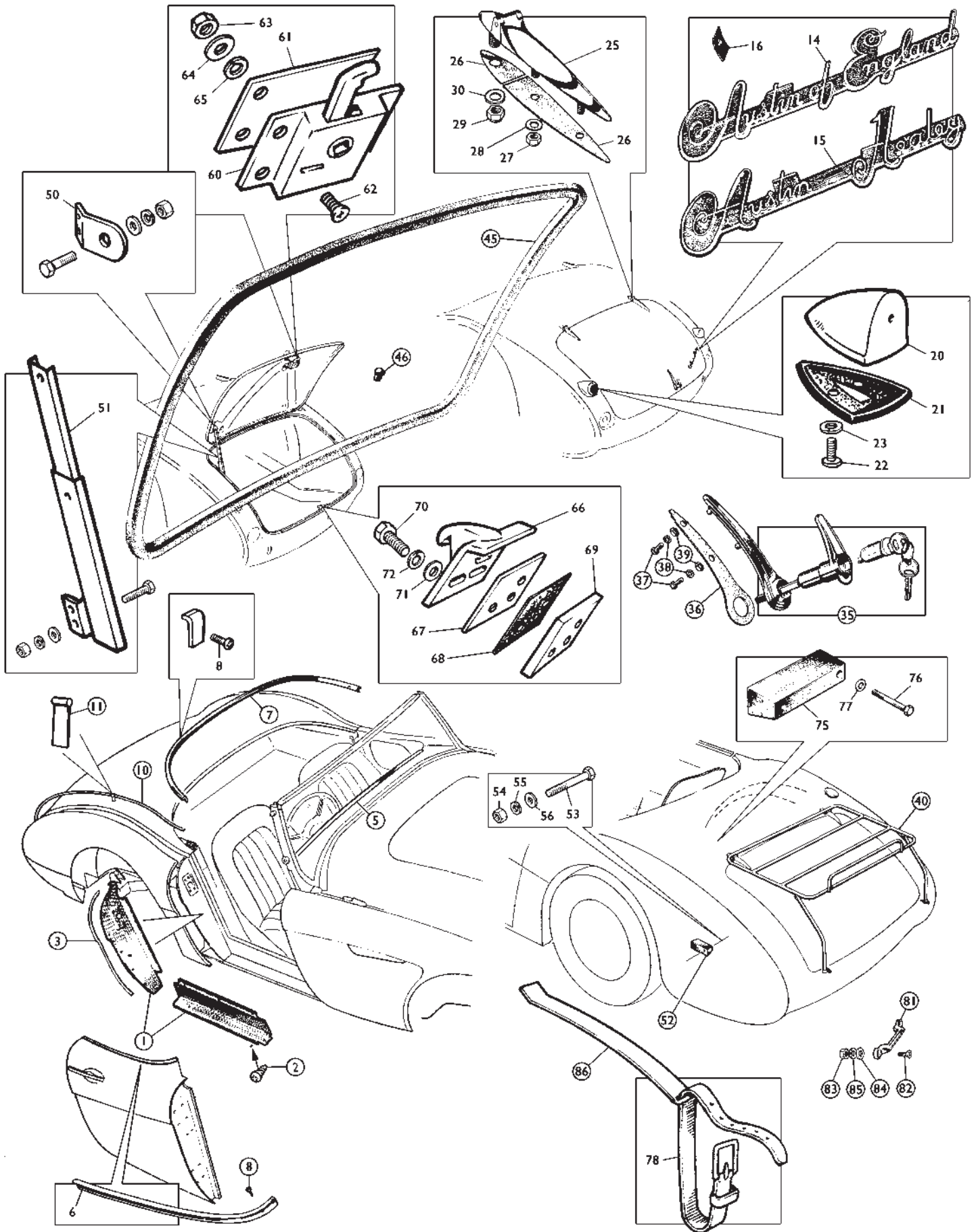

ill.	Part Number	Price €ea.	Description	Req.	Details
Rear Body Fittings 100-4					
Cockpit Fittings					
	802-955	NA	FINISHER SET, door shut face, RH	1	} BN1 to (b)2235
	802-965	NA	FINISHER SET, door shut face, LH	1	
1	MM803-800	€78.60	FINISHER SET, door shut face, RH	1	} BN1 from (b)2236, BN2
	MM803-810	€78.60	FINISHER SET, door shut face, LH	1	
2	54K3024	€0.96	SCREW, chromed	A/R	} alternate option
	725-176	NA	SCREW, stainless steel	A/R	
3	249-880	€14.40	PIPPING, shut pillar finisher, black	1	} 6 foot length for 2 doors
	249-886	€8.28	PIPPING, shut pillar finisher, red	1	
	249-896	€11.04	PIPPING, shut pillar finisher, blue	1	
		NA	PIPPING, shut pillar finisher, green	1	
5	804-900	€122.64	MOULDING, scuttle	1	
6	804-920	€88.92	MOULDING, door cockpit, RH	1	
	804-930	€88.92	MOULDING, door cockpit, LH	1	
7	804-910	€151.32	MOULDING, rear cockpit	1	
8	725-180	€0.84	SCREW, moulding attaching	22	

*These mouldings are supplied polished and slightly over-length. They must be trimmed to fit your particular car, and may be clear anodized locally.

Rear External Fittings

10	14B1708	€48.36	BEADING, rear wing	2	
11		NA	TAB, piping to rear wing	16	
14	4B6932	€32.04	BADGE, 'Austin of England'	1	early BN1
15	8G705	€18.12	BADGE, 'Austin Healey'	1	
16	PFS106	€0.72	FIXING, badge	3	
20	544-690	€72.00	PLINTH, (pod), RH	1	} BN2 as fitted
	544-680	€72.00	PLINTH, (pod), LH	1	
21	14B3869	€7.80	PLINTH PAD	2	
22	PMZ308	€0.72	SCREW, reflector plinth	6	
23	GHF331	€0.84	WASHER, locking	6	
25	14B1726	€67.80	BOOT HINGE, LH	1	
	14B1725	€67.80	BOOT HINGE, RH	1	
26	14B3462K	€5.40	GASKET SET, boot hinge	1	car set
27	GHF271	€0.84	NUT, hinge to boot lid	4	
28	GHF300	€1.08	WASHER, plain	4	
29	GHF272	€1.20	NUT, hinge to body	2	
30	GHF301	€0.60	WASHER, plain	2	
35	14B1963	€67.80	HANDLE, boot lid, with lock & two keys	1	
36	14B1964	€1.80	GASKET, boot handle	1	
37	PMZ306	€1.08	SCREW	2	
38	WL700101	€1.20	WASHER, shakeproof	2	
39		NA	WASHER, cup	2	
40	644-710	NA	LUGGAGE RACK	1	

Trunk Internal Fittings

45	SC208	€32.16	BOOT LID SEAL (glues into channel on boot lid, with the larger rounded edge to the outside)	1	
46	4G8595	€1.80	BUFFER, boot lid	3	
50		NA	STAY BRACKET	1	
51	804-530	€37.92	STAY, boot lid	1	
52		NA	BLOCK, packing	1	
53		NA	SCREW, to wheelarch	2	
54	GHF200	€0.96	NUT	2	
55		NA	WASHER, locking	2	
56	GHF300	€1.08	WASHER, plain, 1/4"	2	
57		NA	WASHER, plain, 9/32"	2	
60	14B1718	€71.16	LOCK	1	
61		NA	PACKING PLATE	1	
62	SF604061	€0.96	SCREW, fixing lock	4	
63	GHF200	€0.96	NUT	4	
64	GHF300	€1.08	WASHER, plain	4	
65	GHF331	€0.84	WASHER, locking	4	
66	14B1719	€50.52	STRIKER, boot lid	1	
67	806-885	NA	PLATE, packing	A/R	
68	807-005	NA	PACKING PIECE	1	
69		NA	PLATE, tapped	1	
70		NA	SCREW, striker	3	
71	GHF300	€1.08	WASHER, plain	3	
72	GHF331	€0.84	WASHER, locking	3	
75	221-680	NA	BLOCK, spare wheel	1	
76		NA	SCREW, block to rear wheel arch	2	
77		NA	WASHER, plain	2	
78	221-645	€117.12	STRAP ASSY, spare tyre	1	
81	2K9579	€7.56	STAPLE, chrome, strap retaining	1	
82		NA	SCREW, staple to axle cover panel	2	
83	GHF206	€1.32	NUT	2	
84		NA	WASHER, plain	2	
85	GHF331	€0.84	WASHER, locking	2	
86	221-655	€32.16	RETAINING BAR, spare tyre	1	

ill.	Part Number	Price €ea.	Description	Req.	Details
------	-------------	------------	-------------	------	---------

ill.	Part Number	Price €ea.	Description	Req.	Details
Outer Body Panels 100-6, 3000					
1	4B1085	€5,792.40	FRONT SHROUD ASSEMBLY	1	BN4, BN6, BN7, BT7
	858-915	NA	FRONT SHROUD ASSEMBLY	1	BJ7, BJ8 to (b)76137
	858-925	NA	FRONT SHROUD ASSEMBLY	1	BJ8 from (b)76138
2	858-935	NA	SHROUD NOSE PANEL	1	BN4, BN6, BN7, BT7, BJ7,
3	857-535	€538.80	FRONT LOWER REPAIR	1	BJ8 to (b)76137
	858-945	NA	SHROUD NOSE PANEL	1	BJ8 from (b)76138
	857-545	€538.80	FRONT LOWER REPAIR	1	
4	857-575	€326.40	FRONT UPPER REPAIR	1	
5	857-555	€408.00	FRONT UPPER QTR., RH	1	
6	857-565	€408.00	FRONT UPPER QTR., LH	1	
7		NA	SCUTTLE TOP, outer panel	1	BN4, BN6, BN7, BT7
		NA	SCUTTLE TOP, outer panel	1	BJ7, BJ8
8	857-585	€661.20	SHROUD SIDE REPAIR, RH	1	
9	857-595	€661.20	SHROUD SIDE REPAIR, LH	1	
12	CMZ305	€1.20	SCREW, shroud to crossbrace	3	
13		NA	WASHER, plain	3	
14	GHF331	€0.84	WASHER, locking	3	
15	GHF206	€1.32	NUT	3	
16	14B5735	€65.64	FRONT APRON PANEL, steel	1	original material
	021-749	€68.16	FRONT APRON PANEL, aluminium	1	alternative
20	856-145	€1,353.60	BONNET ASSY, aluminium, ribbed	1	BN4, BN6 as fitted
21	858-090	NA	BONNET ASSY, steel, plain	1	
	858-140	€1,231.20	BONNET ASSY, aluminium, plain	1	BN6, BN7, BT7, BJ7, BJ8
	021-751	€1,117.20	BONNET ASSY, aluminium, louvred	1	
24	AHB9442	€1,304.40	FRONT WING, RH, steel	1	original material
	AHB9443	€1,304.40	FRONT WING, LH, steel	1	
	858-055	€1,206.00	FRONT WING, RH, aluminium	1	alternative
	858-065	€1,206.00	FRONT WING, LH, aluminium	1	
26	857-560	€211.32	WING REPAIR, steel, RH	1	
	857-570	€211.32	WING REPAIR, steel, LH	1	
28	321-868	€12.60	FITTING KIT, front wing	2	
44	858-385	€7.44	BRACKET, front wing support	2	
45	GHF117	€0.72	BOLT, bracket	4	
46	GHF200	€0.96	NUT	4	
47		NA	WASHER, special	8	
48	GHF331	€0.84	WASHER, locking	4	
49		NA	RIVET	6	
50	856-205	NA	DOOR ASSEMBLY, bare, steel, RH	1	
	856-215	NA	DOOR ASSEMBLY, bare, steel, LH	1	
	858-075	€1,018.80	DOOR ASSEMBLY, bare, aluminium, RH	1	
	858-085	€1,018.80	DOOR ASSEMBLY, bare, aluminium, LH	1	
51	856-225	€620.40	DOOR SKIN, steel, RH	1	BN4, BN6, BN7, BT7
	856-235	€620.40	DOOR SKIN, steel, LH	1	
	856-640	€620.40	DOOR SKIN, aluminium, RH	1	
	856-650	€620.40	DOOR SKIN, aluminium, LH	1	
52	857-580	€66.96	SKIN REPAIR, lower, steel, RH	1	
	857-590	€66.96	SKIN REPAIR, lower, steel, LH	1	
53	856-635	€44.16	REPAIR, lower frame, steel, RH	1	
	856-645	€44.16	REPAIR, lower frame, steel, LH	1	
50	856-245	NA	DOOR ASSEMBLY, bare, steel, RH	1	
	856-255	NA	DOOR ASSEMBLY, bare, steel, LH	1	
51	856-660	€408.00	DOOR SKIN, steel, RH	1	
	856-670	€408.00	DOOR SKIN, steel, LH	1	
		NA	DOOR SKIN, aluminium, RH	1	BJ7
		NA	DOOR SKIN, aluminium, LH	1	
52	857-580	€66.96	SKIN REPAIR, lower, steel, RH	1	
	857-590	€66.96	SKIN REPAIR, lower, steel, LH	1	
53		NA	FRAME REPAIR, lower, RH	1	
		NA	FRAME REPAIR, lower, LH	1	
50	856-620	NA	DOOR ASSEMBLY, bare, steel, RH	1	BJ8 to (c)26704
	856-630	NA	DOOR ASSEMBLY, bare, steel, LH	1	
	856-375	NA	DOOR ASSEMBLY, bare, steel, RH	1	BJ8 from (c)26705
	856-385	NA	DOOR ASSEMBLY, bare, steel, LH	1	
51	856-615	NA	DOOR SKIN, steel, RH	1	
	856-625	NA	DOOR SKIN, steel, LH	1	
		NA	DOOR SKIN, aluminium, RH	1	
		NA	DOOR SKIN, aluminium, LH	1	BJ8
52	857-580	€66.96	SKIN REPAIR, lower, steel, RH	1	
	857-590	€66.96	SKIN REPAIR, lower, steel, LH	1	
53	856-655	€83.16	FRAME REPAIR, lower, RH	1	
	856-665	€83.16	FRAME REPAIR, lower, LH	1	
56	14B5749	€46.80	SILL PANEL, RH	1	
	14B5750	€46.80	SILL PANEL, LH	1	
58	858-445	NA	REAR SHROUD ASSEMBLY	1	BN4, BT7
	858-455	NA	REAR SHROUD ASSEMBLY	1	BJ7, BJ8 to (b)76137
	858-475	NA	REAR SHROUD ASSEMBLY	1	BJ8 from (b)76138
60	858-495	NA	REAR SHROUD ASSEMBLY	1	BN6, BN7
61	857-710	€489.60	REAR SKIRT PANEL	1	
66	858-545	€462.00	SHROUD SIDE REPAIR, RH	1	BN4, BN6, BN7, BT7, BJ7,
	858-555	€462.00	SHROUD SIDE REPAIR, LH	1	BJ8 to (b)76137
	858-565	€462.00	SHROUD SIDE REPAIR, RH	1	BJ8 from (b)76138
	858-575	€462.00	SHROUD SIDE REPAIR, LH	1	
75	858-020	€1,393.20	BOOT LID, steel	1	original material
	858-005	€1,328.40	BOOT LID, aluminium	1	alternative
76	805-715	€191.64	BOOT LID REPAIR, steel	1	
80	858-025	€1,119.60	REAR WING, RH, steel	1	original material
	858-015	€1,119.60	REAR WING, LH, steel	1	
	806-760	€1,068.00	REAR WING, RH, aluminium	1	alternative
	806-770	€1,068.00	REAR WING, LH, aluminium	1	
82	857-510	€88.08	WING REPAIR, front section, steel	1	RH
	857-511	€142.08	WING REPAIR, front section, steel	1	RH, premium
	857-500	€88.08	WING REPAIR, front section, steel	1	LH
	857-501	€131.88	WING REPAIR, front section, steel	1	LH, premium

ill.	Part Number	Price €ea.	Description	Req.	Details	
	84	857-515	€253.20	WING REPAIR, rear section, steel	1	RH
		857-525	€253.20	WING REPAIR, rear section, steel	1	LH
	85	321-818	€18.84	FITTING KIT, rear wing	2	
	86	857-505	NA	PLATE, tapped	2	
		858-205	€97.32	ANTI-CORROSION JOINT STRIP	1	sufficient for 1 car

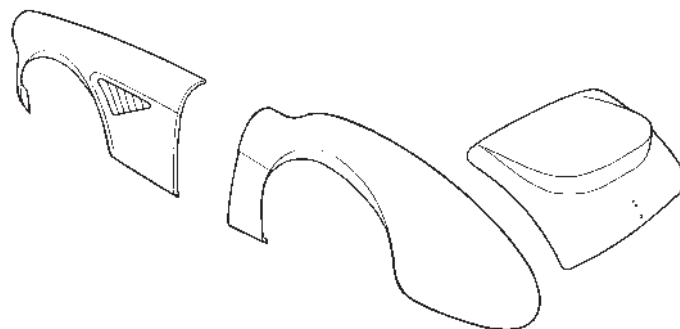

Alloy Competition Body Parts

Great quality reproductions of aluminium alloy body panels similar to those fitted to the Works prepared race and rally cars can now be yours. (Works cars did not have flared wings.) Pick the ones which best suit your race or rally car. Works Healeys did not use flared wings with their 165x15 tyres on 4.5" wheels. Flares are required for use with 185x15" tyres on 72-spoke wire wheels. Professional fitting of these wings is advised.

All wings below marked T must be shipped by truck freight.

806-865	€1,515.60	FRONT WING, R/H, with vents	1] BN4 - BJ8
806-875	€1,515.60	FRONT WING, L/H, with vents	1	
806-820	€1,564.80	FRONT WING, R/H, flared*	1	
806-830	€1,564.80	FRONT WING, L/H, flared*	1	
806-840	€1,760.40	FRONT WING, R/H, flared w/ vents*	1] (w/outer flanges)
806-850	€1,760.40	FRONT WING, L/H, flared w/ vents*	1	
806-836	€416.40	VENT PAIR, alloy, for front wings	1] (without flanges)
806-835	€343.20	VENT PAIR, alloy, for front wings	1	
806-860	€1,149.60	REAR WING, R/H w/ small flare†	1] BN2 - BJ8
806-870	€1,149.60	REAR WING, L/H, w/ small flare†	1	
806-880	€1,231.20	REAR WING, R/H, w/ large flare•	1] BN4 - BJ8
806-890	€1,231.20	REAR WING, L/H, w/ large flare•	1	
806-895	€2,208.00	BOOT LID, works type	1	
021-751	€1,117.20	BONNET, louvred	1	

* 1-1/2" flare † 1/2" flare • 1" flare

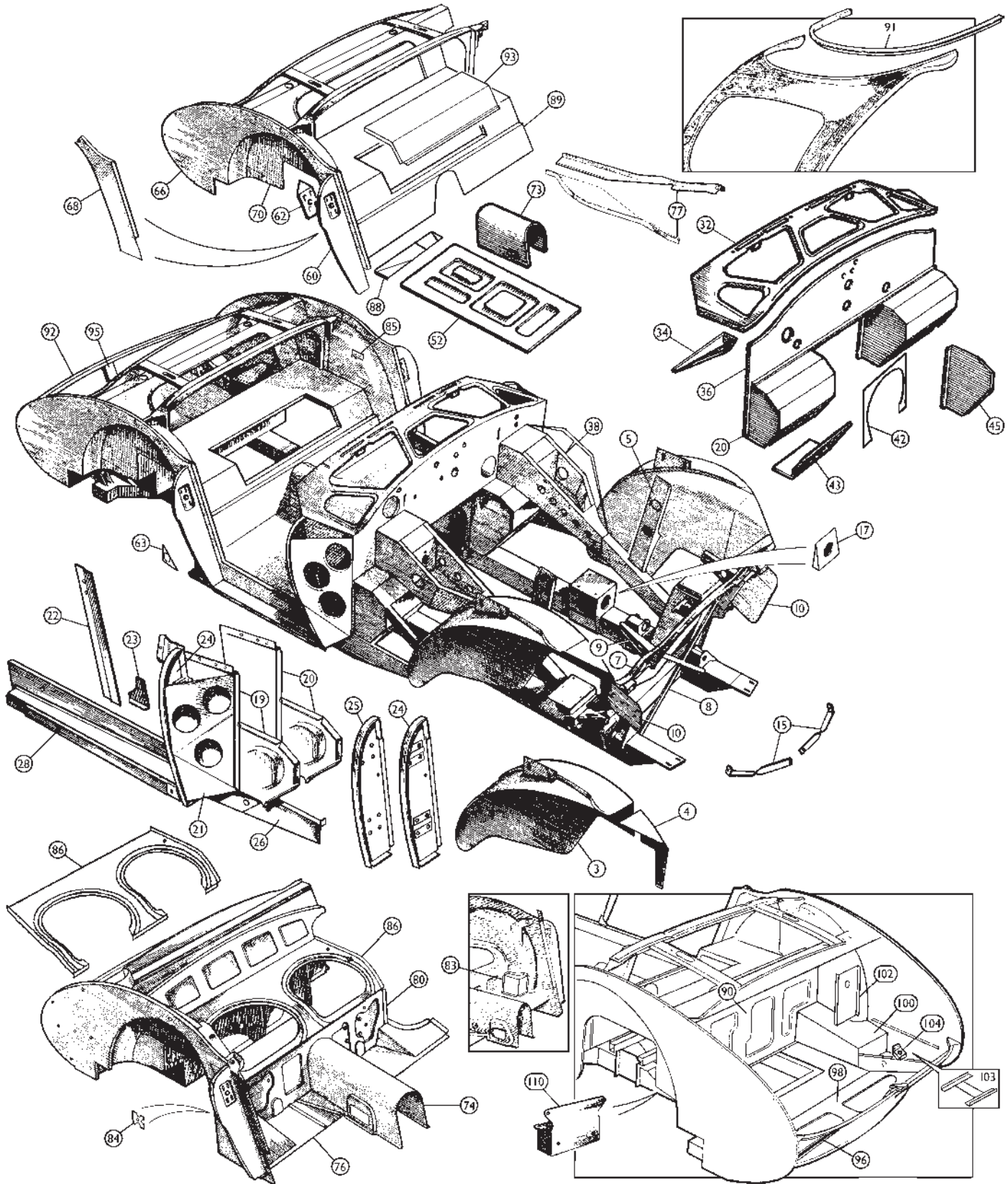

Ill.	Part Number	Price €ea.	Description	Req.	Details
------	-------------	------------	-------------	------	---------

Inner Body Panels 100-6, 3000

Complete chassis frames changed many times over the years. The listing below will help identify which ones are interchangeable.

	856-530	NA	CHASSIS FRAME ASSEMBLY	1	BN4, BT7
	856-540	NA	CHASSIS FRAME ASSEMBLY	1	BN6, BN7
	856-550	NA	CHASSIS FRAME ASSEMBLY	1	BJ7
	856-560	NA	CHASSIS FRAME ASSEMBLY	1	BJ8 to (c)26704
	856-570	NA	CHASSIS FRAME ASSEMBLY	1	BJ8 from (c)26705
3	806-300	€878.40	WHEEL ARCH, steel, RH	1	original material
	806-310	€800.40	WHEEL ARCH, steel, LH	1	
	856-525	NA	WHEEL ARCH, aluminium, RH	1	alternative
	856-535	NA	WHEEL ARCH, aluminium, LH	1	
4	856-555	€39.96	EXTENSION, inner guard, RH	1	
	856-565	€39.96	EXTENSION, inner guard, LH	1	
5	856-675	€33.12	CHANNEL, shroud support, RH	1	
	856-685	€33.12	CHANNEL, shroud support, LH	1	
7	856-485	€97.32	CROSS BRACE UPPER PANEL	1	
8	856-590	€50.76	CROSS BRACE ASSY	1	
9	856-695	€77.64	BRACKET SET, radiator steady	1	
10	806-320	€158.40	SPLASH PANEL SET, with stays	1	
11		NA	SCREW	2	
12	GHF206	€1.32	NUT	2	
13		NA	WASHER, plain	2	
14	GHF331	€0.84	WASHER, locking	2	
15	856-180	€14.16	STEADY BRACKET PAIR w/hardware	1	BN7, BT7
17	021-374	€58.92	REINFORCING SET, engine mounts (set of 4)	1	BN4-BJ8
19	806-260	€446.40	SCUTTLE SIDE ASSY, RH	1	BN4, BN6, BN7, BT7
	806-270	NA	SCUTTLE SIDE ASSY, LH	1	
	806-280	NA	SCUTTLE SIDE ASSY, RH	1	BJ7, BJ8
	806-290	NA	SCUTTLE SIDE ASSY, LH	1	
20	805-685	€159.00	FOOTWELL SIDE PANEL, RH	1	BN4, BN6, BN7, BT7
	805-695	€159.00	FOOTWELL SIDE PANEL, LH	1	
	805-735	€188.64	FOOTWELL SIDE PANEL, RH	1	BJ7, BJ8
	805-745	€159.96	FOOTWELL SIDE PANEL, LH	1	
21	805-605	€122.52	SIDE REINFORCEMENT, RH	1	BN4, BN6, BN7, BT7
	805-615	€115.44	SIDE REINFORCEMENT, LH	1	
	805-635	€95.64	SIDE REINFORCEMENT, RH	1	BJ7, BJ8
	805-645	€95.64	SIDE REINFORCEMENT, LH	1	
22		NA	EXTENSION PLATE, side, RH	1	BN4 from C.E.68960,
		NA	EXTENSION PLATE, side, LH	1	BN6, BN7, BT7, BJ7, BJ8
23		NA	GUSSET PLATE, side to sill	2	
24	806-140	€142.92	HINGE PILLAR ASSY, RH	1	
	806-170	€142.92	HINGE PILLAR ASSY, LH	1	BN4, BN6, BN7, BT7
25	806-235	€110.04	HINGE PILLAR REPAIR, RH	1	
	806-245	€96.48	HINGE PILLAR REPAIR, LH	1	
	806-150	€151.32	HINGE PILLAR ASSY, RH	1	BJ7, BJ8
	806-275	€102.48	HINGE PILLAR REPAIR, RH	1	
	806-285	€102.48	HINGE PILLAR REPAIR, LH	1	
26	856-061	€183.96	INNER SILL ASSY, RH, Kilmartin brand	1	
	856-060	€72.84	INNER SILL ASSY, RH	1	2-piece assy
	856-051	€183.96	INNER SILL ASSY, LH, Kilmartin brand	1	
	856-050	€72.84	INNER SILL ASSY, LH	1	
26	856-060A	€33.96	INNER SILL ASSY, RH	A/R	
	856-060B	€33.96	INNER SILL ASSY, intermediate RH	A/R	1-piece assy
	856-050A	NA	INNER SILL ASSY, LH	A/R	
	856-050B	€33.96	INNER SILL ASSY, intermediate LH	A/R	
28	14B5749	€46.80	SILL PANEL, RH	1	
	14B5750	€46.80	SILL PANEL, LH	1	
32	856-071	€1,027.20	SCUTTLE TOP INNER PANEL	1	BN4, BN6, BN7, BT7
		NA	SCUTTLE TOP INNER PANEL	1	BJ7
	856-072	€1,434.00	SCUTTLE TOP INNER PANEL	1	BJ8
34		NA	DEMISTER CHANNEL ASSEMBLY	1	BN4, BN6, BN7, BT7
36		NA	BULKHEAD REPAIR	1	
		NA	BULKHEAD REPAIR	1	BJ7
		NA	BULKHEAD REPAIR	1	BJ8
38	805-800	€98.16	PEDAL BOX ASSEMBLY, RH	1	BN4 thru BJ8
	805-810	€98.16	PEDAL BOX ASSEMBLY, LH	1	BN4 thru BJ7
	805-812	€98.16	PEDAL BOX ASSEMBLY, LH	1	BJ8
42	807-125	€150.48	REINFORCEMENT PANEL	1	BN4, BN6, BN7 to (c)16038, BT7 to (c)15880
	807-120	€188.88	REINFORCEMENT PANEL	1	BN7, BT7 from above, BJ7, BJ8
43	856-035	€28.80	TOE BOARD, front floor, RH	1	BN4, BN6, BN7, BT7
	856-036	€55.44	TOE BOARD, front floor, RH	1	BJ7, BJ8 (w/brake booster)
	856-025	€28.80	TOE BOARD, front floor, LH	1	BN4 thru BJ8
45		NA	INNER SIDE PANEL, RH	1	BN4, BN6, BN7, BT7
		NA	INNER SIDE PANEL, LH	1	
		NA	INNER SIDE PANEL, RH	1	BJ7, BJ8
		NA	INNER SIDE PANEL, LH	1	
49		NA	REINFORCEMENT, side panel	1	BN6, BN7 to (c)16038
		NA	REINFORCEMENT, side panel	1	BN7 from (c)16039, BT7 from (c)15881, BJ7, BJ8
50		NA	SEALING FLANGE, tunnel, RH	1	
		NA	SEALING FLANGE, tunnel, LH	1	
52	807-130	€202.80	FLOOR PANEL, RH	1	BN4, BN6
	807-140	€202.80	FLOOR PANEL, LH	1	
	856-030	€40.32	FLOOR PANEL, RH	1	BN7, BT7, BJ7, BJ8
	856-020	€40.32	FLOOR PANEL, LH	1	
59		NA	REAR END ASSEMBLY	1	
60	AHB5392	€45.36	SHUT PILLAR ASSEMBLY, RH	1	BN4, BN6, BN7, BT7
	AHB5393	€45.36	SHUT PILLAR ASSEMBLY, LH	1	
	8G9156	€40.68	SHUT PILLAR ASSEMBLY, RH	1	BJ7, BJ8

Ill.	Part Number	Price €ea.	Description	Req.	Details
	8G9157	€40.68	SHUT PILLAR ASSEMBLY, LH	1	
62	806-605	€43.20	TRIANGLE BOX, pillar	2	BN4, BN6, BN7, BT7
	806-434	€27.24	TRIANGLE BOX, pillar	2	BJ7, BJ8
63	806-615	€30.24	GUSSET, pillar to sill, RH	1	
	806-625	€30.24	GUSSET, pillar to sill, LH	1	
66	806-035	NA	REAR QUARTER, steel, RH	1	original material
	AHB8956	€142.92	REAR QUARTER, steel, LH	1	
		NA	REAR QUARTER, aluminium, RH	1	alternative
		NA	REAR QUARTER, aluminium, LH	1	
68	856-765	€83.76	REPAIR PANEL, rear wing, front, steel, RH	1	
	856-775	€83.76	REPAIR PANEL, rear wing, front, steel, LH	1	
70	806-305	€571.20	WHEEL ARCH, steel, RH	1	original material
	806-315	€571.20	WHEEL ARCH, steel, LH	1	
		NA	DRIVESHAFT TUNNEL, rear	1	BN4
73		NA	DRIVESHAFT TUNNEL, rear	1	BN6, BN7
74	805-775	€72.00	DRIVESHAFT TUNNEL, rear	1	BT7, BJ7, BJ8
76	856-350	€65.28	FLOOR SECTION, rear, RH	1	BN4, BT7, BJ7, BJ8 to (c)26704
	856-355	€65.28	FLOOR SECTION, rear, LH	1	
	856-300	€99.00	FLOOR SECTION, rear, RH	1	BJ8 from (c)26705
	856-305	€101.52	FLOOR SECTION, rear, LH	1	
77	805-785	€157.20	EDGE KIT, gearbox cover	1	BN7 from (c)16039, BT7 from (c)15881, BJ7, BJ8 to (c)26704
80	856-340	€61.92	HEELBOARD, rear, RH	1	BN4, BT7, BJ7, BJ8 to (c)26704
	856-345	€61.92	HEELBOARD, rear, LH	1	
	856-482	€238.68	HEELBOARD, complete	1	
	856-312	€139.80	HEELBOARD repair, centre sect.	1	
	856-310	€78.72	HEELBOARD repair, RH side	1	
	856-315	€78.72	HEELBOARD repair, LH side	1	BJ8 from (c)26705
83	856-595	€83.76	BOX AND GUSSET, radius arm, RH	1	
	856-605	€83.76	BOX AND GUSSET, radius arm, LH	1	
84	856-745	€78.72	MOUNTING, radius arm, RH	1	
	856-755	€78.72	MOUNTING, radius arm, LH	1	
85	805-755	€27.36	SEAT BELT MOUNTING, rear	2	BT7, BJ7, BJ8 to mid '67
86	805-820	€360.00	SURROUND PANEL, rear seat	1	BN4, BT7, BJ7, BJ8 (Seat bottom panel only. Does not include vertical rear panel.)
88	807-155	€39.96	FLOOR PANEL, rear, RH	1	
	807-165	€39.96	FLOOR PANEL, rear, LH	1	BN6, BN7
89	805-790	€223.92	HEELBOARD, rear, full width	1	
90	805-795	€143.76	REAR BULKHEAD	1	BN4, BT7, BJ7, BJ8
91	806-215	€658.80	DRAINAGE CHANNEL	1	BJ7, BJ8
92	805-725	€114.24	REAR SKIRT RAIL ASSEMBLY	1	
93	807-055	€177.48	COVER, battery access	1	BN6, BN7
95	806-680	€26.04	SUPPORT, trunk skirt rail	1	
96	806-155	€45.48	SUPPORT, trunk lip, RH	1	
	806-165	€45.48	SUPPORT, trunk lip, LH	1	
98	856-150	€98.16	BOOT FLOOR, rear section	1	BN4, BN6, BN7, BT7, BJ7
	856-155	€225.36	BOOT FLOOR, rear section	1	BJ8
100	856-320	€91.44	BOOT SIDE BOX, RH	1	
	856-325	€91.44	BOOT SIDE BOX, LH	1	
102	856-330	€46.68	BATTERY CABLE PANEL	1	
103	805-830	€73.68	BRACKET, battery base support	1	BN4, BT7, BJ7, BJ8
104	031-412	€11.64	BRACKET, battery switch	1	
110	SC40	€25.44	BUMP STOP BOX	2	BN4 thru BJ8 (c)26704 (mounting hardware listed on pg. 74)
	806-200	€28.80	BUMP STOP BOX	2	BJ8 from (c)26705 (mounting hardware listed on pg. 75)

ill. Part Number Price €ea. Description Req. Details

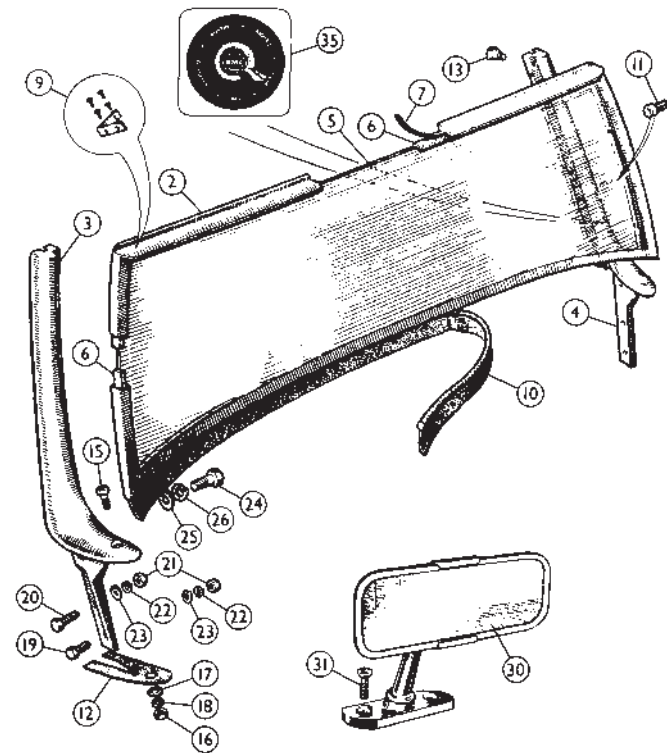

Windscreen BN4, BN6, BN7, BT7

2	NA	WINDSCREEN ASSEMBLY	1	BN4 to C.E.54754
	NA	WINDSCREEN ASSEMBLY	1	BN4 from C.E.54755, BN6, BN7, BT7
	NA	FRAME ASSEMBLY, windscreen	1	BN4 to C.E.54754
	NA	FRAME ASSEMBLY, windscreen	1	BN4 from C.E.54755, BN6, BN7, BT7
3	NA	PILLAR, RH	1	
4	NA	PILLAR, LH	1	
5	14B58910E	GLASS, windscreen, Pilkington/Triplex	1	
	14B5891	GLASS, windscreen, aftermarket	1	
6	SC250	GLAZING SEAL	1	
7	682-027	FILLER STRIP	1	b/n glazing seal & frame
9	805-060	BRACKET KIT, windscreen frame	1	4 corner brackets & screws
10	14B5892	SEAL, windscreen frame to body	1	
11	54K195	SCREW, frame to pillar	8	
12	14B6743	PAD, pillar foot, rubber	2	
13	805-125	STUD, toggle clamp retaining	2	
15	SG604083	SCREW, pillar to scuttle top	2	
16	GHF200	NUT	2	
17	WM57	WASHER, plain	2	
18	GHF331	WASHER, locking	2	
19	GHF101	BOLT, windscreen to scuttle side panel, 1"	3	
20	NA	BOLT, windscreen to scuttle side panel	1	1-1/4"
21	GHF200	NUT	4	
22	GHF300	WASHER, plain	4	
23	GHF331	WASHER, locking	4	
24	NA	BOLT, windscreen to scuttle side panel	2	1-1/4"
25	WP9	WASHER, plain	2	
26	GHF332	WASHER, locking	2	
30	14B1867	MIRROR, driving	1	
31	RMP312	SCREW	2	
35	NA	TAX DISC HOLDER, 'BMC' Rosette	1	UK market

ill. Part Number Price €ea. Description Req. Details

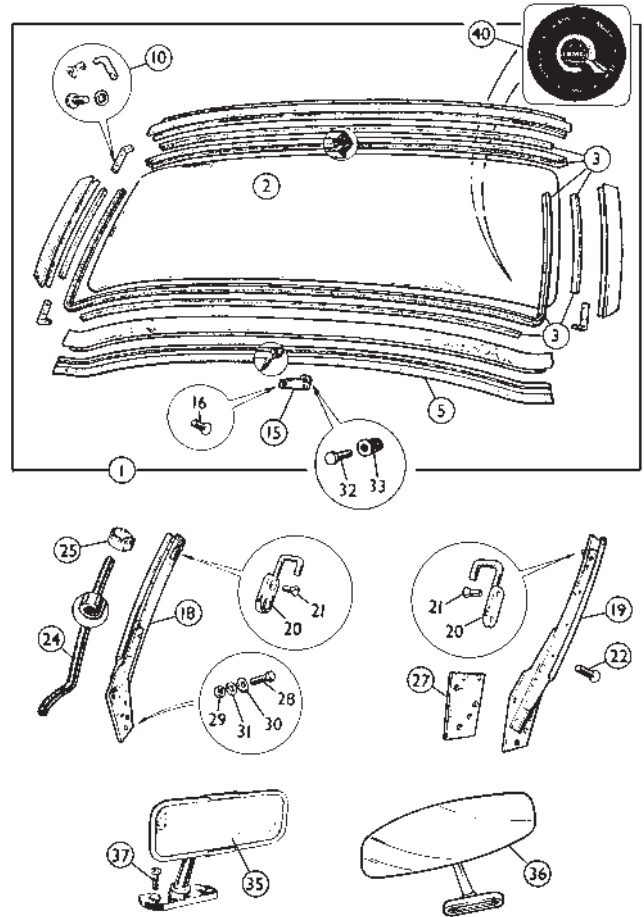

Windscreen BJ7, BJ8

1	NA	WINDSCREEN ASSEMBLY	1	
2	AHB94240E	GLASS, windscreen, Pilkington/Triplex	1	
	AHB9424	GLASS, windscreen, aftermarket	1	
3	682-028	GLAZING SEAL KIT	1	
		(all rubber between glass & frame)		
5	AHB9787	SEAL, windscreen, bottom	1	
10	031-413	BRACKET KIT, windscreen frame	1	4 corner brackets & screws
15	NA	BRACKET, centre	1	
16	NA	SCREW, centre bracket to top channel	2	
17	WL700101	WASHER, shakeproof	8	
18	NA	PILLAR, RH	1	
19	NA	PILLAR, LH	1	
20	031-428	HOOK PAIR, toggle	1	
21	NA	RIVET, hook	4	
22	AJD2246	SCREW, pillar to windscreen	8	
24	249-615	PILLAR SEAL SET, black	1	
25	AHB9788	CAP, seal top, RH	1	
	AHB9789	CAP, seal top, LH	1	
27	031-416	PACKING, foot	A/R	
28	GHF101	BOLT, 1"	6	BJ7
	GHF117	SCREW, 3/4"	2	
	GHF101	BOLT, 1"	1	
	GHF117	SCREW, 3/4"	5	BJ8
	NA	BOLT, 1-1/8"	2	
29	GHF200	NUT	8	
30	GHF300	WASHER, plain	8	
31	GHF331	WASHER, locking	8	
32	GHF117	SCREW, centre bracket	1	
33	NA	NUT	1	
35	14B1867	MIRROR, driving	1	BJ7, BJ8 to (b)73213
36	AHB6920	MIRROR, driving	1	BJ8 from (b)73214
37	RMP312	SCREW	2	
40	CRLH402	TAX DISC HOLDER, 'BMC' Rosette	1	UK market

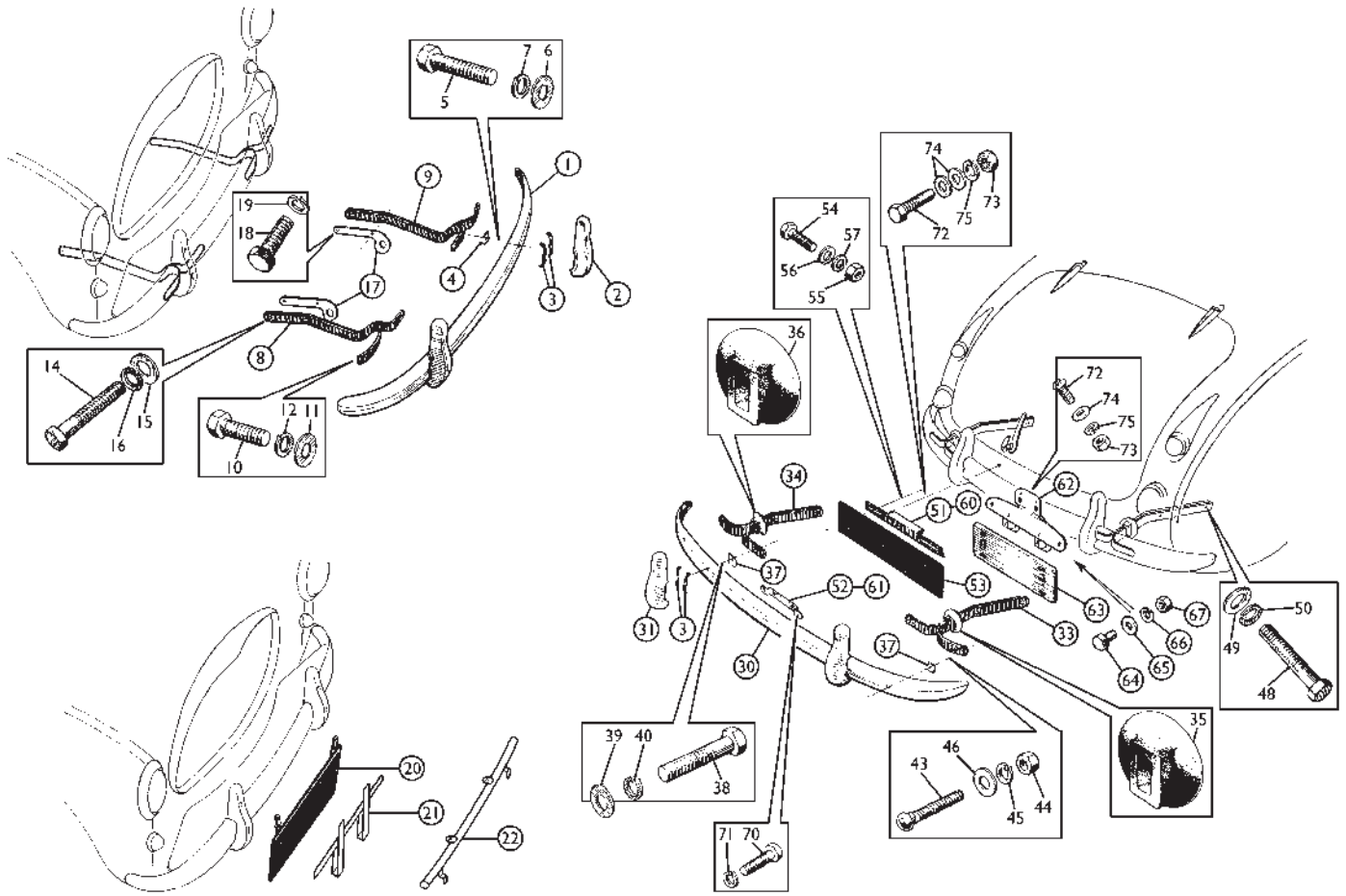

iii. Part Number Price €ea. Description Req. Details

Bumpers & Number Plates 100-6, 3000

iii.	Part Number	Price €ea.	Description	Req.	Details
1	11B5303	€318.00	BUMPER BAR, front	1	
	11B5303Z	€308.40	BUMPER BAR, front, aftermarket	1	
2	11B5308	€63.60	OVERRIDER, front	2	
3	37H9871M	€3.36	SEAL, overrider, per metre	1	
4	031-417	€4.32	PACKING, ft. overrider bolts	2	
5	SH606101	€1.08	BOLT, overrider to bumper	2	
6	WP9	€2.04	WASHER, plain	2	
7	GHF333	€0.72	WASHER, locking	2	
8	17H9701	€48.84	SPRING BAR ASSY, front, RH	1	
9	17H9702	€48.84	SPRING BAR ASSY, front, LH	1	
10	GHF105	€0.84	BOLT, bumper & number plate bracket to spring bar	4	
11	WP9	€2.04	WASHER, plain	4	
12	GHF333	€0.72	WASHER, locking	4	
14	BH606111	€2.28	BOLT, spring bar to chassis	4	
15	WP9	€2.04	WASHER, plain	4	
16	GHF333	€0.72	WASHER, locking	4	
17	031-426	€39.48	TOWING EYE PAIR, with hardware	1	optional (required for
18	SH606061	€1.44	BOLT, towing eye	4	Canada from 1963-on)
19	GHF333	€0.72	WASHER, locking	4	
20	806-390	€42.48	SUPPORT, front number plate	1	UK style
21	806-730	€85.20	BRACKET, mounting, number plate	1	N. American style
22	870-132	€129.00	BADGE BAR with fog/driving lamp brackets	1	
	870-131	€123.36	BADGE BAR, without lamp brackets	1	
	408-579	€22.80	BRACKET, fog/driving lamp	2	
30	11B5312	€318.00	BUMPER BAR, rear, reproduction	1	
	11B5312Z	€308.40	BUMPER BAR, rear, replacement	1	
31	11B5308	€63.60	OVERRIDER, rear	2	
33	804-290	€60.36	SPRING BAR ASSY, rear, RH	1	
34	804-280	€60.36	SPRING BAR ASSY, rear, LH	1	
35	1A9307	€8.64	GROMMET, spring bar, RH	1	
36	1A9308	€8.64	GROMMET, spring bar, LH	1	
37	031-417	€4.32	PACKING, spring bar to bumper	4	
38	BH606161	€1.32	BOLT, spring bar to bumper and overrider	2	
39	WP9	€2.04	WASHER, plain	2	
40	GHF333	€0.72	WASHER, locking	2	
43	37H9659	€3.48	BOLT, chrome, spring bar to bumper	2	incl. #44 & 45
44	GHF202	€0.72	NUT	2	
45	GHF333	€0.72	WASHER, locking	2	
46	WP9	€2.04	WASHER, plain	2	
48	BH606111	€2.28	BOLT, spring bar to chassis	4	
49	WP9	€2.04	WASHER, plain	4	
50	GHF333	€0.72	WASHER, locking	4	
51	806-360	€15.00	BRACKET, number plate to body	1	All UK cars; Europe BN4,
52	031-418	€10.08	BRACKET, lamp to bumper	1	BN6, BN7/BT7 to (c)13487

iii. Part Number Price €ea. Description Req. Details

53	ALK3268	€9.12	SUPPORT, rear number plate	1	
54	SH604041	€0.84	BOLT, support to bracket	2	
55	GHF200	€0.96	NUT	2	all UK cars
56	WM57	€1.20	WASHER, plain	2	
57	GHF331	€0.84	WASHER, locking	2	
60	806-360	€15.00	BRACKET, number plate to body	1	N. America BN4, BN6,
61	031-418	NA	BRACKET, lamp to bumper	1	BN7, BT7, BJ7, BJ8 to (b) 79899
62	806-365	€158.76	BRACKET, support and lamp to bumper	1	
63	AHA5211	€13.20	SUPPORT, number plate	1	N. America BJ8 from
64	SH604031	€2.28	BOLT, support to bracket	2	(b)79900 (will fit all 100-6 & 3000)
65	GHF300	€1.08	WASHER, plain	4	
66	GHF331	€0.84	WASHER, locking	4	
67	GHF200	€0.96	NUT	4	
70	SH604051	€0.72	BOLT, bracket to bumper	2	for bumper
71	GHF331	€0.84	WASHER, locking	2	mounted brackets
72	SH604051	€0.72	BOLT, bracket to body	2	
73	GHF200	€0.96	NUT	2	for body
74	GHF300	€1.08	WASHER, plain	4	mounted brackets
75	GHF331	€0.84	WASHER, locking	2	

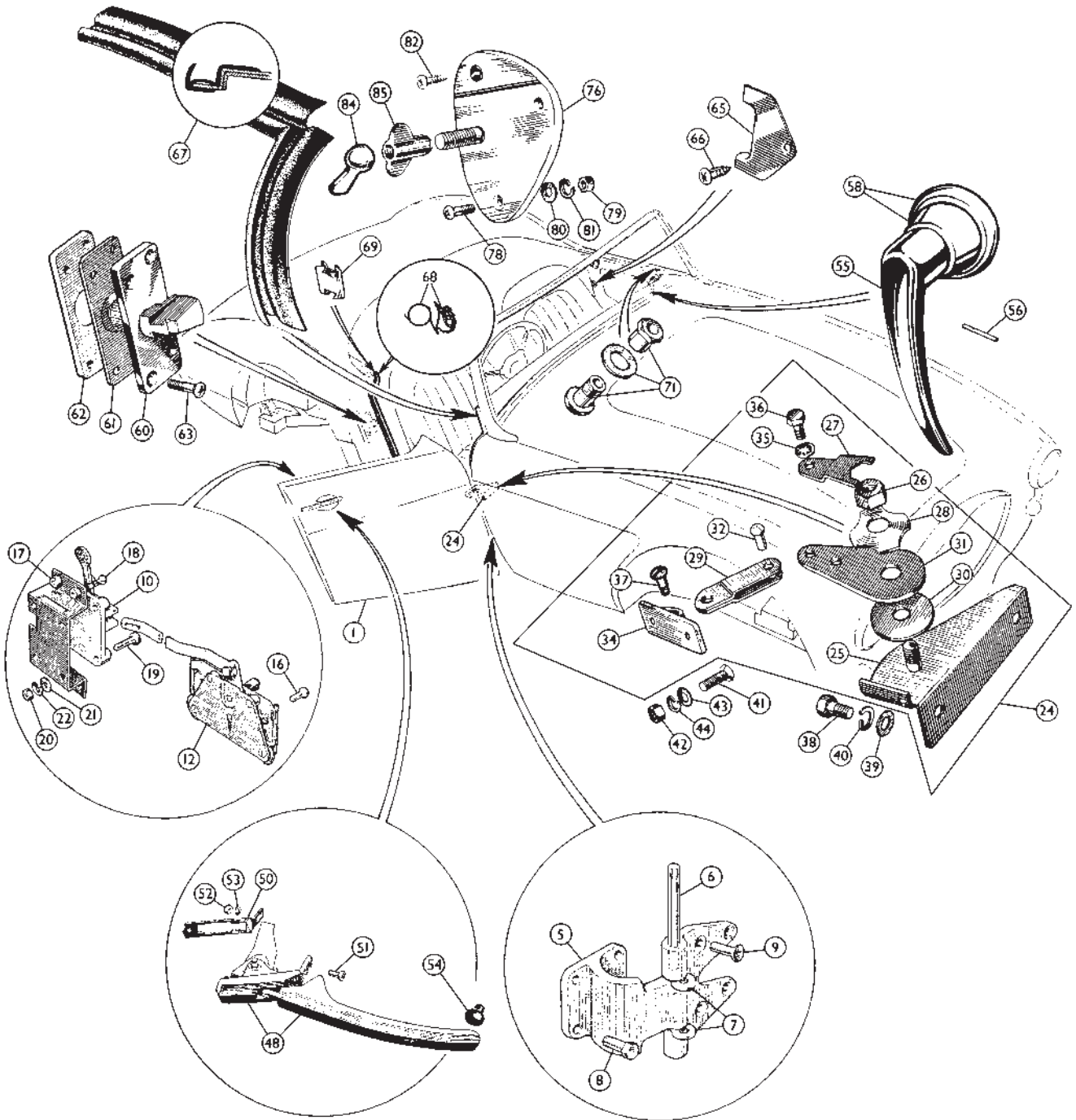

iii.	Part Number	Price €ea.	Description	Req.	Details	iii.	Part Number	Price €ea.	Description	Req.	Details	
Doors and Fittings BN4, BN6, BN7, BT7						78	RMP310	€1.44	SCREW, plate	4		
1	856-205	NA	DOOR ASSEMBLY, bare, steel, RH	1	original material	79	GHF206	€1.32	NUT	4		
	856-215	NA	DOOR ASSEMBLY, bare, steel, LH	1			80		NA	WASHER, plain	4	
	858-075	€1,018.80	DOOR ASSEMBLY, bare, aluminium, RH	1	alternative	81	GHF331	€0.84	WASHER, locking	4		
	858-085	€1,018.80	DOOR ASSEMBLY, bare, aluminium, LH	1			82		NA	SCREW, plate	2	
	856-225	€620.40	DOOR SKIN, steel, RH	1	original material	84	MB19331	€11.16	NUT, sidecurtain (3/8", 16 tpi)	2	BN4 to C.E.68959	
	856-235	€620.40	DOOR SKIN, steel, LH	1			85	24B540	€7.92	NUT, sidecurtain (5/16", 24 tpi)	2	BN4 from C.E.68960 thru BT7
	856-640	€620.40	DOOR SKIN, aluminium, RH	1	alternative							
	856-650	€620.40	DOOR SKIN, aluminium, LH	1								
	857-580	€66.96	SKIN REPAIR, lower, steel, RH	1								
	857-590	€66.96	SKIN REPAIR, lower, steel, LH	1								
	856-635	€44.16	REPAIR, lower frame, steel, RH	1								
	856-645	€44.16	REPAIR, lower frame, steel, LH	1								
5	031-425	€166.56	HINGE, door	4								
6		NA	HINGE PIN	4								
7		NA	WASHER, hinge pin	8								
8	GHF103	€1.20	BOLT, hinge to door	16								
9	SF605081	€1.08	SCREW, hinge to body	16								
10	14B7481	€84.48	DOOR LATCH ASSY, RH	1								
	14B7482	€84.48	DOOR LATCH ASSY, LH	1								
12		NA	REMOTE CONTROL UNIT, RH	1	BN4, BN6							
		NA	REMOTE CONTROL UNIT, LH	1								
		NA	SCREW, lock and remote control	6								
		NA	WASHER, plain	6								
		NA	WASHER, shakeproof	6	BN7, BT7							
		NA	SCREW, lock and remote control	6								
16		€36.60	BRACKET, lock mounting, RH	1								
17	031-420	€36.60	BRACKET, lock mounting, LH	1								
	031-421	€36.60	BRACKET, lock mounting, LH	1								
18	CMZ305	€1.20	SCREW, bracket to door	4								
19	RMP310	€1.44	SCREW, lock to bracket	8								
20	GHF200	€0.96	NUT	8								
21		NA	WASHER, plain	8								
22	GHF331	€0.84	WASHER, locking	8								
24	805-630	€72.00	CHECK STRAP ASSEMBLY, RH	1								
	805-620	€72.00	CHECK STRAP ASSEMBLY, LH	1								
25		NA	BRACKET & STUD ASSY, RH	1								
		NA	BRACKET & STUD ASSY, LH	1								
26		NA	NUT, stud, LH thread	1								
		NA	NUT, stud, RH thread	1								
27		NA	SPANNER, friction	2								
28		NA	WASHER, locking	2								
29		NA	LINK, connection	2								
30	805-235	€2.52	DISC, friction	2								
31		NA	ARM	2								
32		NA	PIN	2								
34	806-815	€8.40	BRACKET, check strap	2								
35	WL700101	€1.20	WASHER, shakeproof	2								
36		NA	BOLT	2								
37		NA	SCREW, shouldered	2								
38	SH604041	€0.84	BOLT, check strap to hinge pillar	4								
39	GHF300	€1.08	WASHER, plain	4								
40	GHF331	€0.84	WASHER, locking	4								
41	RMP310	€1.44	SCREW, check strap to door	4								
42	GHF206	€1.32	NUT	4								
43		NA	WASHER, plain	4								
44	GHF331	€0.84	WASHER, locking	4								
	021-726	€118.44	DOOR HANDLE, non-locking, RH	1	BN4 to C.E.48386 LHD, to 48113 RHD							
		NA	DOOR HANDLE, locking, LH	1								
48	021-726	€118.44	DOOR HANDLE, non-locking, RH	1	BN4 from C.E.48387 LHD, 48114 RHD, BN6, BN7, BT7							
	021-727	€118.44	DOOR HANDLE, non-locking, LH	1								
49	031-422	€6.00	SPRING, door handle lever	2								
50	698-110	€2.64	GASKET, seating	2								
51	AJD2246	€1.32	SCREW, door handle to door panel	2								
52	GHF206	€1.32	NUT	2								
53	GHF331	€0.84	WASHER, locking	2								
54	633-760	€1.80	BUFFER, door handle	2								
55	ADG1673	€26.16	DOOR HANDLE, interior	2								
56	ALH1527	€2.04	PIN, handle securing	2								
58	ADB709	€29.52	ESCUTCHEON & SPRING	2								
60	612856	€49.44	STRIKER, door lock	2								
61	805-195	€5.16	PLATE, packing	2								
62	805-155	€21.24	PLATE, tapped	2								
63	RMP312	€1.20	SCREW, striker	8								
65	14B2544	€7.92	ESCUTCHEON, door trim protection	2								
66	AD604043	€1.20	SCREW, plate	2								
67		NA	SEAL SET, door to scuttle (2 pcs.) (Not available. Use later 680-928)	1	BN4 to C.E.50758							
	680-928	€47.28	SEAL SET, door to scuttle (2 pcs.)	1	BN4 from C.E.50759, BN6, BN7, BT7							
	682-128	NA	RUBBER DOOR SEAL SET	1	BN4 to C.E.68959							
	805-158	€109.56	CHANNEL SET, door seal (6 pieces)	1								
*The 682-128 rubber door seal set is unique in that it slides into metal channels that are screwed to the body.												
68	DER4001	€27.60	DOOR SEAL, red, per meter	4	BN4 from C.E.68960, BN6, BN7, BT7							
	DEL4001	NA	DOOR SEAL, blue, per meter	4								
	DEA4001	€27.36	DOOR SEAL, black, per meter	4								
		NA	DOOR SEAL, grey, per meter	4								
69	249-795	€1.08	CLIP, door seal	A/R								
71	805-120	€14.76	SOCKET AND NUT KIT, sidecurtain	2								
76	AAAS154	€13.08	PLATE, sidecurtain (3/8", 16 tpi)	2	BN4 to C.E.68959							
	24B1656	€12.48	PLATE, sidecurtain (5/16", 24 tpi)	2	BN4 from C.E.68960 thru BT7							
	805-105	€7.44	HARDWARE SET, plate mounting	1	for 2 doors							

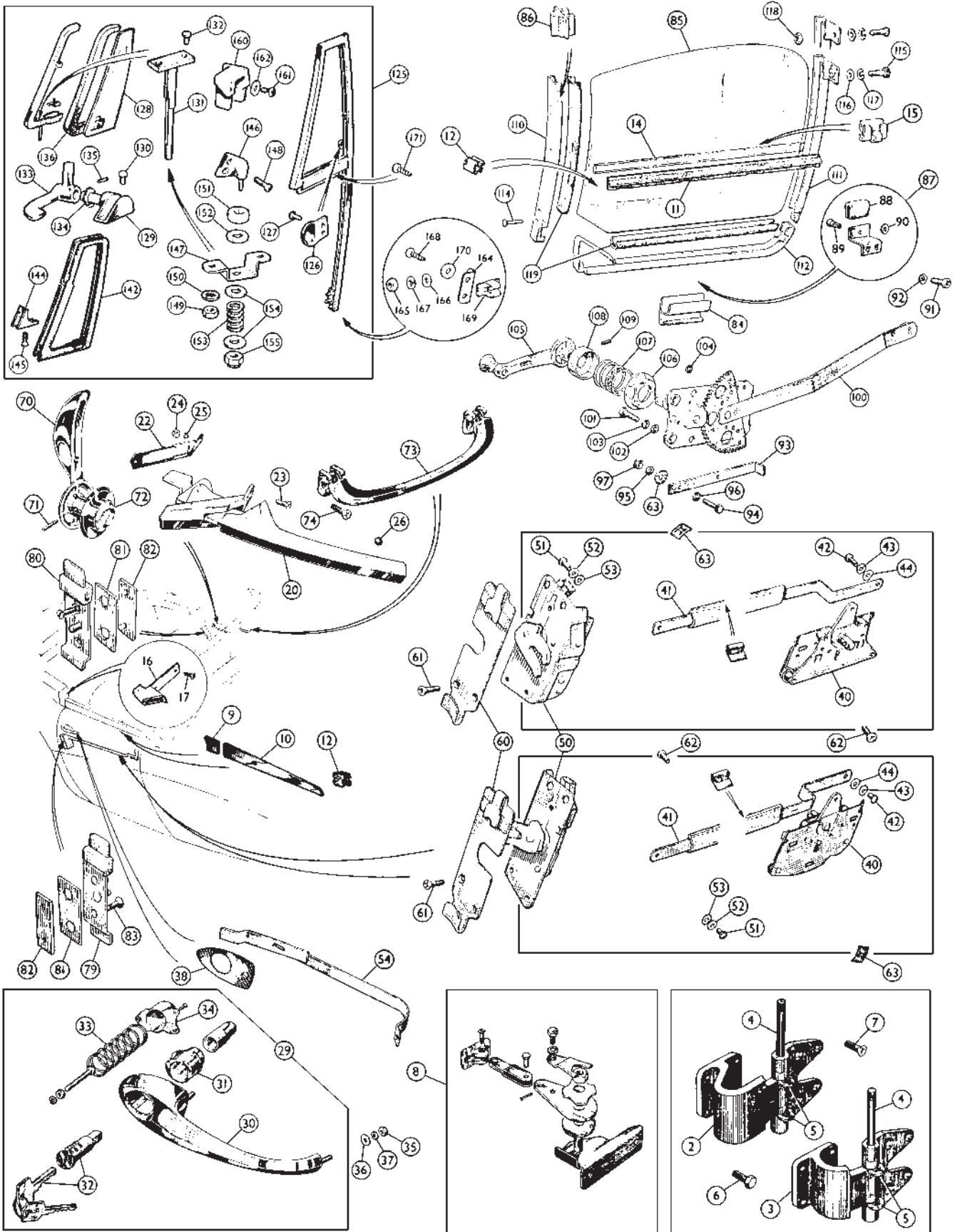

ill.	Part Number	Price €ea.	Description	Req.	Details
Doors and Fittings BJ7, BJ8					
1	NA		DOOR AND REPAIR PANELS	2	see page 121
2	031-430	€166.56	DOOR HINGE, upper	2	
3	031-425	€166.56	DOOR HINGE, lower	2	
4	NA		HINGE PIN	4	
5	NA		WASHER, hinge pin	8	
6	GHF103	€1.20	BOLT, hinge to door, 1"	12	
	GHF120	€0.72	BOLT, hinge to door, 3/4"	4	
7	SF605081	€1.08	SCREW, hinge to body	16	
8	805-630	€72.00	CHECK STRAP ASSEMBLY, RH	1	
	805-620	€72.00	CHECK STRAP ASSEMBLY, LH	1	
9	805-210	€50.52	FINISHER, rear quarter panel, RH	1	BJ7, BJ8
	805-220	€50.52	FINISHER, rear quarter panel, LH	1	
10	805-190	€142.44	MOULDING, door waist, RH	1	
	805-200	€142.44	MOULDING, door waist, LH	1	
11	AHH6349	€6.48	SEAL, door glass, outer, RH	1	
	AHH6348	€6.48	SEAL, door glass, outer, RH	1	
12	BHA4359	€0.84	CLIP, moulding and weather strip	A/R	
14	AHH7848	€8.28	WEATHER STRIP, inner	2	
15	GHF1582	€1.08	CLIP, inner weather strip to door	8	
16	AHB9931	€27.24	SEAL, shut pillar, top, LH	1	BJ7 from (b)57500, BJ8
	AHB9930	€27.24	SEAL, shut pillar, top, RH	1	
17	NA		SCREW, seal attaching	4	
20	021-728	€118.44	DOOR HANDLE, RH	1	
	021-729	€118.44	DOOR HANDLE, LH	1	
21	031-422	€6.00	SPRING, door handle lever	2	
22	698-110	€2.64	GASKET, seating	2	BJ7, BJ8 to (c)26704
23	AJD2246	€1.32	SCREW, door handle to door panel	2	
24	GHF206	€1.32	NUT	2	
25	GHF331	€0.84	WASHER, locking	2	
26	633-760	€1.80	BUFFER, handle	2	
29	021-789	€139.56	DOOR HANDLE ASSY (complete)	2	
30	021-730	€68.16	DOOR HANDLE, locking (bare)	2	
31	031-775	€33.12	BUTTON	2	
32	805-250	€25.20	BARREL, lock and 2 keys	2	
33	021-348	€5.76	SPRING	2	BJ8 from (c)26705
34	031-776	€31.92	CUP, retaining	2	
35	GHF206	€1.32	NUT	4	
36	PWZ203	€0.96	WASHER, plain	4	
37	GHF331	€0.84	WASHER, locking	4	
38	698-115	€1.80	GASKET, handle	2	
40	NA		REMOTE CONTROL ASSEMBLY	2	
41	NA		CONNECTING LINK	2	
42	NA		RIVET, link to remote control	2	
43	GHF300	€1.08	WASHER, plain	2	
44	NA		WASHER, anti-rattle	2	
50	803-866	€123.36	LOCK ASSEMBLY, RH	1	BJ7, BJ8
	803-836	€123.36	LOCK ASSEMBLY, LH	1	
51	NA		RIVET, link to remote control	4	
52	GHF300	€1.08	WASHER, plain	4	
53	NA		WASHER, anti-rattle	4	
54	804-005	€75.24	CONTACT, door lock, LH	1	
	804-015	€75.24	CONTACT, door lock, RH	1	BJ8 from (c)26705
	AJD7721	€0.84	WASHER, locking	2	
60	803-865	€38.04	LOCK PLATE, RH	1	
	803-835	€38.04	LOCK PLATE, LH	1	
61	RMZ308	€1.32	SCREW, lock & plate to door	6	
62	NA		SCREW, remote control to door	6	
63	NA		NUT, spire	6	
70	14G3763	NA	DOOR HANDLE, interior	2	
71	NA		PEG, handle	2	
72	14G3764	€18.72	ESCUTCHEON, door handle	2	
73	650306	€27.00	DOOR PULL	2	
74	314-251	€1.08	SCREW, handle to door	4	
79	803-755	€39.96	STRIKER, door lock, RH	1	
80	803-765	€39.96	STRIKER, door lock, LH	1	
81	021-347	€5.76	PLATE, packing, striker	2	
82	021-349	€9.96	PLATE, tapped, striker	2	
83	SF605061	€1.68	SCREW, striker	4	
84	324-112	€47.88	BRACKET, regulator to channel	2	
85	AHB9425	€117.84	DOOR GLASS, RH	1	
	021-859	€261.60	DOOR GLASS, RH, Triplex	1	
	AHB9426	€117.84	DOOR GLASS, LH	1	
	021-858	€261.60	DOOR GLASS, LH, Triplex	1	
86	AHB9499	€2.52	GUIDE, door glass, nylon	6	
87	NA		BUFFER STOP ASSEMBLY	2	
88	14B766	€1.56	BUFFER, rubber	2	
89	325-765	€1.32	RIVET	2	
90	325-770	€0.72	WASHER, copper	6	
91	NA		SCREW, buffer stop to door	4	
92	WL700101	€1.20	WASHER, shakeproof	4	
93	NA		BRACKET, stop, door glass	2	
94	SH604051	€0.72	SCREW, bracket to door	4	
95	GHF300	€1.08	WASHER, plain	4	
96	GHF331	€0.84	WASHER, locking	4	
97	GHF200	€0.96	NUT	8	
100	021-900	€123.48	REGULATOR MECHANISM, window, LH	1	BJ7
	021-905	€123.48	REGULATOR MECHANISM, window, RH	1	
	021-910	€123.48	REGULATOR MECHANISM, window, LH	1	BJ8
	021-915	€123.48	REGULATOR MECHANISM, window, RH	1	
101	SE604041	€0.84	SCREW, regulator to door	8	
102	GHF300	€1.08	WASHER, plain	8	

ill.	Part Number	Price €ea.	Description	Req.	Details
103	GHF331	€0.84	WASHER, locking	8	
104	NA		RING, anti-rattle, regulator	2	
105	14G6503	NA	WINDOW WINDER HANDLE	2	
106	805-640	€16.80	ESCUTCHEON	2	
107	031-320	€3.48	SPRING	2	shorten by 1-1/2 coils to fit
108	805-650	€6.12	CROWN	2	
109	NA		PEG	2	
	021-938	NA	CHANNEL SET, LH (3 pieces)	1	
	021-948	NA	CHANNEL SET, RH (3 pieces)	1	
110	NA		CHANNEL, front	2	
111	NA		CHANNEL, rear, LH	1	
	NA		CHANNEL, rear, RH	1	
112	021-958	€112.56	CHANNEL, lower (replacement)	2	
114	GHF600	€0.84	RIVET, front to lower channels	4	
115	53K126	€1.08	SCREW, rear channel to door	4	
116	NA		WASHER, plain	4	
117	GHF331	€0.84	WASHER, locking	4	
118	GHF206	€1.32	NUT	4	BJ7, BJ8 to (b)57499
119	680-307	€4.32	GLAZING STRIP, glass	2	
125	NA		VENT WINDOW ASSY, LH	1	
	NA		VENT WINDOW ASSY, RH	1	
126	031-758	NA	PLATE, handle locking	2	
127	NA		RIVET, plate to frame	4	
128	021-865	NA	GLASS, vent window LH	1	
	021-875	€124.32	GLASS, vent window, RH	1	
129	804-025	NA	BRACKET, handle, LH	1	
	804-035	NA	BRACKET, handle, RH	1	
130	NA		RIVET, bracket to frame	4	
131	031-761	NA	PIVOT, lower, LH	1	
	031-762	NA	PIVOT, lower, RH	1	
132	NA		RIVET, pivot to frame	4	
133	803-855	€47.88	HANDLE, locking, LH	1	
	803-845	€47.88	HANDLE, locking, RH	1	
134	NA		WASHER, anti-rattle	2	
135	NA		PIN, handle to bracket	2	
136	078447A	€9.24	GLAZING RUBBER	2	per foot
142	17H2855	€30.36	SEALING RUBBER, LH	1	
	17H2854	€30.36	SEALING RUBBER, RH	1	
144	NA		BLOCK, front corner	2	
145	NA		SCREW, block to outer frame	2	
146	803-935	€62.52	BRACKET, top pivot, outer, LH	1	
	803-925	NA	BRACKET, top pivot, outer, RH	1	
147	NA		BRACKET, lower pivot, outer, LH	1	
	NA		BRACKET, lower pivot, outer, RH	1	
148	NA		SCREW, top bracket to frame	4	
149	AJD8012Z	€0.72	NUT, lower bracket to frame	4	
150	WL700101	€1.20	WASHER, shakeproof	4	
151	NA		COLLAR, lower pivot	2	
152	GHF300	€1.08	WASHER, plain	2	
153	NA		SPRING, lower pivot	2	
154	GHF300	€1.08	WASHER, plain	4	
155	NA		NUT, lower pivot	2	
160	681-008	€5.76	TIP SET, top corner	1	LH & RH tips
161	NA		SCREW, block to frame	2	
162	NA		WASHER, plain	2	
164	NA		BRACKET, vent window to door	2	
165	GHF206	€1.32	NUT	4	
166	NA		WASHER, plain	4	
167	GHF331	€0.84	WASHER, locking	4	
168	NA		SCREW, vent window to door	8	
169	326-245	€2.52	NUT, spire	8	
170	NA		WASHER, plain	8	
171	NA		SCREW, vent window to door	4	

Note: Door seal is listed on page 139.

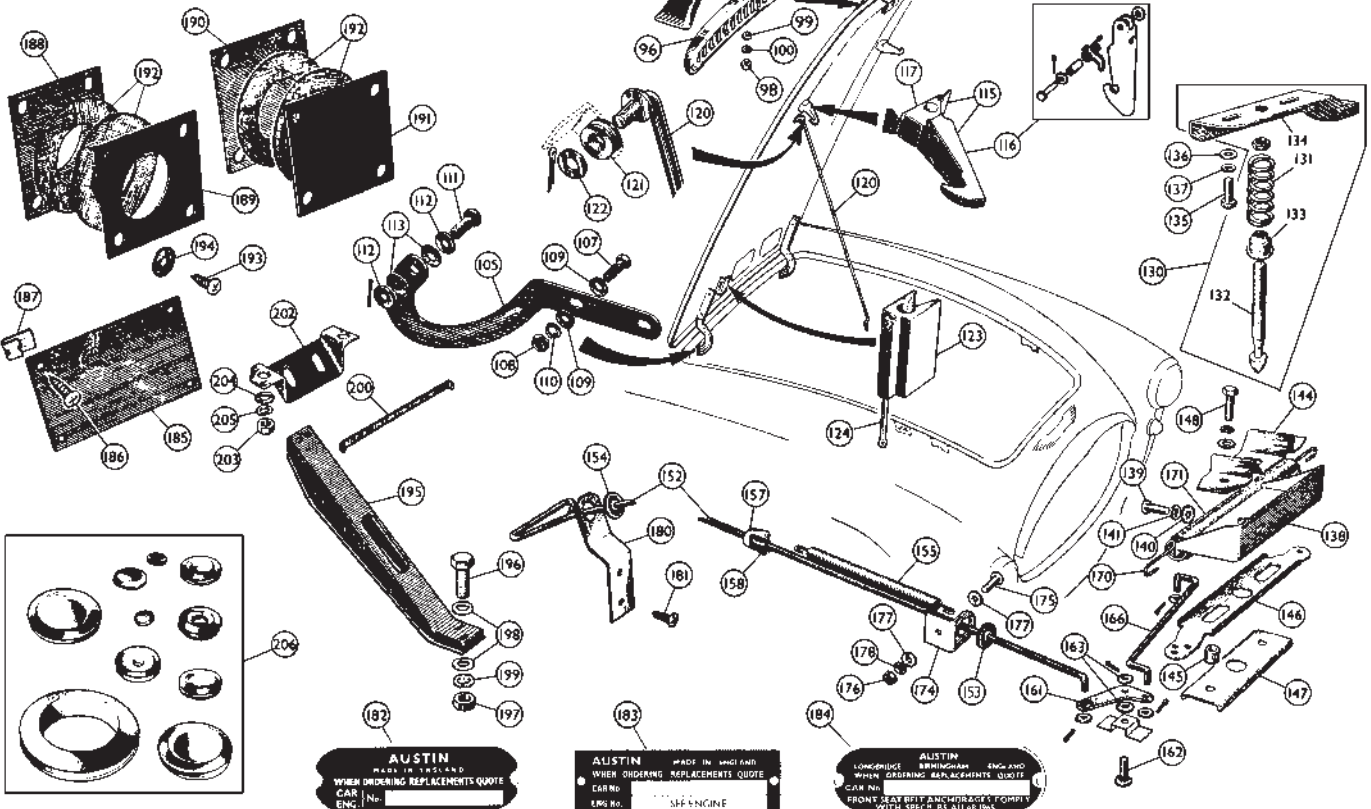
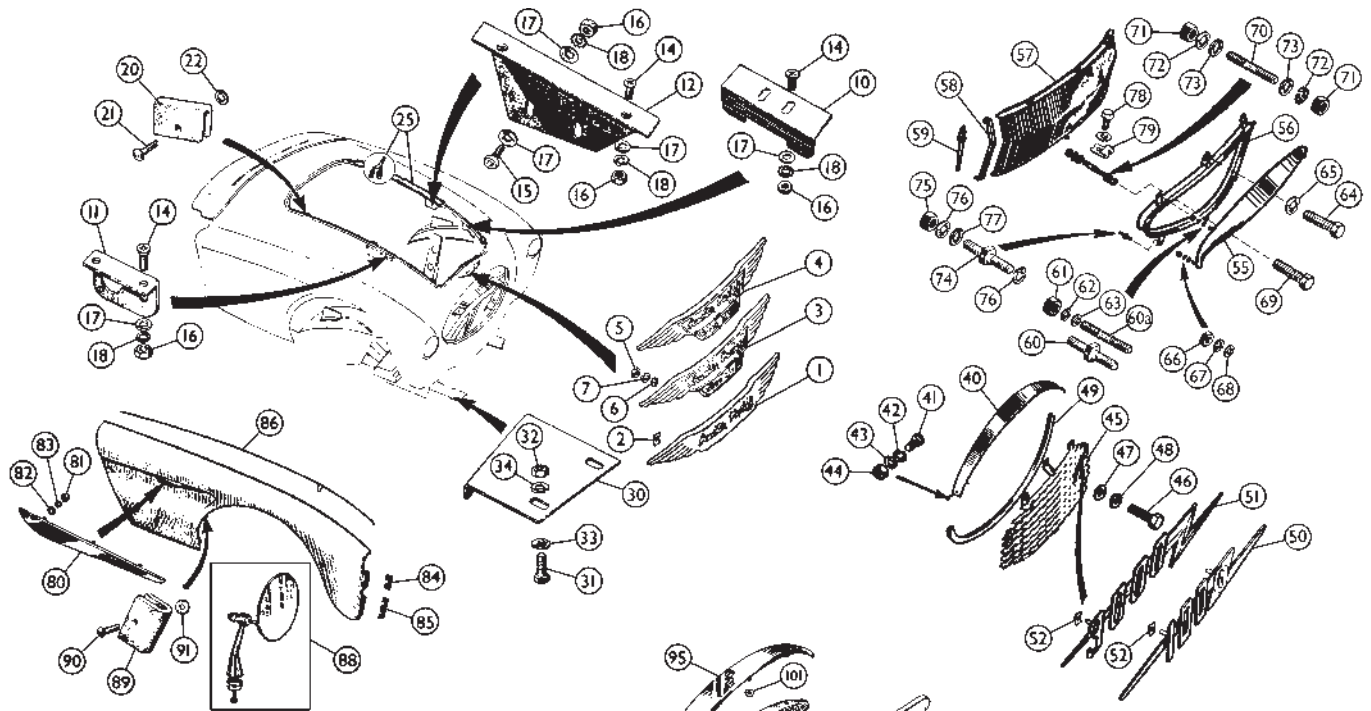

AUSTIN
MADE IN ENGLAND
WHEN ORDERING REPLACEMENTS QUOTE
CAR NO. _____
ENG. NO. _____

AUSTIN
MADE IN ENGLAND
WHEN ORDERING REPLACEMENTS QUOTE
CAR NO. _____
ENG. NO. _____
SPE-ENGINE

AUSTIN
LONGBRIDGE BRIDGEHEAD ENG. AND
WHEN ORDERING REPLACEMENTS QUOTE
CAR NO. _____
FRONT SEAT BOLT ANCHORAGE POINTS
WITH SPEC. BUSHINGS

ill.	Part Number	Price €ea.	Description	Req.	Details
Front Body Fittings 100-6, 3000					
Shroud Fittings & Grilles					
1	14B1723	€101.52	BADGE, Austin Healey wings	1	BN4, BN6, BN7/BT 2
	ADB509	NA	NUT, spire	2	to (c)13750
3	601-280	€244.80	BADGE, Austin Healey MK II	1	BN7/BT7 from (c)13751, BJ7
4	021-739	€202.80	BADGE, Austin Healey MK III	1	BJ8
5	GHF206	€1.32	NUT	2	BN7/BT7 from (c)13751,
6	GHF306	€0.72	WASHER, plain	2	BJ7, BJ8
7	GHF331	€0.84	WASHER, locking	2	
10	805-485	€17.16	STRIKER, bonnet safety catch	2	
11	805-395	NA	BRACKET, stay, bonnet prop rod	1	BN4 (use later bracket)
	805-475	€10.20	BRACKET, stay, bonnet prop rod	1	BN6, BN7, BT7, BJ7, BJ8
	805-580	€6.84	BRACKET, shroud support, RH	1	
12	805-590	€6.84	BRACKET, shroud support, LH	1	
14	CMZ308	€0.72	SCREW, strikers/brackets to shroud	10	
15	PMZ308	€0.72	SCREW, support bracket to upright	4	
16	GHF206	€1.32	NUT	14	
17	PWZ203	€0.96	WASHER, plain	18	
18	GHF331	€0.84	WASHER, locking	14	
20	14B766	€1.56	BUFFER, rubber	5/4	qty. reduced from BN7/
21	325-765	€1.32	RIVET, buffer to hood surround	5/4	BT7 (c)13751
22	325-770	€0.72	WASHER, copper	5/4	
25	AHB9095	€7.44	STRIP, bonnet surround sealing, LH	1	
30	805-285	€6.84	BRACKET, shroud to chassis, RH	1	
	805-295	€6.84	BRACKET, shroud to chassis, LH	1	
31	SH604051	€0.72	SCREW, bracket to cowl lower panel	4	
32	GHF200	€0.96	NUT	4	
33	GHF300	€1.08	WASHER, plain	8	
34	GHF331	€0.84	WASHER, locking	4	
40	870-090	€435.60	COWL, grille	1	
41	PMP308	€1.32	SCREW	2	
42	GHF306	€0.72	WASHER, plain	2	
43	GHF331	€0.84	WASHER, locking	2	
44	GHF206	€1.32	NUT	2	BN7/BT7 to
45	14B5759	€486.00	GRILLE	1	BN4, BN6,
46	SH604051	€0.72	SCREW	6	(c)13750
47	GHF300	€1.08	WASHER, plain	6	
48	GHF331	€0.84	WASHER, locking	6	
49	870-100	€58.44	MOULDING, grille	1	
50	14B5772	€23.88	MOTIF, '100/6'	1	BN4, BN6
51	AHB8861	€17.04	MOTIF, '3000'	1	BN7/BT7 to (c)13750
52	326-510	€0.96	FIXING, motif	2	
55	AHB9001	€399.60	COWL, grille	1	
56	AHB8999	€921.60	SURROUND, grille	1	
57	AHB9000	€392.40	GRILLE	1	BN7/BT7 from (c)13751,
58	870-070	€11.16	SLAT	39	BJ7, BJ8
59	NA		RIVET, pop type	156	
60	805-465	€3.48	STUD, cowl top, outer	2	
60a	NA		STUD, cowl top	3	BJ7, BJ8
61	GHF200	€0.96	NUT	2/3	BN7/BT7 from (c)13751,
62	GHF331	€0.84	WASHER, locking	2/3	BJ7, BJ8
63	GHF300	€1.08	WASHER, plain	2/3	
64	SH604051	€0.72	BOLT	1	BN7/BT7 from (c)13751
65	GHF331	€0.84	WASHER, locking	1	
66	NH806011	€0.96	NUT	2	BN7/BT7 from (c)13751,
67	WL700061	€0.72	WASHER, locking	2	BJ7, BJ8
68	NA		WASHER, plain	2	
69	SH604051	€0.72	BOLT, surround to slats, ctr. bottom	1	BN7/BT7 from (c)13751
	GHF300	€1.08	WASHER, plain	1	thru (c)14585, BJ7, BJ8
	GHF331	€0.84	WASHER, locking	2	
	GHF200	€0.96	NUT	1	
70	NA		STUD, surround to slats, ctr. bottom	1	
71	GHF200	€0.96	NUT	2	BN7/BT7 from (c)14586
72	GHF331	€0.84	WASHER, locking	2	
73	GHF300	€1.08	WASHER, plain	2	
74	NA		STUD, surround bottom, outer	2	
75	GHF200	€0.96	NUT	2	BN7/BT7 from (c)13751,
76	GHF331	€0.84	WASHER, locking	2	BJ7, BJ8
77	GHF300	€1.08	WASHER, plain	2	
78	NA		BOLT, slat assembly to body	2	
79	NA		NUT, spire	2	

Front Wing Fittings

80	14B1727	€17.16	FLASH, RH	1	premium quality
	14B1728	€17.16	FLASH, LH	1	reproduction
	GHF206	€1.32	NUT	6	
82	GHF306	€0.72	WASHER, plain	6	
83	GHF331	€0.84	WASHER, locking	6	
84	14B6824	€0.84	PIPING, above sidelamp, plastic	2	
85	14B6825	€0.96	PIPING, below sidelamp, plastic	2	
86	14B6729	€32.76	BEADING, front fender	2	
88	WM1906	€24.24	MIRROR, R/H, flat glass	1	
	WM1907	€24.24	MIRROR, L/H, flat glass	1	Lucas style
	WM1904	€24.24	MIRROR, R/H, convex glass	1	
	WM1905	€24.24	MIRROR, L/H, convex glass	1	
	280-140	€3.60	PAD, mirror stem	A/R	
	222-372	€61.20	MIRROR, flat glass	A/R	Racing style
89	14B766	€1.56	BUFFER, rubber, wheelarch	4	
90	325-765	€1.32	RIVET	4	
91	325-770	€0.72	WASHER, copper	6	

ill.	Part Number	Price €ea.	Description	Req.	Details
Bonnet Fittings					
95	14B5777	€58.44	SURROUND ASSEMBLY, air intake	1	
	870-120	€58.44	GRILLE, air intake	1	BN4, BN6, BN7/BT7 to
					(c)13750
96	031-349	€58.44	GRILLE, air intake	1	BN7/BT7 from (c)13751,
					BJ7, BJ8
98	GHF206	€1.32	NUT	3	
99	NA		WASHER, plain	3	
100	GHF331	€0.84	WASHER, locking	3	
101	NA		WASHER, packing	3	
105	031-314	€62.52	BONNET HINGE, RH	1	
	031-313	€62.52	BONNET HINGE, LH	1	
107	GHF117	€0.72	BOLT, hinge	4	
108	GHF200	€0.96	NUT	4	
109	GHF300	€1.08	WASHER, plain	8	
110	GHF331	€0.84	WASHER, locking	4	
111	805-405	NA	PIN, clevis	2	
112	GHF301	€0.60	WASHER, plain	4	
113	NA		WASHER, anti-rattle	4	
115	NA		SAFETY CATCH ASSY, hood	2	
116	14A366	€18.72	SAFETY CATCH, with pin & spring	2	
117	NA		BRACKET, mounting	2	
120	NA		ROD, bonnet prop	1	BN4 to C.E.68959
	804-560	€72.84	ROD, bonnet prop	1	except BN4 to C.E.68959
121	682-200	€0.84	GROMMET, rubber	1	
122	GHF301	€0.60	WASHER, plain	1	
123	2H9215	€2.40	RUBBER CLIP, bonnet prop rod	1	
124	GHF504	€1.08	SPLIT PIN	1	
130	NA		STRIKER PIN ASSEMBLY	1	
131	FPQ10001	€3.72	SPRING, striker pin	1	
132	14A6586	€10.56	STRIKER PIN	1	
133	ADA458	€15.48	CUP	1	
134	470-612	€69.48	BASE PLATE	1	
135	SH604051	€0.72	SCREW, striker pin assembly	2	
136	GHF300	€1.08	WASHER, plain	4	
137	GHF331	€0.84	WASHER, locking	4	
138	805-435	€80.76	BRACKET, bonnet latch support	1	
139	SE910201	€1.08	SCREW, bracket to body	2	
140	GHF306	€0.72	WASHER, plain	8	
141	GHF331	€0.84	WASHER, locking	2	
144	AAM1223	€8.28	PLATE, guide	1	
145	ADA464	€2.76	TUBE, distance	2	
146	ADA461	€46.68	SLIDER, bonnet catch	1	
147	ADH456	€28.80	SLIDER SUPPORT ASSEMBLY	1	
148	NA		BOLT, plate tube and slider	2	
152	805-255	€50.04	ROD, bonnet latch remote control	1	
153	031-777	€1.08	GROMMET, front support bracket	1	
154	RFN403	€1.80	GROMMET, rear	1	
155	329-265	€3.60	SPRING, anti-rattle	1	
157	NA		BRACKET, anchor	1	
158	14G5507	€0.84	CLIP, retaining, anchor bracket	1	BJ7 & BJ8
161	ADA3669	€10.08	LEVER	1	
162	NA		CLEVIS PIN, lever	1	
163	PWZ203	€0.96	WASHER, plain, large	2	
166	14B6745	€25.44	ROD, connecting, lever to slider	1	
170	ADA466	€9.12	SPRING, tension, hood latch	1	
171	ADA467	€2.52	SLEEVE, spring	1	
174	805-445	€11.16	BRACKET, rod support, front	1	
175	PMZ308	€0.72	SCREW, bracket	1	BN4, BN6, BN7,
176	GHF206	€1.32	NUT	1	BT7, BJ7
177	GHF306	€0.72	WASHER, plain	2	
178	GHF331	€0.84	WASHER, locking	1	
180	NA		BRACKET, rod support, rear	1	BJ8
181	NA		SCREW, self tapping	2	

Engine Bay Fittings

182	CRCP313	€9.48	PLATE, chassis ID	1	BN4 (Longbridge)
183	CRCP312	€7.32	PLATE, chassis ID	1	BN4 (Abingdon) - most BJ8
184	CRCP379	€8.40	PLATE, chassis ID	1	very late BJ8
185	NA		PLATE, pedal box blanking	1	
186	AB608031	€1.08	SCREW, fixing plate	4	
187	NA		NUT, spire	4	
188	NA		PLATE, steering column sealing, inner	1	
189	NA		PLATE, steering column sealing, outer	1	
190	NA		PLATE, steering column blanking, inner	1	
191	NA		PLATE, steering column blanking, outer	1	
192	805-455	NA	FELT, sealing and blanking plates	4	
193	AB606031	€0.84	SCREW, plate	16	
194	NA		WASHER, special	16	
195	NA		BRACKET, steering column	1	BN4, BN6, BN7, BT7
	NA		BRACKET, steering column	1	BJ7, BJ8
196	SH605051	€1.80	SCREW, bracket	4	
197	GHF201	€0.84	NUT	4	
198	GHF301	€0.60	WASHER, plain	8	
199	GHF332	€0.84	WASHER, locking	4	
200	NA		BRACKET, steering column steady	1	
202	NA		BRACKET, steering column mount	1	BJ8 LHD
	NA		BRACKET, steering column mount	1	BJ8 RHD
	NA		BRACKET, steering column mount	1	BJ8
203	GHF201	€0.84	NUT	1	
204	GHF301	€0.60	WASHER, plain	2	
205	GHF332	€0.84	WASHER, locking	2	
206	681-018	€22.08	GROMMET AND PLUG KIT, firewall	1	(general assortment)

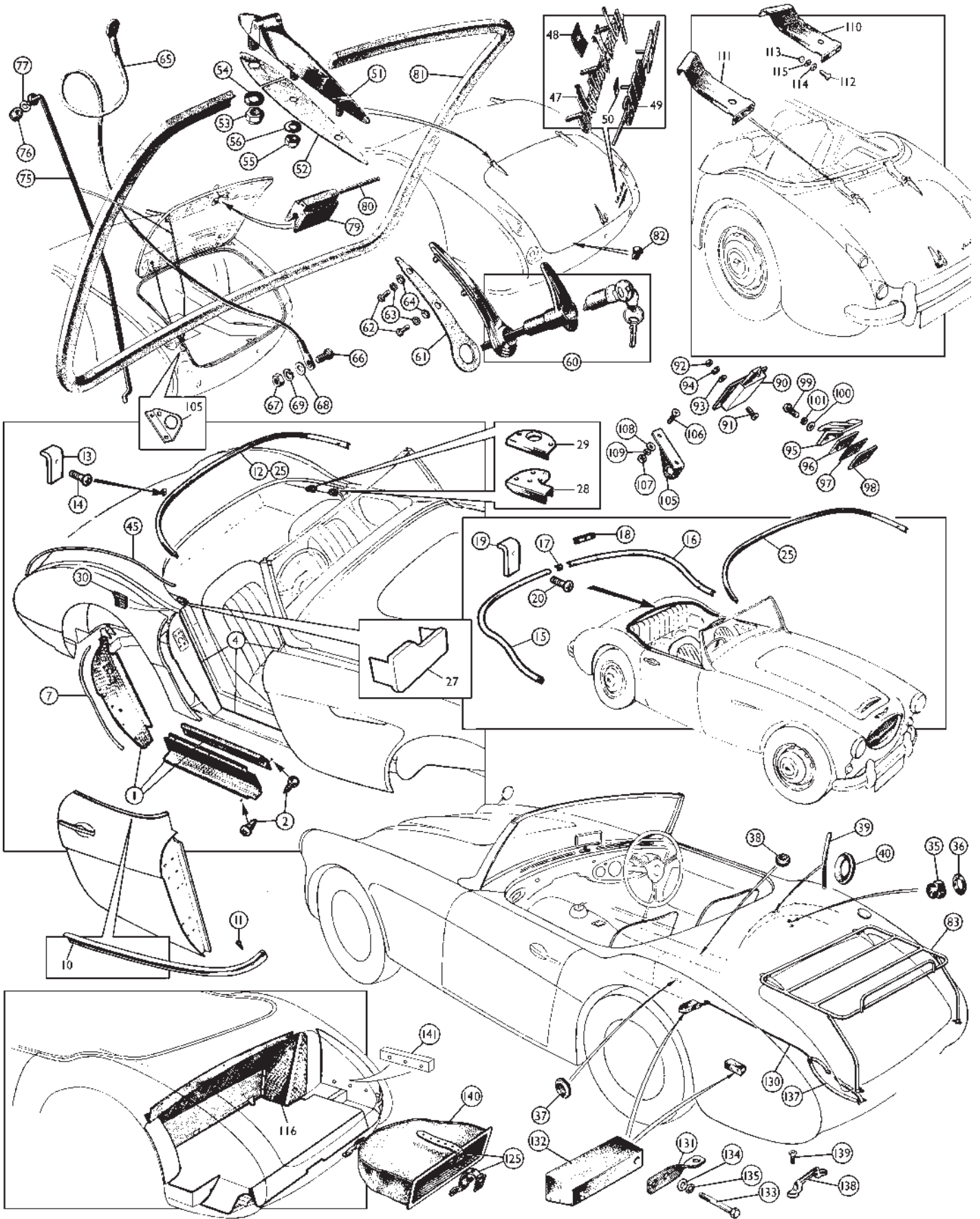

ill.	Part Number	Price €ea.	Description	Req.	Details
Rear Body Fittings 100-6, 3000					
1	802-775	€90.00	SHUT FACE FINISHER SET, RH	1	BN4 to C.E.68959
	802-785	€90.00	SHUT FACE FINISHER SET, LH	1	
	803-820	€118.56	SHUT FACE FINISHER SET, RH	1	BN4 from C.E.68960,
	803-830	€118.56	SHUT FACE FINISHER SET, LH	1	
	MM803-840	€126.84	SHUT FACE FINISHER SET, RH	1	BJ7, BJ8
	MM803-850	€126.84	SHUT FACE FINISHER SET, LH	1	
2	54K3024	€0.96	SCREW, finisher, chromed	A/R	
	725-176	NA	SCREW, finisher, stainless steel	A/R	alternate option
	682-128	NA	RUBBER DOOR SEAL SET	1	BN4 to C.E.68959
4	805-158	€109.56	CHANNEL SET, door seal (6 pieces)	1	(Longbridge cars)
	805-165	NA	CHANNEL, hinge pillar	2	
	805-205	NA	CHANNEL, RH sill	1	
	805-215	NA	CHANNEL, LH sill	1	
	805-175	NA	CHANNEL, latch pillar	2	
7	249-880	€14.40	PIPING, shut pillar finisher, black	1	(for two doors)
10	804-940	€88.92	MOULDING, door top, RH	1	BN4, BN6, BN7,
	804-950	€88.92	MOULDING, door top, LH	1	BT7 (4-seaters)
11	725-180	€0.84	SCREW, moulding	6	
12	804-990	€151.32	MOULDING, rear cockpit	1	BN6, BN7 (2-seaters)
13	804-915	€9.84	PLATE, tapped	5	
14	RMP312	€1.20	SCREW, moulding, 3/4"	4	
		NA	SCREW, moulding, 1"	3	
15	804-960	€153.84	MOULDING, rear cockpit, RH	1	
16	804-970	€153.84	MOULDING, rear cockpit, LH	1	
17	804-980	€11.76	MOULDING, rear cockpit, centre	1	
18	804-905	€15.36	PLATE, joint, centre moulding	1	
19	804-915	€9.84	PLATE, tapped, rear moulding	6/8	BN4, BT7
20		NA	SCREW, moulding, 3/4"	9	
		NA	SCREW, moulding, 5/8"	2	
	GHF206	€1.32	NUT	3	
	GHF306	€0.72	WASHER, plain	3	
	GHF331	€0.84	WASHER, locking	3	
25	804-995	NA	TONNEAU MOULDING, 1-piece	1	BJ7, BJ8 qty reduced
	AD606043	€0.96	SCREW	14/12	from BJ7 (b)57500
27	806-380	€55.08	CAP, shut pillar, RH	1	BN4 to C.E.68959
	806-370	€55.08	CAP, shut pillar, LH	1	
28	021-785	€6.24	CAP, door seal, RH	1	BN4 from C.E.68960 BN6,
	021-784	€6.24	CAP, door seal, LH	1	BN7, BT7
29	021-786	€6.00	PLATE, bow socket finisher	2	BN6, BN7
30	805-210	€50.52	FINISHER, rear quarter panel, RH	1	BJ7, BJ8
	805-220	€50.52	FINISHER, rear quarter panel, LH	1	
31		NA	SCREW	2	
32		NA	SCREW	2	
35	14B2685	€3.72	DOVE NUT, for seat belt	4	
36	GHF301	€0.60	WASHER, plain	4	BN7, BT7, BJ7, BJ8
37		NA	PLUG, blanking safety belt hole in tunnel	2	
38		NA	PLUG, blanking safety belt hole in floor	4	
39	807-045	€9.48	DRAIN TUBE, cockpit water channel	2/3	
40	681-045	€2.40	GROMMET, drain tube	2/3	BJ7, BJ8
	GHC11030	€5.40	CLIP, drain tube	A/R	

*These mouldings are supplied polished and slightly over-length. They must be trimmed to fit your particular car, and may be clear anodized locally.

Rear Outer Body and Boot Lid Fittings

45	14B1708	€48.36	BEADING, rear wing	2	
47	8G705	€18.12	BADGE, 'Austin Healey'	1	
48	PFS106	€0.72	FIXING, badge	3	
49	AHB8861	€17.04	MOTIF, '3000'	1	BN7, BT7, BJ7, BJ8
50	326-510	€0.96	FIXING, badge	2	
51	14B1726	€67.80	BOOT HINGE, LH	1	Will not work with factory style luggage racks car set
	14B1725	€67.80	BOOT HINGE, RH	1	
52	14B3462K	€5.40	GASKET SET, boot hinge	1	
53	GHF272	€1.20	NUT, hinge to body	2	
54	GHF300	€1.08	WASHER, plain	2	
55	GHF271	€0.84	NUT, hinge to boot lid	4	
56	GHF301	€0.60	WASHER, plain	4	
60	14B1963	€67.80	BOOT HANDLE, with lock and 2 keys	1	
61	14B1964	€1.80	GASKET, boot handle	1	
62	PMZ306	€1.08	SCREW	2	
63	WL700101	€1.20	WASHER, shakeproof	2	
64		NA	WASHER, cup	2	
65	14B8692	€33.60	CABLE, boot lid control	1	
66	SE604051	€0.84	SCREW	1	
67	GHF200	€0.96	NUT	1	
68	GHF300	€1.08	WASHER, plain	1	
69	GHF331	€0.84	WASHER, locking	1	
75	804-540	€26.64	PROP ROD, boot lid	1	
76	682-200	€0.84	GROMMET, rod	1	
77	GHF301	€0.60	WASHER, plain	1	
79	2H9215	€2.40	RUBBER CLIP, prop rod	1	
80	GHF504	€1.08	SPLIT PIN	1	
81	SC208	€32.16	BOOT SEAL	1	
			(glued on boot lid, larger rounded lip to outside)		
82	4G8595	€1.80	BUFFER, boot lid	3	
83	17H9932	€408.00	LUGGAGE RACK	1	requires OE trunk hinges

Internal Boot Fittings

90	14B1718	€71.16	LATCH	1	
91	SF604061	€0.96	SCREW, fixing lock	4	

ill.	Part Number	Price €ea.	Description	Req.	Details
92	GHF200	€0.96	NUT	4	
93	GHF300	€1.08	WASHER, plain	4	
94	GHF331	€0.84	WASHER, locking	4	
95	14B1719	€50.52	STRIKER, boot lid	1	
96	806-885	NA	PLATE, packing	A/R	
97	807-005	NA	PACKING PIECE	1	
98		NA	PLATE, tapped	1	
99		NA	SCREW, fixing striker	3	
100	GHF300	€1.08	WASHER, plain	3	
101	GHF331	€0.84	WASHER, locking	3	
105	804-925	€8.52	BRACKET, stay, prop rod	1	
106	CMZ305	€1.20	SCREW, fixing bracket	2	
107	GHF206	€1.32	NUT	2	
108		NA	WASHER, plain	2	
109	GHF331	€0.84	WASHER, locking	2	
110	806-845	€37.92	BRACKET, reinforcement, RH	1	
111	806-855	€37.92	BRACKET, reinforcement, LH	1	
112	CMZ305	€1.20	SCREW, fixing bracket	4	BN4, BT7
113	GHF206	€1.32	NUT	4	
114	GHF306	€0.72	WASHER, plain	4	
115	GHF331	€0.84	WASHER, locking	4	
116	14B8708	€10.80	PANEL, fuel pipe cover, black	1	
117		NA	SCREW, fuel pipe cover panel	6	
118		NA	RIVET, rear axle cover panel	6	BN4, BT7, BJ7, BJ8
119		NA	WASHER, plain	6	
120		NA	PLUG, blanking, boot axle cover	1	
125	221-675	€83.40	STRAP ASSEMBLY, spare tyre	1	
126	RMP310	€1.44	SCREW	4	
127	GHF306	€0.72	WASHER, plain	4	BN6, BN7
128	GHF331	€0.84	WASHER, locking	2	
129	GHF206	€1.32	NUT	2	
130	221-650	€35.40	ROD, retaining spare wheel	1	
131	221-665	€13.20	BRACKET, rod	1	
132	221-640	€20.04	BLOCK, spare wheel	2	
133	BH604221	€1.44	BOLT, block to body	4	
134	GHF300	€1.08	WASHER, plain	4	BN4, BT7, BJ7, BJ8
135	GHF331	€0.84	WASHER, locking	4	
136		NA	SCREW, wood	1	
137	14B6771	€42.48	STRAP, securing spare wheel	1	
138	2K9579	€7.56	STAPLE, chrome, strap retaining	1	
139	RMP310	€1.44	SCREW, chrome, staple to floor	2	
140	249-940	€165.72	SPARE TYRE COVER, black	1	
	249-950	€159.00	SPARE TYRE COVER, red	1	BN6, BN7
	249-960	€168.96	SPARE TYRE COVER, blue	1	

Included in BN6 & BN7 carpet kits listed on page 142.

141	031-411	€22.32	BATTERY SUPPORT, 3/4" thick	1	thru BJ8 (b)76138
	031-423	€33.12	BATTERY SUPPORT, 3" thick	1	BJ8 from (b)76139

Boot Liner Kits

Dress up your boot with one of our "tailored to your car" boot liner sets. Available in black only.

249-930	€256.80	BN4 & BT7
249-920	€457.20	BN6 & BN7
249-930	€256.80	BJ7 & BJ8

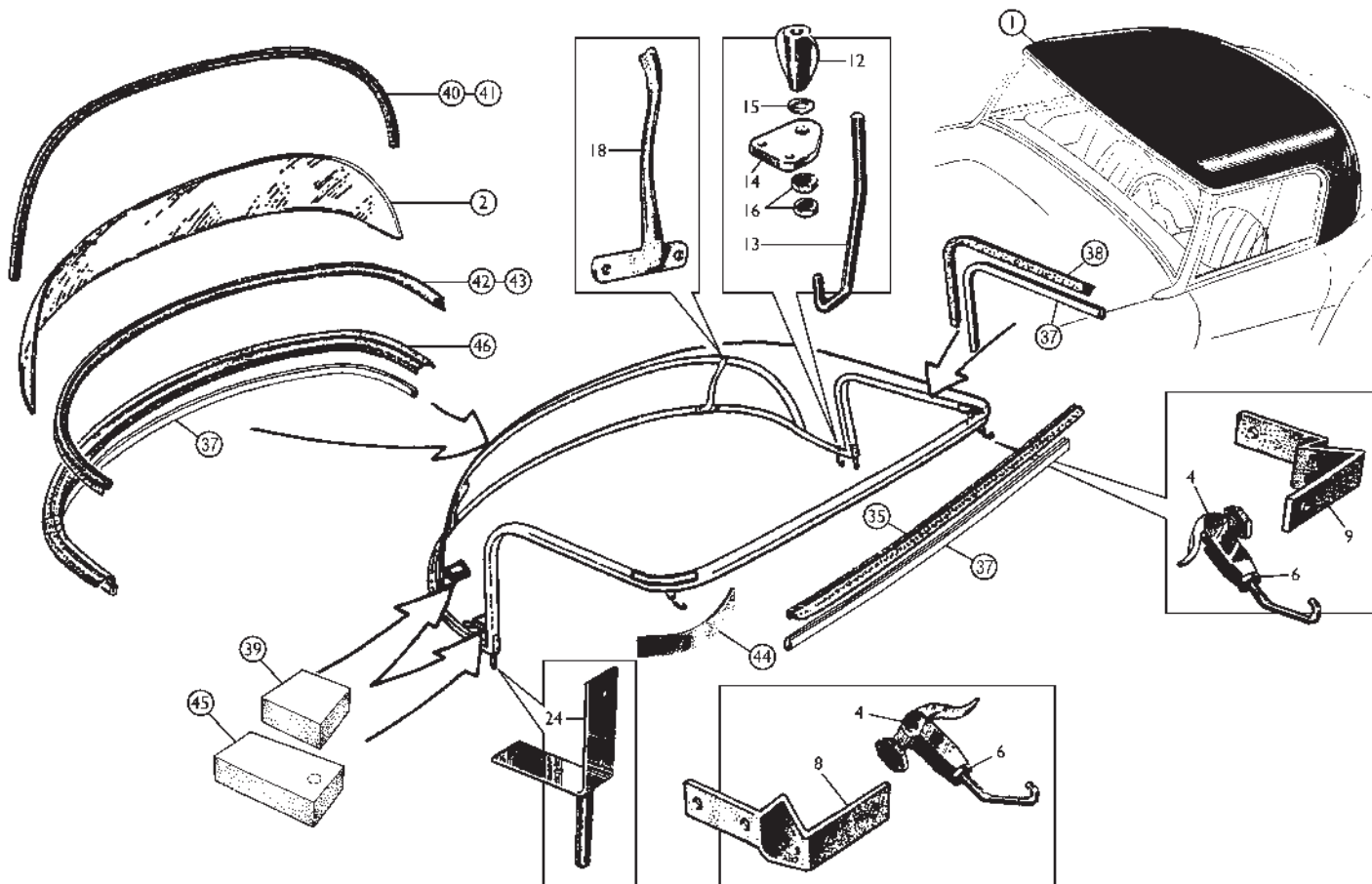

Part Number	Price €ea.	Description	Req.	Details
Hardtops 100-6, 3000				
Hardtop BN4, BN6, BN7, BT7				
1		NA HARD TOP ASSEMBLY	1	BN4, BT7 (4 seat)
		NA HARD TOP ASSEMBLY	1	BN6, BN7 (2 seat)
2	021-862 €555.60	SCREEN, rear, hardtop	1	BN4, BT7
	021-863 €510.00	SCREEN, rear, hardtop	1	BN6, BN7
	021-864 €554.40	SCREEN, rear, hardtop	1	BJ7, BJ8
4	805-028 €151.32	CATCH SET	1	
6		NA NUT	2	
		NA SCREW, catch to corner bracket	4	
8		NA CORNER BRACKET, RH	1	
9		NA CORNER BRACKET, LH	1	
12	805-115	NA WING NUT	2	
13		NA HOOK	2	BN4, BT7
14		NA PLATE	2	
		NA HOOK	2	BN6, BN7
		NA PLATE	2	
15		NA WASHER, plain	2	
16		NA NUT	4	
18		NA PILLAR, support, RH	1	
		NA PILLAR, support, LH	1	
AJD2246	€1.32	SCREW, support pillar to cockpit rail	4	
		NA WASHER, chrome	4	
PMZ314	€0.72	SCREW, support pillar to backlight glazing channel	2	BN4, BT7
24		NA SPIGOT, locating, RH	1	
		NA SPIGOT, locating, LH	1	
		NA TUBE, for spigot	2	
		NA CHANNEL, backlight glazing	1	
35		NA SEAL, header rail	1	
021-890	€1,008.00	SEAL SET, hardtop (includes 1x header rail seal, 1x windlace seal, 1x hardtop to cockpit rail seal)	A/R	BN4, BT7
36		NA CLIP, securing seal	A/R	
37	021-838	NA WINDLACE SET, off-white (4 pc.)	1	BN4 & BT7
	021-848	NA WINDLACE SET, off white (3 pc.)	1	BN6 & BN7
38		NA CANTRAIL SEAL	2	
39		NA PAD, rear wing to hard top	A/R	
40		NA SEAL, backlight glazing	1	top
41		NA FILLER STRIP, backlight glazing seal	1	top
42		NA SEAL, backlight glazing	1	bottom
43		NA FILLER STRIP, backlight glazing seal	1	bottom
44		NA BUFFER	2	
45		NA PAD, cockpit rail sealing	2	BN4, BT7

Part Number	Price €ea.	Description	Req.	Details
46		NA PAD, cockpit rail sealing	2	BN6, BN7
		NA SEAL, hardtop to cockpit rail	1	BN4, BT7
		NA SEAL, hardtop to shroud	2	BN6, BN7
		NA PACKING STRIP, cockpit rail, wide	1	BN4, BT7
		NA PACKING STRIP, cockpit rail, narrow	1	
		NA SECURING STRIP	1	BN6, BN7
		NA SCREW, securing seal	A/R	
		NA CLIP, securing seal	A/R	
Hardtop BJ7, BJ8				
021-795		NA HARD TOP ASSEMBLY	1	
021-864	€554.40	BACKLIGHT	1	
		NA CHANNEL, backlight glazing	1	
		NA HARDTOP SEAL SET (includes header rail seal, cant rail seal, glazing seals, cockpit rail seal)	1	
021-890	€1,008.00	SEAL SET, hardtop (includes 1x header rail seal, 1x windlace seal, 1x hardtop to cockpit rail seal)	A/R	BN4, BT7

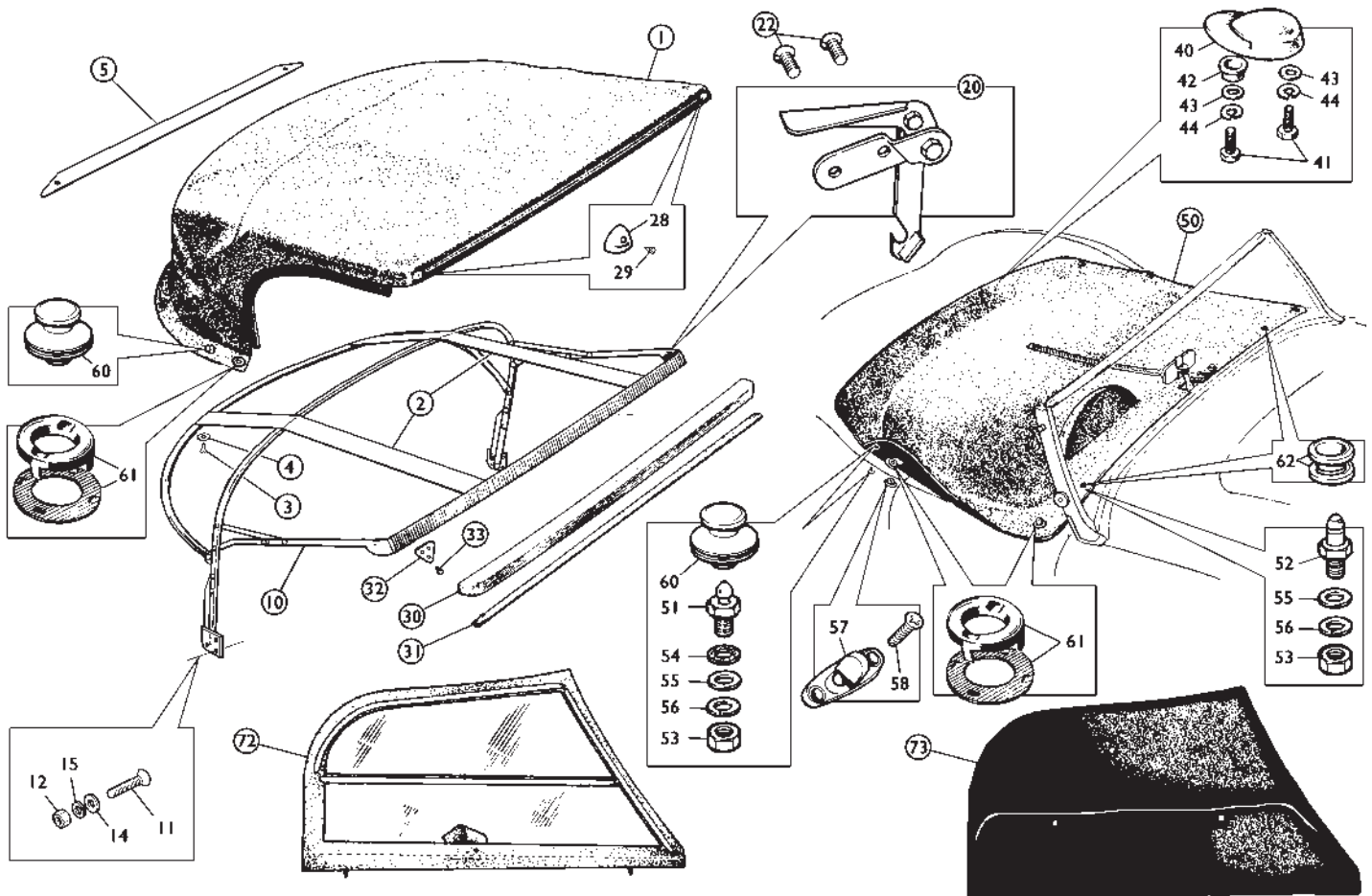

iii. Part Number Price €ea. Description Req. Details

Weather Equipment BN1, BN2

1			See pages 146-147 for complete Hood listings.	
2	641-008	€8.52	WEBBING SET, hood frame (grey)	1
3	NA		SCREW	4
4	CD24152	€1.08	WASHER	4
5	644-200	€23.04	HOOD ANCHOR BAR, rear	1
10	453-670	€375.60	HOOD FRAME ASSEMBLY	1
11	SF605081	€1.08	SCREW, frame to inner quarter panel	6
12	GHF201	€0.84	NUT	6
14	GHF301	€0.60	WASHER, plain	6
15	GHF332	€0.84	WASHER, locking	6
20	804-988	€96.96	CLAMP SET (pair)	1
22	NA		SCREW, clamp to header rail	4
28	AKE1762CAP	€4.20	FINISHER, header rail	2
29	NA		SCREW, finisher to header rail	2
30	MM021-580	€22.20	HEADER RAIL, wood	1
31	682-345	€28.92	HEADER RAIL SEAL (original type)	1
	682-350	€19.68	HEADER RAIL SEAL (replacement)	1
32	644-205	€10.80	RETAINER, header rail	3
33	4G8595	€1.80	BUFFER, header rail	3
40	14B1730	€7.56	RETAINER, 'teardrop', on shroud	2
41	PMZ305	€0.84	SCREW, mounting to shroud	4
42	AAA5130	€5.88	WASHER, cup	2
43	GHF306	€0.72	WASHER, plain	4
44	GHF331	€0.84	WASHER, locking	4
50			See page 148 for complete Tonneau Cover listings.	
51	TFP1006	€1.56	STUD, 'Tenax'	4/6
52	97H717	€1.80	STUD, 'Lift-the-Dot', for windscreen spring	2
53	GHF206	€1.32	NUT, for studs	A/R
54	2K4936	€0.72	WASHER, leather, paint protecting	5/7
	315-168	€5.64	WASHER SET, nylon (pack of 10)	A/R alternative to leather washer
55	GHF306	€0.72	WASHER, plain	5/7
56	GHF331	€0.84	WASHER, locking	5/7
57	14A6536	€2.40	TURN BUTTON, silver	2/4
58	AD604043	€1.20	SCREW, turn button	4/8
60	TFS106	€4.44	FASTENER ASSEMBLY, 'Tenax'	A/R genuine "Tenax" brand
61	14A6537S	€1.44	EYELET AND WASHER, turn button	A/R
62	802-358	€1.20	SAIL EYELET & WASHER	2
72	259-108†	€904.80	SIDE SCREEN SET, black	1
	259-118†	€904.80	SIDE SCREEN SET, blue	1

iii. Part Number Price €ea. Description Req. Details

259-138†	€904.80	SIDE SCREEN SET, red	1
	NA	SIDE SCREEN SET, green	1
	NA	SIDE SCREEN SET, white	1
73 248-930†	€83.76	SIDE SCREEN STOWAGE BAG, black	1
	NA	SIDE SCREEN STOWAGE BAG, blue	1
	NA	SIDE SCREEN STOWAGE BAG, red	1

†Note: Side screens supplied are the original type for BN1 from body #7258 and BN2, and will fit earlier cars. Earlier style side screens are not available.

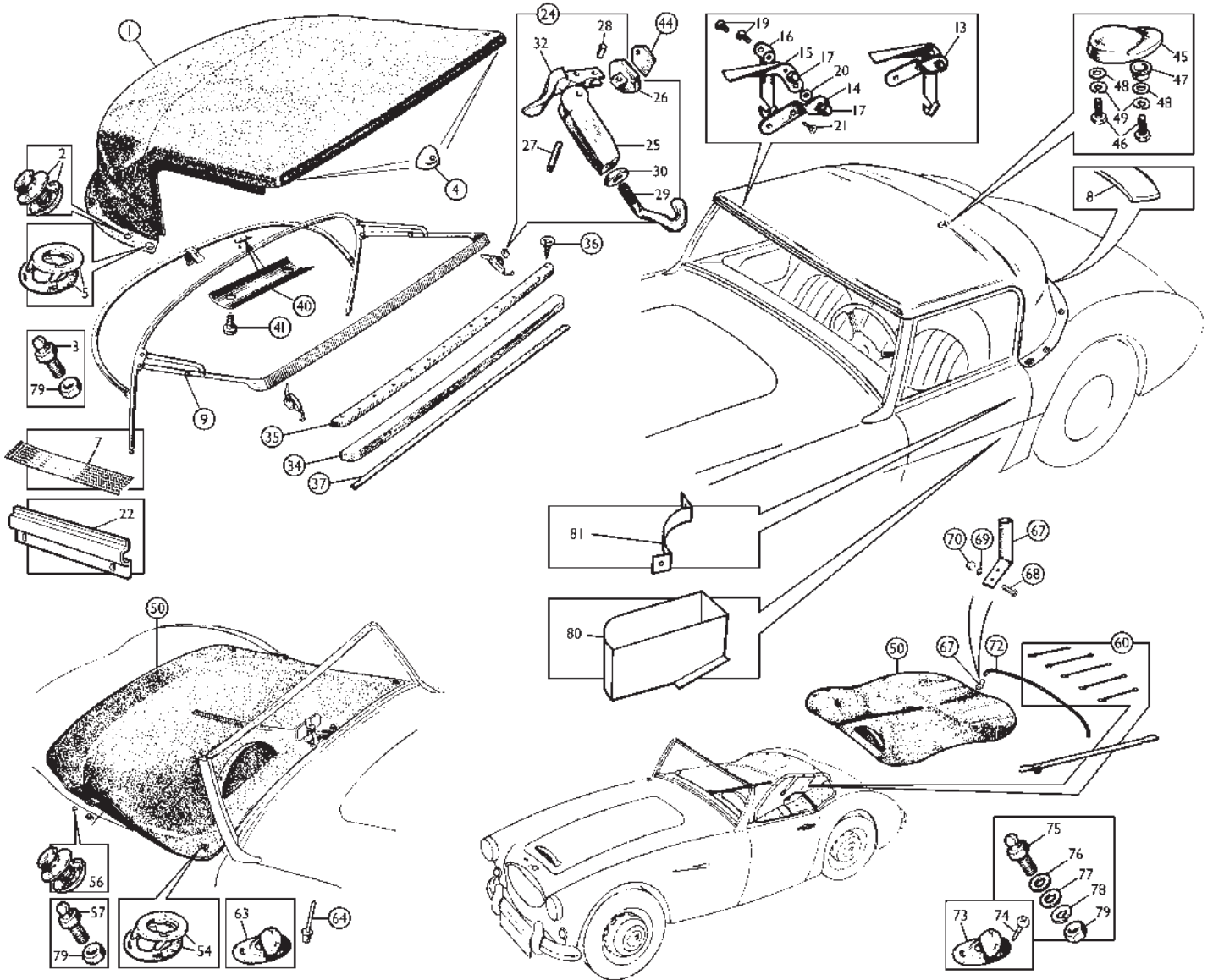

ill.	Part Number	Price €ea.	Description	Req.	Details
Weather Equipment BN4, BN6, BN7, BT7					
1			HOODS See pages 146-147 for complete hood listings		
2	TFS106	€4.44	FASTENER, 'Tenax'	12	BN4, BT7
	TFS106	€4.44	FASTENER, 'Tenax'	4	BN6, BN7
3	TFP1006	€1.56	STUD, Tenax	12	BN4, BT7
	TFP1006	€1.56	STUD, Tenax	4	BN6, BN7
4	AKE1762CAP	€4.20	FINISHER, shield shape, at ends of hidem strip	2	
5	14A6537S	€1.44	EYELET & WASHER	2	
7	641-008	€8.52	WEBBING SET (per car)	1	
8	644-210	€33.84	ANCHOR BAR, rear	1	BN6, BN7
9	453-675	€375.60	HOOD FRAME ASSEMBLY	1	BN4 to C.E.68959 (4 seat)
	453-666	NA	HOOD FRAME ASSEMBLY	1	BN4 from C.E.68960, BT7 to C.E.1528 (4 seat)
	453-667	€470.40	HOOD FRAME ASSEMBLY	1	BT7 from C.E.1529 (4 seat)
	SC1619	€399.60	HOOD FRAME ASSEMBLY	1	BN6, BN7 (2 seat)
10		NA	HOOD CLAMP ASSEMBLY	2	BN4 RHD to C.E.28102,
11		NA	HOOK	2	LHD to C.E.28013
12		NA	SET SCREW	2	
13	MM805-008	€94.32	CLAMP SET (pair)	1	
14		NA	PRESSING, top mounting, RH	1	
		NA	PRESSING, top mounting, LH	1	
15		NA	GRIP, finger, RH	1	BN4 RHD from C.E.28103,
		NA	GRIP, finger, LH	1	BN4 LHD from C.E.28014 all BT7
16		NA	LEVER, locking, RH	1	
		NA	LEVER, locking, LH	1	
17		NA	NUT, dome	4	
18		NA	T-NUT	4	
19		NA	SCREW	4	
20		NA	WASHER, special	4	
21		NA	SCREW, latch to header rail	4	
22	805-555	€57.60	SLIDE RAIL, RH	1	BN4 to C.E.68959
	805-565	€61.44	SLIDE RAIL, LH	1	
24	805-028	€151.32	CATCH PAIR	1	
25		NA	BODY	2	
26		NA	FIXING BASE	2	
27		NA	PIN, large	2	
28		NA	PIN, small	2	BN6, BN7
29		NA	HOOK, LH	1	
		NA	HOOK, RH	1	
30		NA	NUT	2	
32		NA	HANDLE, clamp	2	
34	SC1646	€127.68	HOOD BOW, wood	1	
35	806-110	€114.24	RETAINING RAIL	1	BN4, BT7
	806-100	€114.24	RETAINING RAIL	1	BN6, BN7
36		NA	SCREW	15	
37	682-350	€19.68	HOOD SEAL	1	
40		NA	CLIP, top to frame	4	BN4 to C.E.68959
	805-025	€5.16	CLIP, top to frame	2	BN6, BN7, BT7
41	323-445	NA	SCREW	8	BN4 to C.E.68959
	AB606031	€0.84	SCREW	4	BN6, BN7, BT7
42		NA	PACKING, clamp assembly	2	BN4, BT7
43		NA	SCREW	2	
44		NA	PACKING, clamp assembly	2	BN6, BN7
45	14B1730	€7.56	RETAINER, top	2	
46	PMZ305	€0.84	SCREW	4	
47	AAA5130	€5.88	WASHER, cup	2	
48	315-055	€0.72	WASHER, plain	4	
49	GHF331	€0.84	WASHER, locking	4	
50			TONNEAU COVERS, listed on page 148		
54	14A6537S	€1.44	EYELET & WASHER	9	BN4, BT7
	14A6537S	€1.44	EYELET & WASHER	4	BN6, BN7
56	TFS106	€4.44	FASTENER, 'Tenax'	13	BN4, BT7
	TFS106	€4.44	FASTENER, 'Tenax'	5	BN6, BN7
57	TFP1006	€1.56	STUD, Tenax	13	BN4, BT7
	TFP1006	€1.56	STUD, Tenax	5	BN6, BN7
60	MM453-658	€79.56	STIFFENER SET	1	
63	14A6536	€2.40	TURN BUTTON, single	5	BN4, BT7
64		NA	RIVET	10	
65		NA	MOUNTING PLATE ASSEMBLY, hood stop	1	
66	2H9215	€2.40	RUBBER STOP, LH side	1	
67	805-575	€25.44	BRACKET, tonneau rail, RH	1	BN4 to C.E.68959 (with sliding & folding top frame)
	805-585	€25.44	BRACKET, tonneau rail, LH	1	
68	PMZ307	€1.20	SCREW	4	
69	315-055	€0.72	WASHER, plain	4	
70	311-046	€1.20	DOME NUT, deep	4	
72	453-645	€45.84	RAIL, tonneau support (44.5")	1	
	AHB8395	€50.16	RAIL, tonneau support (46.5", 1 pc.)	1	
	453-661	NA	RAIL, tonneau support, 2-pc.	1	BN4 from C.E.68960, BT7
73	14A6536	€2.40	TURN BUTTON, silver	2	
74		NA	SCREW, turn button	4	
75	TFP1006	€1.56	STUD, 'Tenax'	12	BN4, BT7
	TFP1006	€1.56	STUD, 'Tenax'	4	BN6, BN7
76	2K4936	€0.72	WASHER, leather	12	BN4, BT7
	2K4936	€0.72	WASHER, leather	4	BN6, BN7
	315-168	€5.64	WASHER SET, nylon (pack of 10)	A/R	alternative to leather washer
77	GHF306	€0.72	WASHER, plain	12	BN4, BT7
	GHF306	€0.72	WASHER, plain	4	BN6, BN7
78	GHF331	€0.84	WASHER, locking	12	BN4, BT7
	GHF331	€0.84	WASHER, locking	4	BN6, BN7
79	GHF206	€1.32	NUT	12	BN4, BT7
	GHF206	€1.32	NUT	4	BN6, BN7

ill.	Part Number	Price €ea.	Description	Req.	Details
80	805-750	€55.92	STOWAGE BOX RH, untrimmed	1	BN6, BN7
	805-760	€55.92	STOWAGE BOX LH, untrimmed	1	
81	805-770	€33.60	STRAP, hood frame, untrimmed	2	

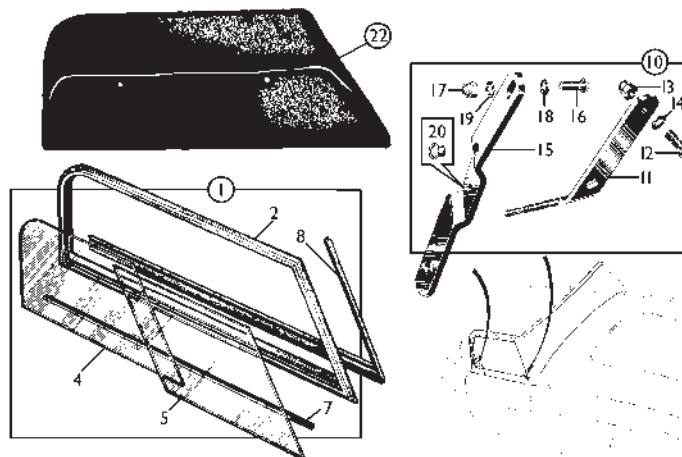

Side Screens, BN4 to BT7

For side screens brackets mounted on doors, see pages 124-125.

1	24B635/6	€462.00	SIDE SCREEN SET	1	BN4 thru C.E.47703
	259-212	€627.60	SIDE SCREEN SET	1	BN4 from 47704 thru BT7
2		NA	FRAME, RH	1	
		NA	FRAME, LH	1	
3		NA	BUFFER, frame	2	
4		NA	WINDOW, sliding, RH	1	
		NA	WINDOW, sliding, LH	1	
5		NA	WINDOW, fixed, pair	1	
6		NA	SLIDE	2	
7		NA	CHANNEL FELT	2	
8	MM021-774	€36.60	SIDE SCREEN STRIP	1	
10	805-038	€55.08	BRACKET SET, side screen fitting	1	BN4 from 47704 - BT7
11		NA	BRACKET, securing, front, RH	1	
		NA	BRACKET, securing, front, LH	1	
12		NA	SCREW, bracket to frame	4	
13		NA	DOME NUT	4	
14	WL700101	€1.20	WASHER, shakeproof	4	
15		NA	BRACKET, securing, rear, RH	1	BN4 from 47704 - BT7
		NA	BRACKET, securing, rear, LH	1	
16		NA	SCREW, bracket to frame	4	
17		NA	DOME NUT	4	
18		NA	WASHER, plain	4	
19	WL700101	€1.20	WASHER, shakeproof	4	
20	4G8595	€1.80	BUFFER, rear securing bracket	2	
22	AHB5483	€76.20	SIDE SCREEN STOWAGE BAG, black	1	

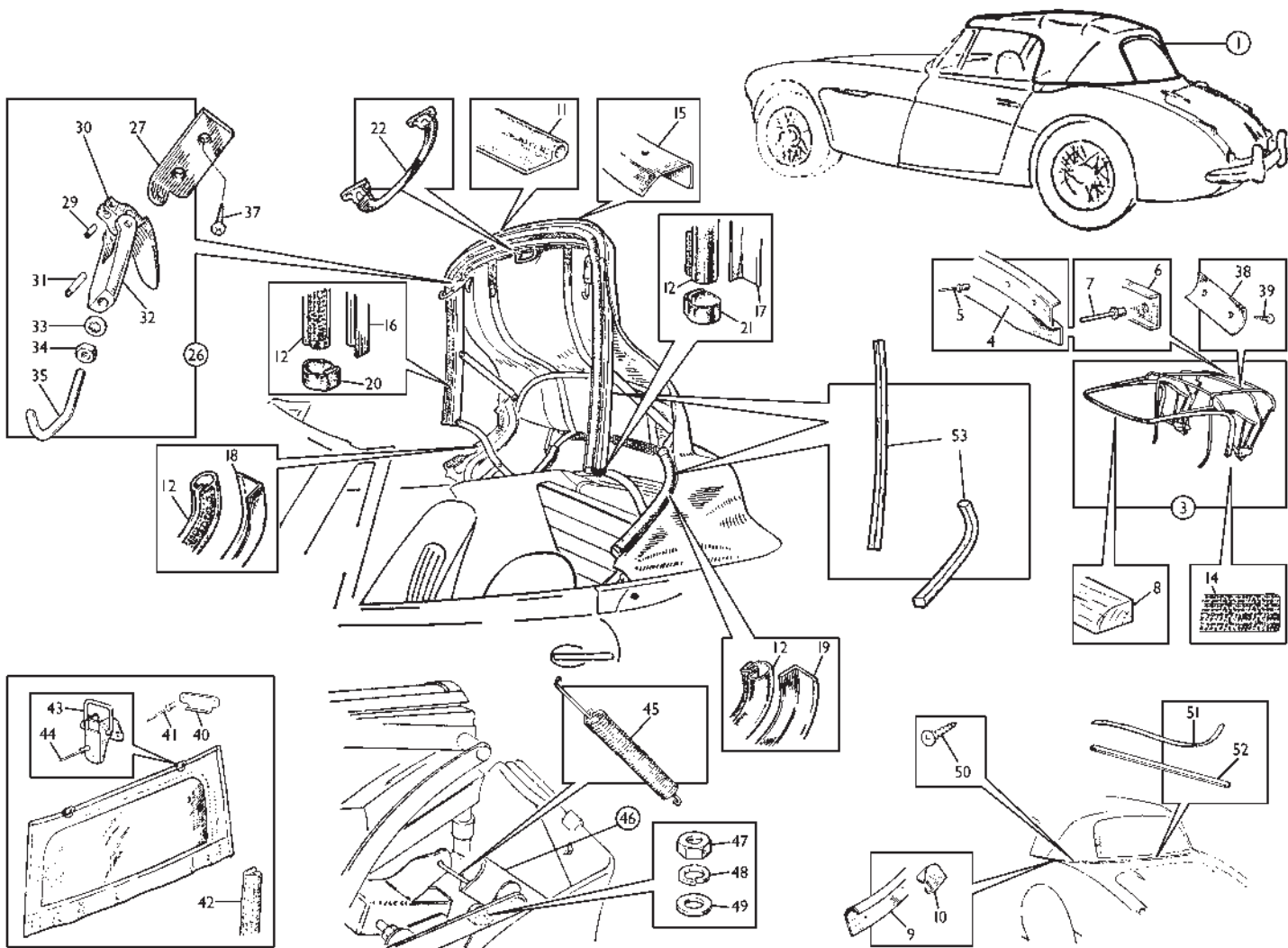

Ill.	Part Number	Price €ea.	Description	Req.	Details
Weather Equipment BJ7, BJ8					
1			HOODS		
			See pages 146-147 for complete hood listings		
3	453-655	NA	HOOD FRAME ASSEMBLY	1	
4		NA	TRIM RAIL, upper	1	BJ7 to (b)59371
5		NA	RIVET	10	
6	806-195	€31.44	TRIM RAIL, upper	1	BJ7 from (b)59372, BJ8
7	GHF600	€0.84	RIVET	8	
8	806-090	€166.56	HEADER RAIL	1	
9	806-735	€112.08	TRIM RAIL, rear (2-piece, steel)	1	
10	GHF1500	€0.84	CLIP, canopy to rear trim rail	36	
11	682-360	€13.32	SIDE SCREEN, front	1	
12	259-850	€290.40	SEAL SET, hood frame, grey	1	as original
	724031M	€10.20	SEAL, hood frame, black, replacement	4	sold per yard
14	641-008	€8.52	WEBBING SET, grey	1	
15	806-115	€84.48	RETAINER, header rail seal	1	
	806-198	€143.76	RETAINER SET, cantrail seals	1	
16		NA	RETAINER, side cantrail seal, RH	1	
17		NA	RETAINER, side cantrail seal, LH	1	
18		NA	RETAINER, rear cantrail seal, RH	1	
19		NA	RETAINER, rear cantrail seal, LH	1	
20	AHB9788	€2.16	END CAP, RH	3	
21	AHB9789	€2.16	END CAP, LH	3	
22	650306	€27.00	HANDLE, header rail	1	
26	805-068	€100.32	CLAMP SET	1	
27		NA	BASE, RH	1	
		NA	BASE, LH	1	
29		NA	PIN, base to clamp	2	
30		NA	LEVER, locking	2	
31		NA	PIN, lever to body	2	
32		NA	BODY	2	
33	WL700101	€1.20	WASHER, shakeproof	2	
34	311-635	€2.40	NUT, chromed	2	
	311-636	NA	NUT, stainless steel, alternate	2	not incl. with clamp set
35	805-308	€27.12	HOOK PAIR	1	
37		NA	SCREW	4	
38	805-025	€5.16	CLIP, web retaining	2	
39	AB606031	€0.84	SCREW	4	

Ill.	Part Number	Price €ea.	Description	Req.	Details
40		NA	CATCH, window toggle fastener	2	
41		NA	RIVET	4	
42		NA	CLOSURE, upper trim rail	1	BJ7 to (b)59371
43	401-685	NA	FASTENER, zinc plated	2	
44		NA	RIVET	4	
45	805-010	€13.56	SPRING	2	
46	805-015	€5.28	COVER, spring	2	
47	GHF201	€0.84	NUT	6	
48	GHF301	€0.60	WASHER, plain	6	
49	GHF332	€0.84	WASHER, locking	6	
50		NA	SCREW, hood to wheelarch	10	
51		NA	SEAL, hood to water channel	A/R	BJ7 to (b)59371
52		NA	SEAL, hood to water channel	1	BJ7 from (b)59372, BJ8
53	806-098	€159.84	WOOD STRIP SET (4 pieces)	1	

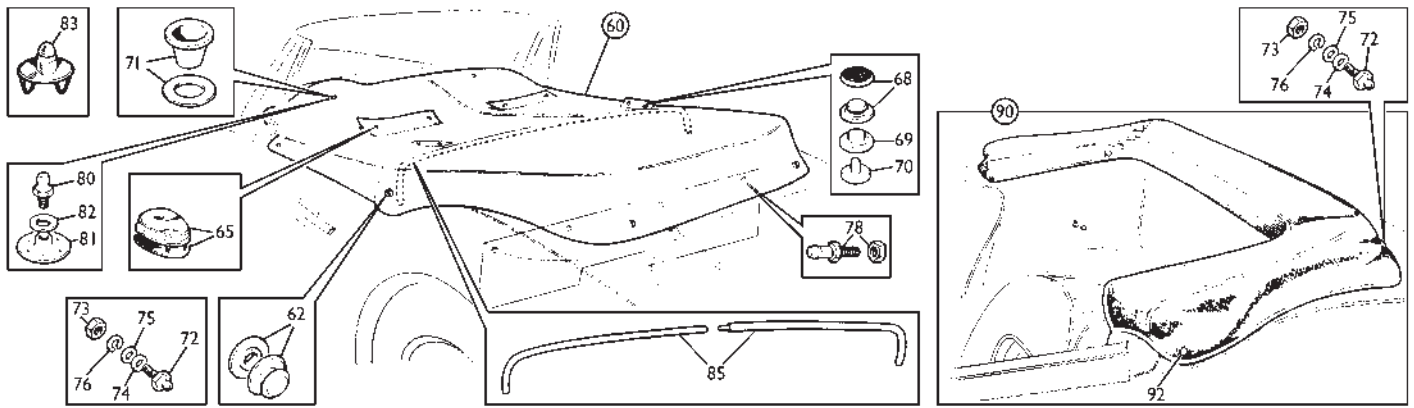

iii. Part Number Price €ea. Description Req. Details

Weather Equipment BN1, BN2

60	NA	TONNEAU COVER, black	1	RHD
	NA	TONNEAU COVER, blue	1	
	NA	TONNEAU COVER, grey	1	
	NA	TONNEAU COVER, red	1	
	NA	TONNEAU COVER, white	1	
AHB9821	€442.80	TONNEAU COVER, black vinyl	1	LHD see pg. 146 for more
AHB9820	€442.80	TONNEAU COVER, blue vinyl	1	
	NA	TONNEAU COVER, grey vinyl	1	
643-065	€442.80	TONNEAU COVER, red vinyl	1	
643-060	NA	TONNEAU COVER, white vinyl	1	
643-061	€811.20	TONNEAU COVER, black stayfast	1	
643-062	€849.60	TONNEAU COVER, blue stayfast	1	
643-063	€948.00	TONNEAU COVER, tan stayfast	1	

Tonneau covers include hardware, but it is not installed so you can get a perfect fit.

62	TFS106	€4.44	FASTENER, 'Tenax'	4	genuine "Tenax" brand
65	LFS100S	€2.64	FASTENER, 'Lift-the Dot'	10	
68	227-108	€2.16	SNAP ASSY, female	4	
69	610624	€1.20	SNAP, male	4	
70	NA	RETAINER, snap	4		
71	NA	EYELET & RING	2		
72	TFP1006	€1.56	STUD, 'Tenax', cover to shroud	8	
73	GHF206	€1.32	NUT	8	
74	2K4936	€0.72	WASHER, leather	8	
	315-168	€5.64	WASHER, nylon (set of 10)	1	alternative to leather washer
75	GHF306	€0.72	WASHER, plain	8	
76	GHF331	€0.84	WASHER, locking	8	
78	226-708	€2.88	FASTENER, cover to heelboard	4	
80	97H717	€1.80	STUD, Lift-the Dot, cover to door & dash hood	6	
81	NA	T NUT	6	as fitted	
82	NA	WASHER, chrome	4		
83	7H9964K	€2.52	STUD & WASHER	6	
85	021-541	€36.60	SUPPORT RAIL SET, tonneau	1	
90	AHB9804	NA	HOOD STOWAGE COVER, black vinyl	1	BJ7
	643-110	€343.20	HOOD STOWAGE COVER, blue vinyl	1	
	NA	HOOD STOWAGE COVER, grey vinyl	1		
	643-105	€343.20	HOOD STOWAGE COVER, red vinyl	1	BJ8
	643-100	€343.20	HOOD STOWAGE COVER, white vinyl	1	
	AHB6838	NA	HOOD STOWAGE COVER, black vinyl	1	
	AHB6837	NA	HOOD STOWAGE COVER, blue vinyl	1	BJ8 (Stayfast acrylic canvas)
	NA	HOOD STOWAGE COVER, grey vinyl	1		
	643-125	NA	HOOD STOWAGE COVER, red vinyl	1	
	643-120	€698.40	HOOD STOWAGE COVER, white vinyl	1	
	643-091	€1,080.00	HOOD STOWAGE COVER, black	1	
	643-092	€1,080.00	HOOD STOWAGE COVER, blue	1	
	643-093	€1,080.00	HOOD STOWAGE COVER, tan	1	
92	TFS106	€4.44	FASTENER, 'Tenax'	10	genuine "Tenax" brand
93	TFP1006	€1.56	STUD for Tenax fasteners	10	

iii. Part Number Price €ea. Description Req. Details

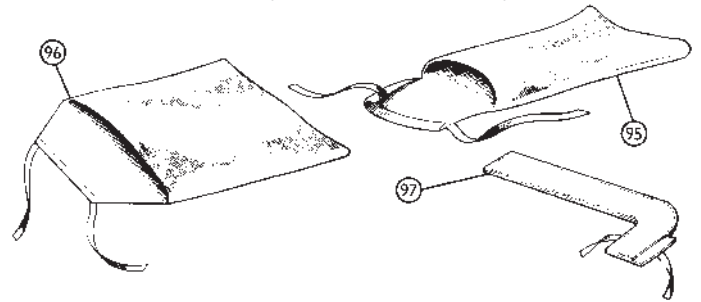

94	GHF206	€1.32	NUT	10
95	641-055	€30.24	STOWAGE BAG, hood stowage cover, black	1
	NA	STOWAGE BAG, hood stowage cover, blue	1	
	NA	STOWAGE BAG, hood stowage cover, red	1	
96	641-075	€39.96	STOWAGE BAG, tonneau, black	1
	641-095	NA	STOWAGE BAG, tonneau, blue	1
	NA	STOWAGE BAG, tonneau, red	1	
97	641-085	€38.28	STOWAGE BAG, tonneau support rails	1

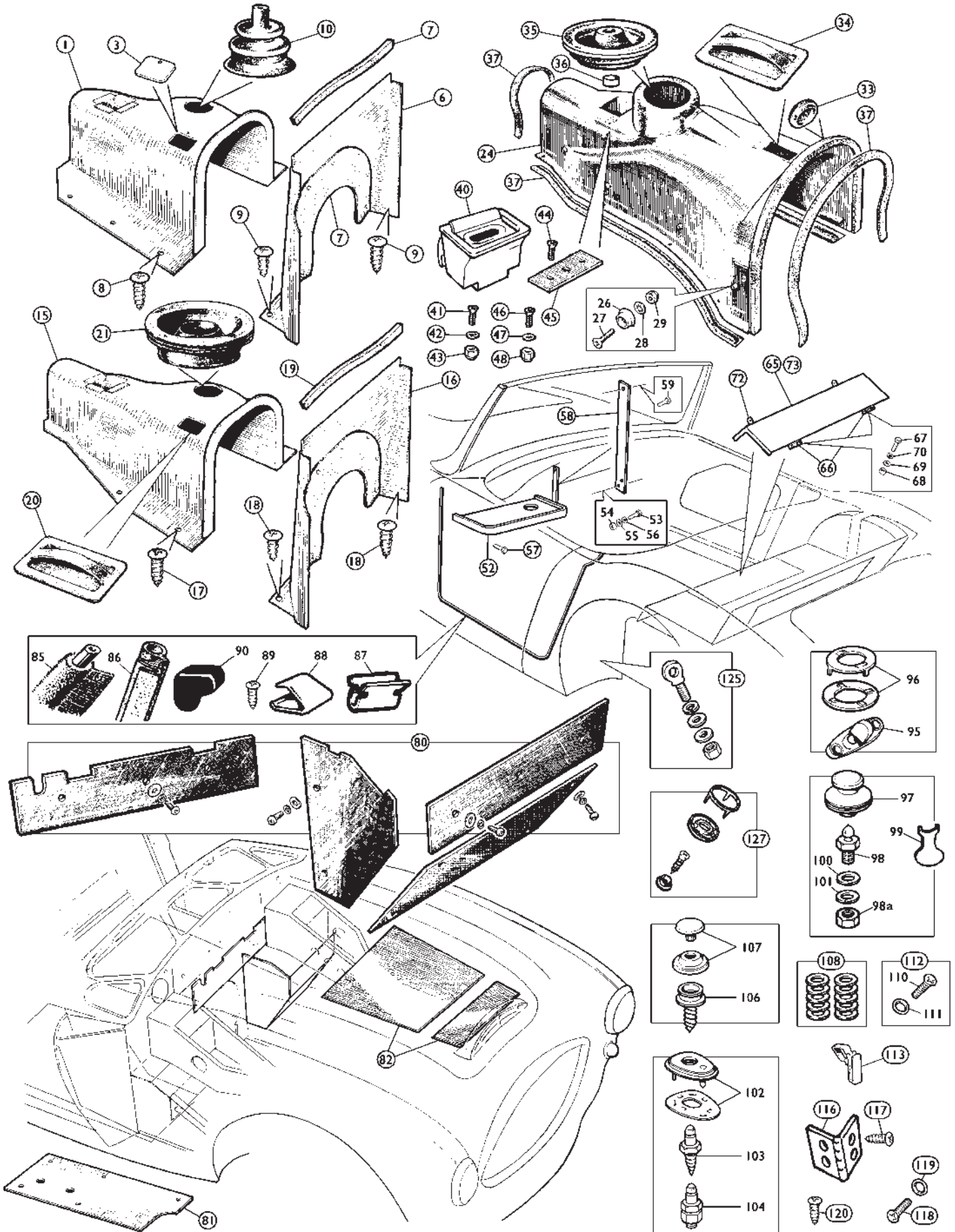

Ill.	Part Number	Price €ea.	Description	Req.	Details
Interior Trim Fittings					
Gearbox Covers					
	NA		GEARBOX COVER	1	BN1
1	NA		SEAL SET, gearbox cover	1	
	NA		GEARBOX COVER	1	
3	NA		SEAL SET, gearbox cover	1	
	NA		OIL FILLER PLATE	1	BN2
	NA		SCREW, securing plate	1	
	NA		ESCUTCHEON	1	
807-095	€101.16		EXTENSION PANEL, gearbox cover	1	BN1
	NA		SEAL SET, extension panel	1	
6 807-105	€110.88		EXTENSION PANEL, gearbox cover	1	BN2
7	NA		SEAL SET, extension panel	1	
8	NA		SCREW, cover & panel to floor	14	
9	NA		SCREW, cover to extension panel	3	BN1, BN2
10 2F3087	€29.76		GAITER, gear lever	1	
	NA		RING, sealing, gear lever grommet	1	BN1 from (b)5746
15 856-430	€278.40		GEARBOX COVER (fiberglass)	1	
681-038	€18.72		SEAL SET, gearbox cover	1	
16 807-115	€115.92		EXTENSION PANEL	1	
17	NA		SCREW, cover and panel to floor	8	BN4, BN6, BN7 to
18	NA		SCREW, extension panel	13	(c)16038, BT7 to (c)15880
19	NA		SEAL, extension panel	1	
20	€3.48		PLUG, gearbox cover	1	
21 4G4920	€10.20		GAITER, gear lever	1	
24 856-440	€318.00		GEARBOX COVER	1	
26 610624	€1.20		SNAP, male	A/R	
27	NA		SCREW	A/R	
28	NA		WASHER, shakeproof	A/R	
29 NH806011	€0.96		NUT	A/R	
30	NA		SCREW, 7/8"	6	
	NA		SCREW, 1"	2	BN7 from (c)16039, BT7
31	NA		WASHER, plain	8	from 15881, BJ7, BJ8
32	NA		GROMMET, tunnel attaching	8	
33 C5574A	€6.60		GROMMET, speedometer cable	1	
34 4G4920	€3.48		PLUG, gearbox cover	2	
35 AHB9510	€11.64		GAITER, gear lever	1	
36 AHH5388	€14.76		CHROME RING, shift lever grommet	1	
37 681-048	€43.32		SEAL SET, gearbox cover	1	

Ashtray

40 14B2016	NA		ASHTRAY ASSEMBLY	1	
41	NA		SCREW, ashtray mount	2	all models except BN1 up
42	NA		NUT	2	to (b)3800
43	NA		WASHER, locking	2	
44	NA		SCREW	2	
45	NA		PLATE, tapped	1	
46	NA		SCREW	1	BN4 thru BJ8
47	NA		WASHER, shakeproof	1	
48	NA		NUT	1	

Parcel Shelves (All models except BJ8)

856-450	€67.32		PARCEL SHELF, uncovered	1	BN1, BN2
52 856-470	€65.64		PARCEL SHELF, LHD, uncovered	1	
	NA		PARCEL SHELF, RHD, uncovered	1	
53 PMP308	€1.32		SCREW	1	BN4, BN6, BN7, BT7, BJ7
54 GHF206	€1.32		NUT	2	
55 GHF306	€0.72		WASHER, plain	2	
56 GHF331	€0.84		WASHER, locking	2	
57 AB608031	€1.08		SCREW, 3/8"	4	BN4, BN6, BN7, BT7
	NA		SCREW, 1/2"	3	
	NA		SCREW, 1/2"	7	BJ7
58	NA		BRACKET, parcel tray support	1	BN4, BN6, BN7, BT7, BJ7
59 PMZ307	€1.20		SCREW	1	

Battery Access Panels (BN1, BN2, BN6, BN7)

65 806-600	€174.48		BATTERY ACCESS PANEL ASSY	1	
66	NA		HINGE	2	
67	NA		SCREW, hinge to panel	4	
68 GHF206	€1.32		NUT	4	BN1, BN2
69 GHF306	€0.72		WASHER, plain	4	
70 GHF331	€0.84		WASHER, locking	4	
72	NA		STRAP, battery access panel	2	
73 807-055	€177.48		BATTERY ACCESS PANEL ASSY	1	
74	NA		SCREW	4	
75 GHF206	€1.32		NUT	4	BN6, BN7
76	NA		WASHER, plain	4	
77 GHF331	€0.84		WASHER, locking	4	

Heat Shields/Sound Deadening Kits

80 021-682	€132.72		HEAT SHIELD KIT, w/ hardware*	1	BN1, BN2 LHD
021-688	€196.08		HEAT SHIELD KIT, w/ hardware*	1	BN4, BN6, Mkl BN7/BT7
					thru (c)13750
021-683	NA		HEAT SHIELD KIT, w hardware*	1	BN7/BT7 from above,
					BJ7, BJ8
*Hardware included is absolutely correct and authentic.					
81 021-773	€50.04		HEAT SHIELD, exhaust	1	BN1, BN2 (not originally used)
021-776	€61.08		HEAT SHIELD, exhaust	1	BN7/BT7 from (c)13751, BJ7

Ill.	Part Number	Price €ea.	Description	Req.	Details
	021-787	NA	HEAT SHIELD, exhaust	1	BJ8
82	021-788	€33.12	SOUND DEADENING KIT, hood	1	BN7/BT7 from (c)13488,
					BJ7, BJ8 (not UK)
Door Seals					
	85	€18.96	DOOR SEAL, "Furflex", black	A/R	
	552877BLK	€18.96	DOOR SEAL, "Furflex", red	A/R	
	552877RED	€18.96	DOOR SEAL, "Furflex", blue	A/R	BN1, BN2 (sold per yard)
	552877BLU	€18.96	DOOR SEAL, "Furflex", tan	A/R	
	249-790	NA	DOOR SEAL, "Furflex", green	A/R	
	NA		DOOR SEAL, "Furflex", beige	A/R	
	NA		RUBBER DOOR SEAL SET	1	BN4 to C.E.68959
86	682-128	€27.60	DOOR SEAL, red	4	BN4 from C.E.68960 thru
	DER4001	NA	DOOR SEAL, blue	4	BJ8 (sold per meter)
	DEL4001	NA	DOOR SEAL, black	4	
	DEA4001	€27.36	DOOR SEAL, grey	4	
87	249-795	€1.08	CLIP, retaining door seal	A/R	all except BN1, BN2
88	AHB9656	€2.88	CLIP, door seal end	2	
89	NA		SCREW	2	BJ7, BJ8
90	AHB9788	€2.16	END CAP, RH	1	
	AHB9789	€2.16	END CAP, LH	1	

Fasteners and Trim Hardware

95	14A6536	€2.40	TURN BUTTON	A/R	
96	14A6537S	€1.44	EYELET	A/R	
97	TFS106	€4.44	FASTENER (genuine "Tenax" brand)	A/R	
98	TFP1006	€1.56	STUD	A/R	Tenax
98a	GHF206	€1.32	NUT	A/R	
99	GAC5063X	€2.40	KEY, Tenax fastener	1	
100	GHF306	€0.72	WASHER, plain	A/R	
101	GHF331	€0.84	WASHER, locking	A/R	
102	LFS100S	€2.64	FASTENER ASSY	A/R	
103	552670	€2.16	STUD, self-tapping	A/R	Lift-the-Dot
104	226-708	€2.88	STUD AND NUT	A/R	
106	17H9962	€1.92	SNAP, male, with screw	A/R	
107	227-108	€2.16	SNAP ASSY, female	A/R	
108	315-168	€5.64	WASHER SET, nylon (10 pcs.)	A/R	

Note: These are used under items 98, 103 and 104 to protect the car's paint.

110	NA		SCREW, dash top	2	BN4, BN6, BN7, BT7
	NA		SCREW, dash top	1	BJ7
	NA		SCREW, dash top	4	BJ8
111	CD24152	€1.08	CUP WASHER, dash top screw	2	BN4, BN6, BN7, BT7
112	323-698	€9.96	SCREW & WASHER SET	1	BN1 thru BN7/BT7
	323-648	€11.16	SCREW & WASHER SET	1	BJ7
	323-970	€0.84	SCREW & WASHER SET	8	BJ8
113	GHF1230	€1.20	CLIP, door panel	18	BJ8
115	NA		CATCH, magnetic, armrest	1	
116	633-730	€15.36	HINGE, armrest	2	
117	NA		SCREW, hinge	8	BJ8 to (c)26704
118	NA		SCREW, console to tunnel	1	
119	NA		WASHER, CUP	1	
120	GHF421	€0.84	SCREW, armrest to tunnel	4	BJ8 from (c)26705
125	NA		EYE BOLT ASSY, seatbelt attaching	2	
127	228-128	€1.56	VELTEX CARPET RING ASSY with snap	A/R	

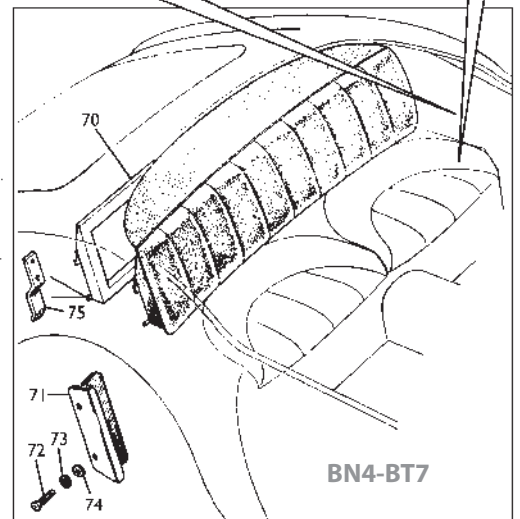
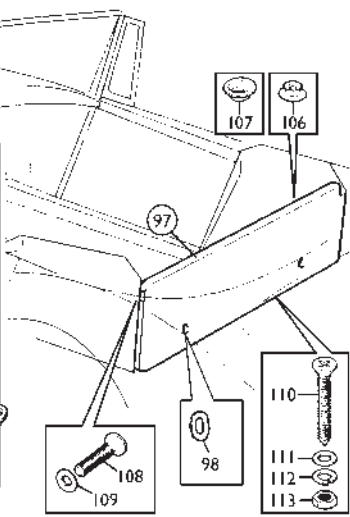
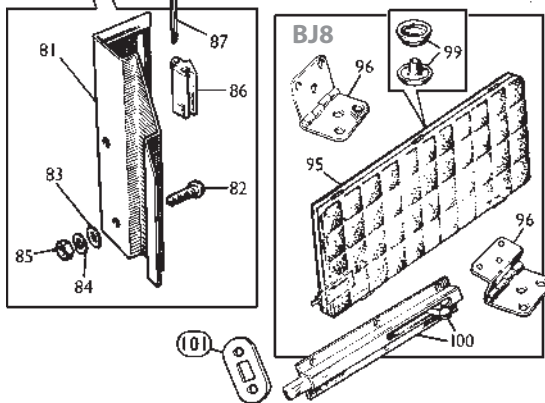
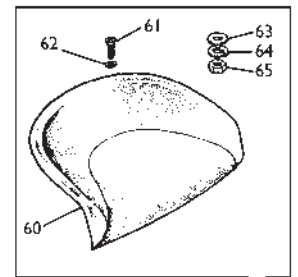
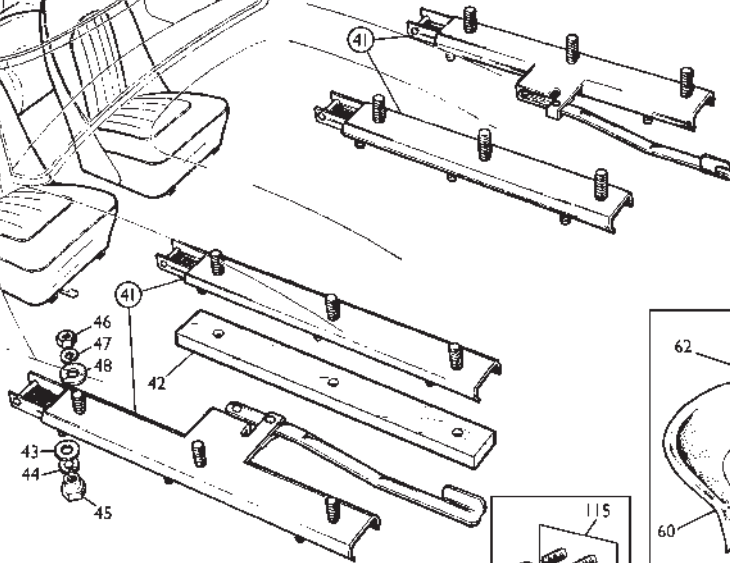
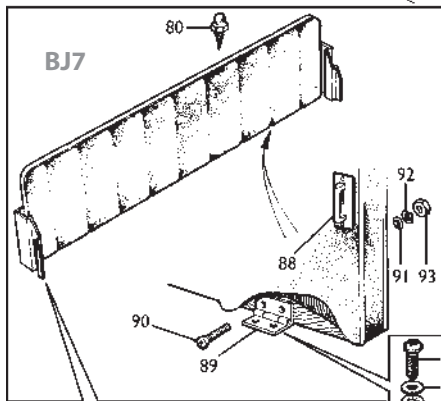
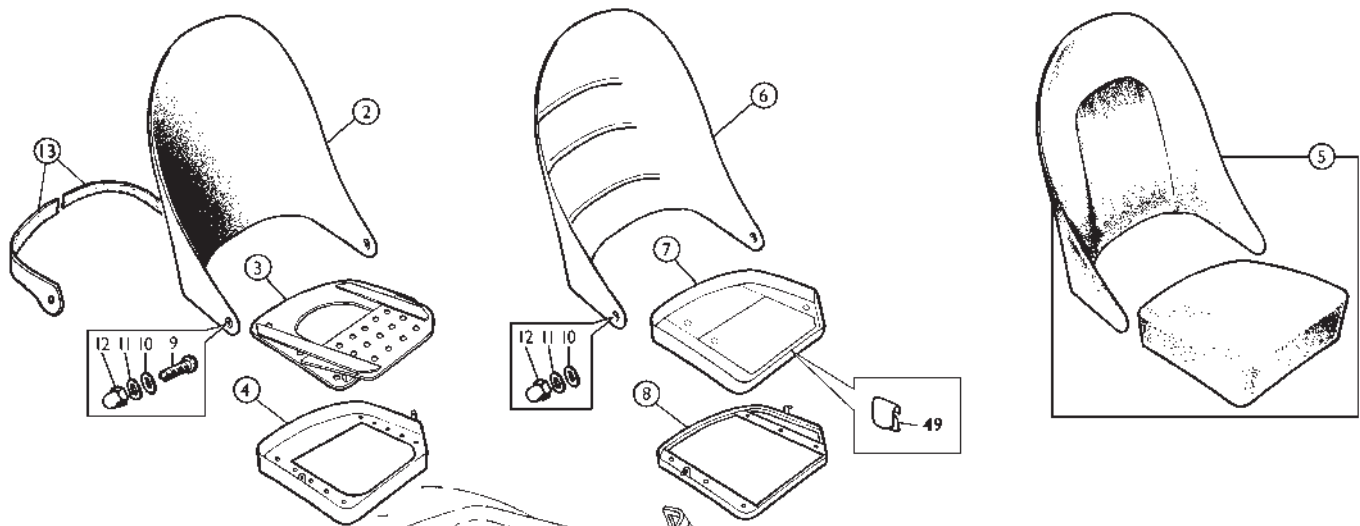

iii. Part Number Price €ea. Description Req. Details

Seat Frames, Foams and Fittings

Front Seats

5	856-198	€108.48	SEAT FOAM SET, RH*	1	} BN1, BN2, BN4 to C.E.68959
	856-218	€110.64	SEAT FOAM SET, LH*	1	
2	856-190	€267.60	SEAT BACK, metal	2	
3	856-210	€58.92	SEAT BASE, wood, RH	1	
	856-220	€58.92	SEAT BASE, wood, LH	1	}
4	856-260	€230.76	FRAME, seat base, RH	1	
	856-250	€230.76	FRAME, seat base, LH	1	

*Note: These are later seat foam sets which may be used for early cars, with some cutting and fitting required.

5	856-198	€108.48	SEAT FOAM SET, RH	1	} BN4 from C.E.68960, BN6, BN7, BT7, BJ7
	856-218	€110.64	SEAT FOAM SET, LH	1	
	643-920	€85.20	SEAT FOAM SET, RH	1	
	643-910	€85.20	SEAT FOAM SET, LH	1	
6	856-200	€351.60	SEAT BACK, metal	2	} BJ8
7	856-240	€192.96	SEAT BASE, metal, RH	1	
	856-230	€192.96	SEAT BASE, metal, LH	1	} BN4 from C.E.68960, BN6, BN7, BT7, BJ7, BJ8
8	856-280	€163.56	FRAME, seat base, RH	1	
	856-270	€163.56	FRAME, seat base, LH	1	} BN1, BN2, BN4 to C.E.68959
9	SH605091	€1.80	BOLT, seat back to frame	4	
10	GHF301	€0.60	WASHER, plain	12	
11	NA	NA	WASHER, chrome	4	
12	14B2685	€3.72	DOME NUT, seat back to frame	4	} BN1-BN4 to C.E.68959
13	856-358	€30.24	TACK STRIP SET (for 2 seats)	1	
	325-765	€1.32	RIVET for tack strips	20	} BN1 to (b)1000 (both seats fixed)
16	NA	NA	TAPPED PLATE, seat mounting	4	
17	NA	NA	BOLT, to floor	8	
18	GHF206	€1.32	NUT	8	
19	NA	NA	WASHER, plain	8	} BN1 to (b)1000 (both seats fixed)
20	GHF331	€0.84	WASHER, locking	8	
21	NA	NA	BOLT, seat to tapped plate	4	} BN1 to (b)1001 on
22	GHF301	€0.60	WASHER, plain	4	
23	GHF332	€0.84	WASHER, locking	4	

Note: BN1 to (b)1000 had both seats mounted directly onto the floor. To adjust these seats, they had to be unbolted and re-mounted. BN1 from (b)1001 thru BN4 C.E.68959 had the driver's seat on adjustable slides, with a wooden spacer between each slide and the floor. The passenger's seat sat on one thick and one thin spacer on each side of the seat, and could be adjusted as the early seats. A factory option did allow for the fitment of seat slides on these seats, with the same mountings and hardware as the driver's seat.

27	BH604101	€0.96	BOLT, packing pieces to floor	6	} fixed pass. seat, BN1, BN2, BN4 to C.E.68959
28	GHF300	€1.08	WASHER, plain, small	10	
29	WM57	€1.20	WASHER, plain, large	6	
30	NA	NA	WASHER, D shaped	6	
31	GHF331	€0.84	WASHER, locking	6	
33	GHF101	€0.72	BOLT, seat to packing piece	4	
34	NA	NA	NUT in bottom packing piece	4	
35	NA	NA	PACKING PIECE, top	2	
36	NA	NA	PACKING PIECE, bottom	2	
40	NA	NA	WASHER PLATES (set of 4)	1	
41	856-380	€79.44	SEAT SLIDE SET, RH	1	} all adjustable seats
	856-390	€79.44	SEAT SLIDE SET, LH	1	
42	856-370	€7.80	PACKING PIECE, seat slide	4	
43	WP9	€2.04	WASHER, plain	12	
44	GHF333	€0.72	WASHER, locking	12	
45	031-329	€3.24	T NUT	12	
46	GHF200	€0.96	NUT	12	
47	GHF331	€0.84	WASHER, locking	12	
48	WM57	€1.20	WASHER, plain	12	
49	GHF1500	€0.84	CLIP, seat covering to seat frame	A/R	

iii. Part Number Price €ea. Description Req. Details

Rear Seats

60	856-160	€141.24	SEAT PAN	2	BN4, BT7, BJ7, BJ8
----	---------	---------	----------	---	--------------------

Note: Seat pan supplied is BJ8 type with welded studs for mounting, and includes washers and nuts. This is a direct replacement for early seat pans which were mounted with sheet metal screws

61	NA	NA	SCREW	8	} BN4, BT7, BJ7 (og. seat pans)
62	CD24152	€1.08	WASHER, cup	8	
63	NA	NA	WASHER, plain	8	} BJ8
64	GHF331	€0.84	WASHER, locking	8	
65	GHF206	€1.32	NUT	8	} BN4 to C.E.68959
70	NA	NA	FRAME ASSEMBLY	1	
	NA	NA	FRAME ASSEMBLY	1	BN4 from C.E.68960, BT7
71	805-045	€48.36	CHANNEL, seat back retaining (pair)	1	} BN4, BT7
72	SE910201	€1.08	SCREW	4	
73	GHF331	€0.84	WASHER, locking	4	} BJ7
74	NA	NA	WASHER, plain	4	
75	805-070	€41.64	PLATE & PEG KIT	1	} BN4, BT7
76	NA	NA	SCREW for plate	4	
80	NA	NA	PEG, hood stowage cover	2	} BJ7
81	805-055	€17.16	BRACKET, seat back, RH	1	
	805-065	€17.16	BRACKET, seat back, LH	1	} BJ7
82	SE604041	€0.84	SCREW	4	
83	GHF300	€1.08	WASHER, plain	4	} BJ7
84	GHF331	€0.84	WASHER, locking	4	
85	GHF200	€0.96	NUT	4	} BJ7
86	2H9215	€2.40	STOP, seat back (also for early BN4)	2	
87	GHF504	€1.08	SPLIT PIN	2	} BJ7
88	2K9579	€7.56	STAPLE, breeching	2	
89	NA	NA	HINGE	2	} BJ7
90	PMZ308	€0.72	SCREW, hinge	8	
91	NA	NA	WASHER, plain	8	} BJ7
92	GHF331	€0.84	WASHER, locking	8	
93	GHF206	€1.32	NUT	8	} BJ7
95	856-460	€399.60	BACK PANEL & PARCEL SHELF ASSY, bare (wood w metal frame & hinges, no covering)	1	
96	856-398	€101.88	HINGE SET (5 hinges)	1	} BJ7
97	NA	NA	PANEL, hood protection, rear part of no.95	1	
98	856-465	€10.20	ESCUTCHEON	2	} BJ7
99	227-108	€2.16	SNAP ASSEMBLY	2	
100	805-040	€76.20	SLIDE BOLT	2	} BJ7
101	021-805	€26.04	ESCUTCHEON ASSY w/back plate & screws	2	
106	610624	€1.20	SNAP STUD	5	} BJ7
107	NA	NA	WASHER, cup	7	
108	SF604121	€1.32	SCREW, panel to wheelarch	4	} BJ7
109	WM57	€1.20	WASHER, plain	4	
110	SF604121	€1.32	SCREW, panel to bulkhead	3	} BJ7
111	WM57	€1.20	WASHER, plain	3	
112	GHF331	€0.84	WASHER, locking	3	} BJ7
113	GHF200	€0.96	NUT	3	
115	805-755	€27.36	SEAT BELT MOUNTING, rear	2	} BT7, BJ7, BJ8 to mid '67
116	14B2685	€3.72	DOME NUT	4	

BN1 - BJ7 Front & Rear Seat Kits

In order to restore the interior of your Austin-Healey to its' original quality, we manufacture early Healey upholstery kits in our own Upholstery Shop with an eye on quality control every step of the way. We use only the finest materials in our kits; our leather is tanned and vat-dyed to the highest standards to ensure durability. Our vinyls have been selected for their color & grain style. Each piece is cut by our skilled craftsmen using patterns painstakingly developed by us. We're so confident of the quality of our upholstery items that we guarantee 100% satisfaction or your money back upon return of the un-installed kit. Order free sample card #878-900 for samples.

All front seat kits include covers for both front seats.

As original from the factory, our leather seat kits have only the seating/wearing surfaces in leather, with the non-wearing surfaces in matching vinyl.

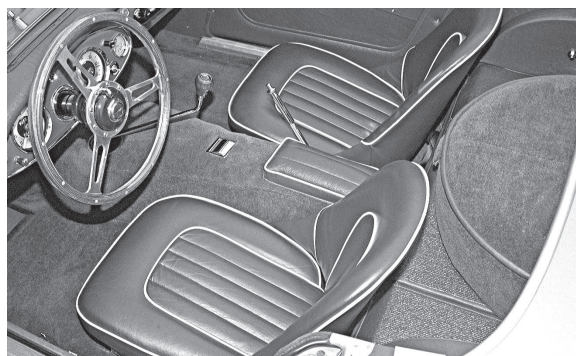

	Main Color - Black	Black	Black	Red	Red	Red	Blue	Blue	Tan	Honey Tan	Price
	Piping Color - Black	White	Red	Red	White	Black	Blue	White	Tan	Honey Tan	
BN1-BN4* Vinyl Seat Kit	246-600	246-610	246-620	246-630	246-640	246-645	246-650	246-655	246-660	246-662	€478.80
BN1-BN4* Leather Seat Kit	246-670	246-680	246-690	246-700	246-710	246-715	246-720	246-725	246-730	246-732	€816.00
BN4** thru BJ7 Vinyl Seat Kit	246-740	246-750	246-760	246-770	246-780	246-785	246-790	246-795	246-800	246-802	€472.80
BN4** thru BJ7 Leather Seat Kit	246-815	246-825	246-835	246-845	246-855	246-856	246-865	246-866	246-875	246-877	€840.00
BN4* Rear Vinyl Seat Kit*	246-880	246-890	246-900	246-910	246-920	246-921	246-930	246-936	246-940	246-942	€226.08
BN4* Rear Leather Seat Kit*	246-950	246-960	246-970	246-980	246-990	246-991	247-000	247-006	247-010	247-012	€378.00
BN4**-BT7 Rear Vinyl Seat Kit	246-885	246-895	246-905	246-915	246-925	246-916	246-935	246-937	246-945	246-947	€228.48
BN4**-BT7 Rear Leather Seat Kit	246-955	246-965	246-975	246-985	246-995	246-996	247-005	246-007	247-015	247-017	€390.00
BJ7 Rear Vinyl Seat Kit	247-020	247-030	247-040	247-050	247-060	247-065	247-070	247-075	247-080	247-082	€230.88
BJ7 Rear Leather Seat Kit	247-090	247-100	247-110	247-120	247-130	247-135	247-140	247-145	247-150	247-152	€472.80
BN1 Vinyl Armrest	247-165	247-175	247-185	247-195	247-205	247-206	247-215	247-217	247-225	247-227	€135.84
BN1 Leather Armrest	247-235	247-245	247-255	247-265	247-275	247-276	247-285	247-287	247-295	247-297	€160.68
BN2 and BN4* Vinyl Armrest	247-160	247-170	247-180	247-190	247-200	247-201	247-210	247-216	247-220	247-222	€128.52
BN2 and BN4* Leather Armrest	247-230	247-240	247-250	247-260	247-270	247-271	247-280	247-286	247-290	247-292	€159.00
BN4** thru BJ7 Vinyl Armrest	247-300	247-310	247-320	247-330	247-340	247-345	247-350	247-355	247-360	247-362	€121.44
BN4** thru BJ7 Leather Armrest	247-370	247-380	247-390	247-400	247-410	247-405	247-420	247-425	247-430	247-432	€101.52

* through C/E68959 (Longbridge-built cars)
** from C/E68960

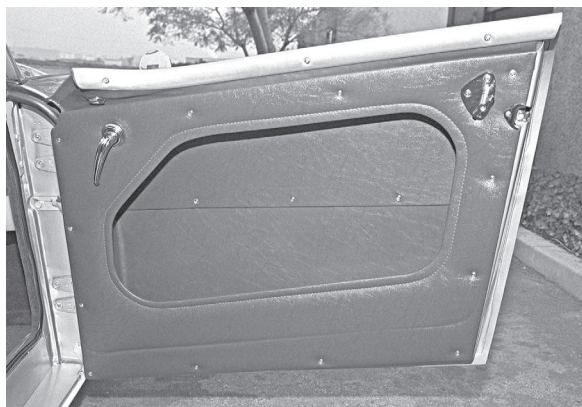

Complete Vinyl Panel Kits

Painstakingly made to match the original designs, these vinyl panel kits give your interior a professional appearance even when installed by the novice. There is no easier way to erase years of wear and tear from your interior than to fit one of our beautiful panel kits! For unmatched durability, we use plywood and waterproof panel board where original. Kits include screw & washer sets. Order free material sample card #878-900.

	Black	Red	Blue	Tan	Honey Tan	Price
100-4 (incl. spare tyre cover)	247-880	247-890	247-900	247-910	247-912	€570.00
100-6 BN4 (Fits all thru BN4 68959.)	247-925	247-935	247-945	247-955	247-957	€742.80
100-6 BN4 & 3000 BT7 (4 seat) (Fits BN4 from 68960 & BT7)	247-965	247-975	247-985	247-995	247-997	€885.60
100-6 BN6 & 3000 BN7 (2 seat)	247-960	247-970	247-980	247-990	247-992	€954.00
3000 BJ7	248-000	248-010	248-020	248-030	248-032	€577.20

323-698	NA	SCREW & WASHER SET, panel kits	BN1-BN7	1
323-648	NA	SCREW & WASHER SET, panel kits	BJ7	1

* Screw & washer sets are included in Panel Kits.

Complete Carpet Sets - LHD

Made in our very own upholstery shop, these carpet kits are carefully patterned and cut for proper fit and easy installation. Each complete kit features the correct rubber heel mat, all necessary snaps and studs and bound edges where original. BN6 & BN7 kits include spare tyre covers. Order free sample card, part number 878-915, for carpet samples.

	Black	Red	Blue	Honey Tan	Price
BN1 with Armacord *	248-720	248-731	248-741	248-736	€520.80
BN1 all carpet **	-	248-730	248-740	248-735	€547.20
BN2 with Armacord *	248-750	248-761	248-771	248-766	€554.40
BN2 all carpet **	-	248-760	248-770	248-765	€554.40
BN4/BT7 Side Shift "Original" †	248-781	248-791	248-801	248-796	€489.60
BN4/BT7 Side Shift "Deluxe" ††	248-780	248-790	248-800	248-795	€552.00
BN6/BN7 Side Shift †	248-810	248-820	248-830	248-825	€579.60
BN7 Centre Shift †	248-840	248-850	248-860	248-855	€627.60
BT7/ BJ7 "Original" †	248-871	248-881	248-891	248-886	€465.60
BT7/ BJ7 "Deluxe" ††	248-870	248-880	248-890	248-885	€579.60

* Carpet and Armacord, as original for BN1 & BN2.

Only black Armacord is available, and may be dyed to match carpet color for original appearance.

** Non-original upgrade for BN1 & BN2, with carpet replacing Armacord.

† As original, with 1-piece transmission cover, bound as original.

†† "Deluxe" (non-original) kits have 2-piece trans. cover, bound on edges, with a flap for trans. dipstick access.

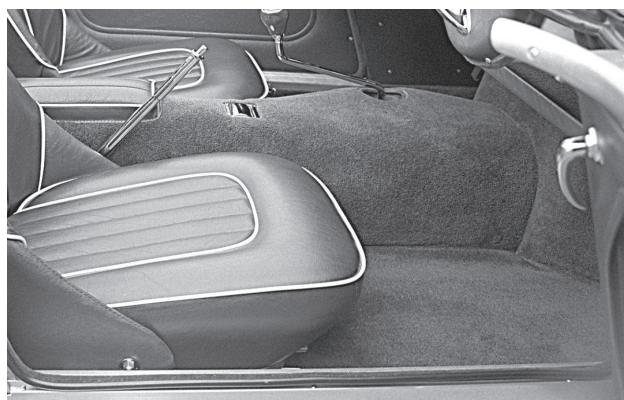

"AUSTIN" RUBBER HEEL MAT (included in carpet kits)

680-950 €19.32

Front & Rear Seat Upholstery Kits

Our seat kits are manufactured in England from top-grade materials, including correct chrome herringbone piping and all the important details like the small embossed squares on the standard front vinyl seat cushions. Our vinyl rear seat kits incorporate the correct heat-welded large square pattern just like the originals. As did the factory, we give you the option to upgrade to luxurious (and wonderfully aromatic) leather as well. On these kits, the piping matches the color of the seat. Whichever your choice, be assured that either will renew the interior of your Austin-Healey to original standards. You don't need to be an upholsterer to install a Moss kit either! The seat covers easily replace the old ones with no sewing needed. One easy weekend is all the time you will probably need to complete the task. (If you are at all timid about attempting such a project, order our instructional video part # 211-026, and see how the pros do it step-by-step.)

Order free sample card #878-940 for vinyl and leather samples.

All front seat kits include covers for both front seats. As original from the factory, our leather seat kits have only the seating/wearing surfaces in leather, with the non-wearing surfaces in matching vinyl.

	Black	Red	A-H Blue	Dark Blue	Light Tan†	Price
Vinyl Front Seat Kit	247-450	247-470	247-491	247-490	247-500	€634.80
Leather Front Seat Kit	247-510	247-530	247-551	247-550	247-570	€1,027.20
Vinyl Rear Seat Kit	247-590	247-610	247-631	247-630	247-640	€728.40
Leather Rear Seat Kit	247-650	247-670	247-691	247-690	247-710	€741.60
Vinyl Hinged Armrest*	247-720	247-730	247-741	247-740	247-750	€117.24
Leather Hinged Armrest*	247-760	247-770	247-781	247-780	247-790	€146.52
Vinyl Fixed Armrest*	247-800	247-810	247-821	247-820	247-830	€106.20
Leather Fixed Armrest*	247-840	247-850	247-861	247-860	247-870	€135.36

*Hinged and fixed armrests are not interchangeable. Hinged armrests with a cubby box under them were used to car number 26704. Fixed armrests with no cubby box were used from car no. 26705.

† Light tan as supplied is the correct BJ8 tan.

Complete Vinyl Panel Kits

Painstakingly made to match the original designs, these vinyl panel kits give your interior a professional appearance even when installed by the novice. There is no easier way to erase years of wear and tear from your interior than to fit one of our beautiful panel kits! For unmatched durability, we use plywood and waterproof panel board as original. Reuse your old door panel clips or purchase new ones listed below.

	Black	Red	A-H Blue	Dark Blue	Light Tan†	Price
3000 BJ8 thru (c)26704	248-040	248-050	248-061	248-060	248-070	€714.00
3000 BJ8 from (c)26705	248-080	248-090	248-701	248-700	248-710	€714.00

† Light tan as supplied is the correct BJ8 tan.

DOOR PANEL CLIPS (18 required per car) GHF1230 €1.20

Complete Carpet Sets - LHD (cut pile carpet)

Made in our very own upholstery shop (except for Light Tan, which is English), these carpet kits are carefully patterned and cut for proper fit and easy installation. Each complete kit features the correct rubber heelmat, all necessary snaps and studs. "Orig. style" kits have a one-piece transmission cover, and are bound only around the shifter hole. "Deluxe" kits have a two-piece transmission cover with a dipstick access flap, and are bound on exposed edges. For free samples of our carpet material, order sample card #878-915.

		Black	Red	Blue	Honey Tan	Price
3000 BJ8 thru (c)26704	Orig. style	248-871	248-881	248-891	248-886	€465.60
	"Deluxe"	248-870	248-880	248-890	248-885	€579.60
3000 BJ8 from (c)26705	Orig. style	248-901	248-911	248-921	248-916	€465.60
	"Deluxe"	248-900	248-910	248-920	248-915	€595.20

Door Hood Rails, BJ8

Just like the originals, our complete assembled rails include the sheet metal base with a molded foam core covered in durable black vinyl with a grain that matches our interior kits.

858-158 €118.68

Be sure to see our complete listing of interior hardware, seat foam, seat frames and related items on pages 140-141.

BJ7 & BJ8 Upholstery Installation DVD

Follow a 4 hour installation of a trunk lining kit, carpet and panel kits, seat rebuilding and recovering, and a convertible hood. This DVD takes you through each process in step-by-step detail. You will learn the tricks the pros use.

211-026 €100.68



Convertible Hoods

We offer a choice of two premium vinyl materials, British "Everflex", which is as close as possible to the original, and a domestic crush-grain vinyl. We also carry Robbins Stayfast Cloth hoods. Stayfast is manufactured for Robbins using a 100% acrylic surface cloth laminated with a superior rubber formulation to a pre-shrunk cotton backing cloth. Stayfast is soft and supple to make installation of hoods easier, and with tightly controlled strength characteristics to ensure that hoods do not sag, billow or lose their shape over time.

All the necessary fasteners are included in our kits but they are not installed, as there may be variations in the locations of existing mounting hardware.

Although good results may be achieved by non-professionals, best results are achieved by a professional with experience with Healey hood cover installation. For this reason our hoods do not come with installation instructions.

The BJ7-BJ8 hood is a tricky installation, and we recommend that it not be attempted without first viewing and understanding the information in the #211-026 Soft Trim Installation Video.



100-4 BN1, BN2	Black	Price	Blue	Price	Red	Price	Tan	Price	White	Price
Robbins Stayfast canvas	641-001	€1,087.20	641-002	€1,087.20	641-004	€1,087.20	641-003	€1,087.20	-	
Robbins Everflex Vinyl	300-370	€1,092.00	300-371	€936.00	300-374	€936.00	300-372	€1,092.00	300-373	€1,092.00
Robbins Crush Grain Vinyl	300-330	€823.20	-		-		300-332	€823.20	300-333	€823.20

100-6 BN4 through CE 68959	Black	Price	Blue	Price	Red	Price	Tan	Price	White	Price
Robbins Stayfast canvas	300-400	€1,202.40	300-401	€1,202.40	300-404	€1,202.40	300-402	€1,202.40	-	
Robbins Everflex Vinyl	300-375	€982.80	300-376	€889.20	300-378	€889.20	300-377	€982.80	300-379	€982.80
Robbins Crush Grain Vinyl	300-335	€790.80	-		-		300-337	€790.80	300-338	€790.80

100-6 BN4 from CE 68960; 3000 BT7 through CE 1528

	Black	Price	Blue	Price	Red	Price	Tan	Price	White	Price
Robbins Stayfast canvas	641-021	€969.60	641-022	€969.60	641-024	€969.60	641-023	€969.60	-	
Robbins Everflex Vinyl	021-527	€880.80	641-020	€538.80	300-382	€700.80	300-383	€700.80	300-384	€700.80
Robbins Crush Grain Vinyl	300-340	€799.20	-		-		300-342	€799.20	300-343	€799.20

3000 BT7 from C.1529 on

	Black	Price	Blue	Price	Red	Price	Tan	Price	White	Price
Robbins Stayfast canvas	641-031	€969.60	641-032	€969.60	641-034	€969.60	641-033	€969.60	-	
Robbins Everflex Vinyl	300-385	€974.40	300-386	€877.20	300-388	€877.20	300-387	€974.40	300-389	€974.40
Robbins Crush Grain Vinyl	300-345	€778.80	-		-		300-347	€778.80	300-348	€778.80

100-6 BN6; 3000 BN7

	Black	Price	Blue	Price	Red	Price	Tan	Price	White	Price
Robbins Stayfast canvas	641-011	€876.00	641-012	€876.00	641-014	€876.00	641-013	€876.00	-	
Robbins Everflex Vinyl	021-529	€538.80	641-010	€579.60	300-405	€538.80	300-349	€538.80	300-406	€538.80
Robbins Crush Grain Vinyl	300-350	€705.60	-		-		300-352	€705.60	300-353	€705.60

3000 BJ7 through (B) 59371 (to approx. Apr. '63) (Fold down rear window. Rear window clips not included - reuse originals)

	Black	Price	Blue	Price	Red	Price	Tan	Price	White	Price
Robbins Stayfast canvas	641-061	€1,060.80	641-062	€1,060.80	641-064	€1,060.80	641-063	€1,060.80	-	
Robbins Everflex Vinyl	021-531	€879.60	300-391	€879.60	300-407	€879.60	300-392	€879.60	300-408	€879.60
Robbins Crush Grain Vinyl	300-355	€507.60	-		-		300-357	€507.60	300-358	€507.60

3000 BJ7 from (B) 59372 (approx. Apr 63); 3000 BJ8

	Black	Price	Blue	Price	Red	Price	Tan	Price	White	Price
Robbins Stayfast canvas	641-071	€1,060.80	641-072	€1,060.80	641-074	€1,060.80	641-073	€1,060.80	-	
Robbins Everflex Vinyl	300-395	€904.80	300-396	€784.80	300-409	€784.80	300-397	€904.80	300-410	€904.80
Robbins Crush Grain Vinyl	300-360	€620.40	-		-		300-362	€620.40	300-363	€620.40



Convertible Hoods

Robbins' Hoods Features:

Computerized Cutting - Gerber Cutter cutting technology to ensure all pieces are the correct shape and size.

Factory Designs Improved - Robbins improves upon factory designs by adding reinforcements, better heatsealing processes, and other proprietary manufacturing techniques to produce the highest quality hoods available.

Heatsealed Reinforcements - All seams are double stitched and heatsealed for extra strength and to prevent side to side shrinking. Seams will not bubble or fail over time as do glued reinforcements.

Innovation - Robbins has been granted numerous patents for their innovative designs and techniques. They are the industry leader.

Since 1943 - Their experience is unmatched in the industry. All of their products are still made in the factory in Ventura, California.

100-4 BN1, BN2

Hood frame is mounted to the inside of the cockpit using 3 large Phillips head screws. Chrome latches securing hood to w/s frame are on the outside of the w/s frame uprights. Must reuse the flat steel bar 34.5" long, found inside the rear edge of the hood. This hooks under the two rear retainers to hold the rear of the hood down. Side and rear of hood secured to car by tall turn-button fasteners at the hood of the B pillar. Two Tenax fasteners on each side, one on the wing, one on the rear shroud.

100-6 BN4 through CE 68959

Early BN4s were the first 4 seater Big Healey, and they were fitted with a complicated sliding & folding hood frame permanently attached to the body. All Longbridge BN4s built Sept 56-Aug 57 (6,045 cars) and the BN4s built at Abingdon from Nov 57-Apr 58 (4,241 cars) would have been fitted with the sliding/folding hood. Hood is secured with 12 Tenax fasteners and 2 turn buttons. The single plastic window is sewn in.

100-6 BN4 from CE 68960; 3000 BT7 through CE 1528

Four seaters. Removable hood frame, fits into sockets behind the door opening. Legs of hood frame bend outward sharply 9" from the tips. Same sockets were used to mount the hardtop. BN4 & BT7 hoods had 2 grey webbing straps, secured under the wooden front hood bow, and screwed to the rear bow. Hood is secured across the back with 12 Tenax fasteners and 2 turn buttons.

3000 BT7 from C.1529 on

Four seater. At chassis BT7 1529, (date unknown) legs of hood frame were modified. The bend disappeared, and the socket for the hood frame was mounted farther back on the hood of the rear inner fender well. BT7 hoods had 2 grey webbing straps, sewn to the hood and secured under the wooden front hood bow. They were not screwed to the hood frame.

100-6 BN6; 3000 BN7

Two seater. Removable hood frame attached to front header bow, collapsible cant rails over the doors. Ends of the legs had adjusting screws to adjust the tension. Bottom 2.5" of legs had cream colored plastic sleeves to protect the aluminium trim pieces around the sockets. Secured with 4 Tenax Fasteners.

3000 BJ7 through (B) 59371 (to approx. Apr. '63)

Four seater, roll up windows. Hood frame bolts to a flat-topped pillar near the B-post. Hood permanently attached to the car. Cant rails over doors are vinyl covered wood with aluminium pieces to hold the seal for the windows. Rear window secured with metal clips to a metal plate so the window could be lowered with the hood up for better ventilation. The later hood w/zippered window will fit if the metal strip for the clips is removed.

3000 BJ7 from (B) 59372 (approx. Apr 63); 3000 BJ8

Same as BJ7 except for rear window. Rear window has a zipper so the window can be lowered with the hood up for better ventilation. (These hoods can be fitted to any BJ7, so the early BJ7 hood with the clip-in rear window can be replaced.)

Top Frames (See color section at the front of this catalogue for illustrations)

ill	Part Number	Price €ea.	Description	Req.	Details
	453-670	€375.60	HOOD FRAME ASSEMBLY	1	BN1, BN2
	453-675	€375.60	HOOD FRAME ASSEMBLY	1	100-6 BN4 thru C.E.68959
	453-666	NA	HOOD FRAME ASSEMBLY	1	100-6 BN4 from C.E.68960, 3000 BT7 thru C.E.1528
	453-667	€470.40	HOOD FRAME ASSEMBLY	1	3000 BT7 from C.E.1529
	SC1619	€399.60	HOOD FRAME ASSEMBLY	1	100-6 BN6, 3000 BN7
	453-655	NA	HOOD FRAME ASSEMBLY	1	3000 BJ7, BJ8



100-4 Side Screen Set

Part Number	Price €ea.	Description	Req.	Details
-------------	------------	-------------	------	---------

These UK-made reproductions are excellent quality duplicates of the most popular later style 100 side screen. While at least two other styles were fitted to the early 100, this set fits all 100s.

259-108	€904.80	BLACK		
259-138	€904.80	RED		
259-118	€904.80	BLUE		

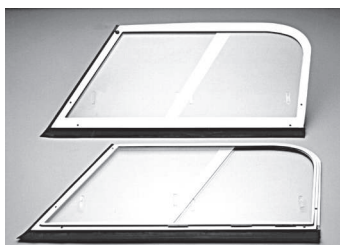

100-6 & 3000 Original Style Side Screen Set

Our 6-cylinder roadster side screens are very similar to the factory originals. Frames are polished anodized aluminium and feature extruded rubber seals. All mounting brackets are included.

24B635/6	€462.00	BN4 thru C.E.47703		
259-212	€627.60	BN4 from 47703 thru BT7		



(100-6 shown)



Side Screen Storage Bags

Part Number	Price €ea.	Description	Req.	Details
-------------	------------	-------------	------	---------

Accurate reproduction of the original stowage bag supplied when the cars were new. A number of original patterns were used during 100-4 production, and our reproduction is the most popular style.

248-930	€83.76	100-4 Stowage Bag		
AHB5483	€76.20	100-6 & 3000 Stowage Bag		



Boot Liner Kits

Complete your restoration with one of our "tailored to your car" boot liner sets. Supplied in black "Armocord" only.

249-912	€334.80	BN1 & BN2 (concours grade)*		
249-930	€256.80	BN4 & BT7		
249-920	€457.20	BN6 & BN7		
249-930	€256.80	BJ7 & BJ8		

*see page 119 for details

3000 BJ7 and BJ8 Convertible Hood Storage Covers

As with our tonneau covers, our hood stowage covers are manufactured for us in England to the exact original specifications in the British "Everflex" material in the correct colors. We have the BJ8 hood boots in Sun-Fast acrylic canvas, as well.

	Black	Price	White	Price	Blue	Price	Red	Price
3000 BJ7 Hood Storage Cover, vinyl	AHB9804	NA	NA		643-110	€343.20	643-105	€343.20
3000 BJ8 Hood Storage Cover, vinyl	AHB6838	NA	NA		643-130	€343.20	NA	
	Black	Price	Blue	Price	Tan	Price		
3000 BJ8 Hood Storage Cover, Sun-Fast canvas	643-091	€1,080.00	643-092	€1,080.00	643-093	€1,080.00		

Tonneau Covers

Our tonneau covers are manufactured for us to the exact original specifications and patterns from British Everflex material in the correct colors. We also offer these made from "Stayfast" heavy acrylic canvas. "Stayfast" is engineered to be soft, supple and with tightly controlled stretch characteristics to insure that covers do not sag or otherwise lose their shape. All necessary fasteners are included with each tonneau cover kit, but not installed so you can get a perfect fit.

VINYL	Black	Price	White	Price	Blue	Price	Red	Price
100-4 BN1 thru body no.4605	643-004	€294.00	643-007	€294.00	643-009	€294.00	643-006	€261.60
100-4 BN1 & BN2 from BN1 body no. 4606	021-535	NA	NA		643-010	€294.00	643-005	€294.00
100-6 BN6 & 3000 BN7 (Fits all 2 seaters.)	021-536	€598.80	NA		643-030	€298.80	NA	
100-6 BN4 & 3000 BT7 (Fits all 4 seaters.)	021-537	NA	643-040	€400.80	643-050	NA	643-045	€439.20
3000 BJ7 and BJ8	AHB9821	€442.80	643-060	NA	643-070	NA	643-065	€442.80

Be sure to turn to pages 139-143 for additional tonneau cover components (bows & stiffener sets)

STAYFAST	Black	Price	Blue	Price	Tan	Price		
100-4 BN1 & BN2 from BN1 body no. 4606 ("long")	643-001	€963.60	643-002	€963.60	643-003	€963.60		
100-6 BN6 & 3000 BN7 (Fits all 2 seaters.)	643-021	€990.00	643-022	€974.40	643-023	€1,032.80		
100-6 BN4 & 3000 BT7 (Fits all 4 seaters.)	643-041	€849.60	643-042	€830.40	643-043	€906.00		
3000 BJ7 and BJ8	643-061	€811.20	643-062	€849.60	643-063	€948.00		

Be sure to turn to pages 133-137 for additional tonneau cover components (bows & stiffener sets)

Our thanks to John Twist of Grand Rapids, Michigan for providing the following words of wisdom regarding electrical trouble-shooting, and for making sense out of standard Lucas wiring harness color coding as applicable to most British post-World War II vehicles.

Sorting out electrical problems requires a step-by-step, methodical approach. It is necessary to identify the problem, examine the wiring diagram, then trace the circuit, connection to connection (usually from the hot side), until the problem is found.

A quarter of all electrical problems arise from faulty battery connections; another quarter from a dirty fuse box.

As a rule, wires do not fail. The bullet connectors may corrode at the ends of the wires (rarely), or the connections may be loose (common!), but the wires are usually OK. Another rule: Wires begin and end outside the loom. There is no reason to cut through the PVC tape.

BLACK (B) Always EARTH (ground), unfused

Black (B):	Various locations
Black/green (BG):	URP switch to cooling fans
Black/white (BW):	Brake warning light

BROWN (N) Always HOT, unfused

Brown (N):	Various locations
Brown/light green (NLG):	Windscreen motor switch
Brown/yellow (NY):	Indicator light to alternator
Brown/purple (NP):	Unused

WHITE (W) HOT with ignition ON, unfused

White (W):	Key to ignition relay, cut-off switch, fuel pump, ignition ballast resistor, fuse box, various locations
White/black (WB):	distributor to coil, coil to tachometer
White/blue (WU):	Stepped down voltage for distributor amplifier
White/brown (WN):	Ignition switch relay to fuse box, starter solenoid to starter relay, oil pressure sender unit to gauge
White/green (WG):	Key switch to radio, HOT unfused at first key position; wipers and heater (earlier)
White/light green (WLG):	Solenoid to coil, ignition ballast resistor to coil
White/red (WR):	Key switch to starter relay, starter relay to brake warning diode

PURPLE (P) Always HOT, fused

Purple (P):	Fuse box to horn, various locations
Purple/black (PB):	Horn to horn switch
Purple/green (PG):	Key buzzer to time delay buzzer
Purple/pink (PK):	Key switch to key buzzer
Purple/white (PW):	courtesy lamp/boot lamp to earthing switches

It may be easier to visualize the wiring as plumbing: Wires as pipes; switches as valves; the battery as pressure; and all "juice" must return to the battery.

Light bulbs work or not. A dimly glowing bulb indicates a faulty earth (ground).

Carb. cleaner removes paint or undercoating from wires to expose the true color code.

If the trunk earth (ground) connection is loose or unattached (license holder bolts), the fuel pump, side markers, courtesy light, reverse lights, license lights, or tail-lights malfunction.

If the hazard switch is not snapped off with vigor, the turn signals may not operate.

Tools: A 12-volt test light and wiring diagram are necessities before beginning.

Warning: Approaching an electrical malfunction without a test light, or helter skelter, is a certain route to madness.

GREEN (G) HOT with ignition ON, fused

Green (G):	From fuse box to various locations
Green/black (GB):	Fuel tank unit to gauge
Green/blue (GU):	Temp. sender unit to gauge
Green/brown (GN):	Reverse lamp switch to reverse lights; heater fan to switch
Green/orange (GO):	Brake pressure switch, handbrake switch, brake warning diode, brake warning light
Green/pink (GK):	Service interval counter (EGR light)
Green/red (GR):	Left turn signals to switch
Green/white (GW):	Right turn signals to switch
Green/yellow (GY):	Heater to fan switch

RED (R) Parking lights, fused or unfused

Red (R):	Fuse box to side markers, parking lights, switch to lights,
Red/green (RG):	Light switch to fuse box, panel rheostat
Red/light green (RLG):	Wiper motor to switch
Red/white (RW):	Panel rheostat to panel lights
Red/Yellow (RY):	Fog/Driving lights

BLUE (U) Headlamps, unfused

Blue (U):	Light switch to dimmer switch
Blue/light green (ULG):	Wiper motor to switch
Blue/red (UR):	Dimmer switch to low beam
Blue/white (UW):	Dimmer switch to high beam, high beam indicator

LIGHT GREEN (LG) Various applications

Light Green/black (LGB):	Washer pump to switch
Light Green/brown (LGN):	Flasher to turn signal switch, flasher hazard switch
Light Green/green (LGG):	Voltage stabilizer to fuel/temp. gauges
Light Green/purple (LGP):	Hazard switch to hazard warning lamp

SLATE (S) HOT with ignition OFF, fused and unfused

Slate (S):	Key to in-line fuse
Slate/purple (SP):	Fuse to anti-run on valve
Slate/yellow (SY):	Anti-run on valve to oil pressure switch

YELLOW (Y) HOT in 3rd/4th, ignition ON, fused

Yellow (Y):	Overdrive switches
Yellow/brown (YN):	Driver's seat belt to time delay buzzer
Yellow/purple (YP):	Time delay buzzer to seat belt warning light; overdrive circuit
Yellow/red (YR):	Overdrive circuit

Lucas Archives - Starting System

RECOMMENDED TEST EQUIPMENT:

D.C. Moving Coil Voltmeter Scale 0-20V

Hydrometer

Note:

1. Test figures quoted are typical only
2. During testing, the engine should be cranked without starting:
Gas - Disconnect coil to distributor LT lead
Diesel - Operate engine stop control

TEST:	RESULT
-------	--------

1 HYDROMETER READING

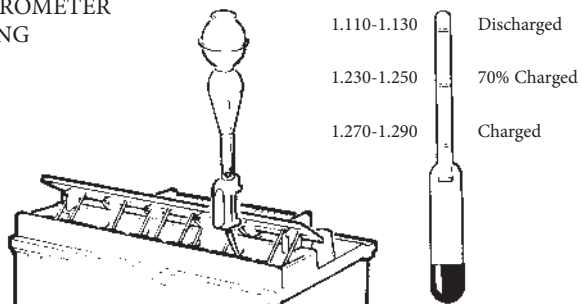

Below 1.230
Recharge and then test
—————> Test 2
1.230-1.290
—————> Test 2

2 CONNECTIONS

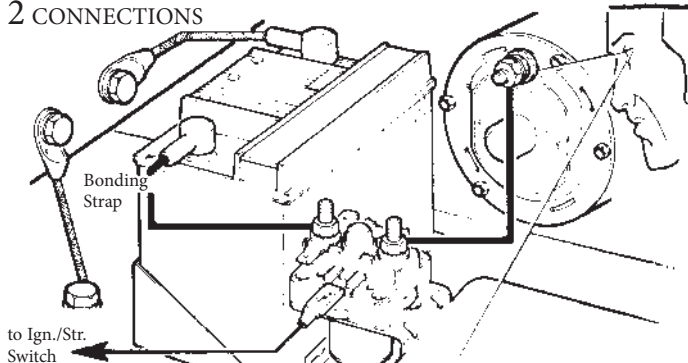

Clean and tight
—————> Test 3
Loose and/or dirty
Rectify
—————> Test 3

3 BATTERY VOLTAGE, ON LOAD

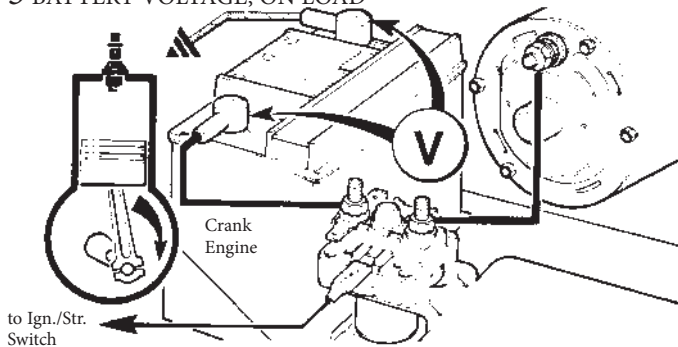

If starter does not motor, check solenoid operation, cables, earth connections. Rectify. Should be approx.
Inertia 10.5v
Pre-Engaged 10.0v
—————> Test 4
Below expected voltage, check battery charge and if low, re-test with good battery
—————> Test 4

4 VOLTAGE AT SOLENOID OPERATING TERMINAL

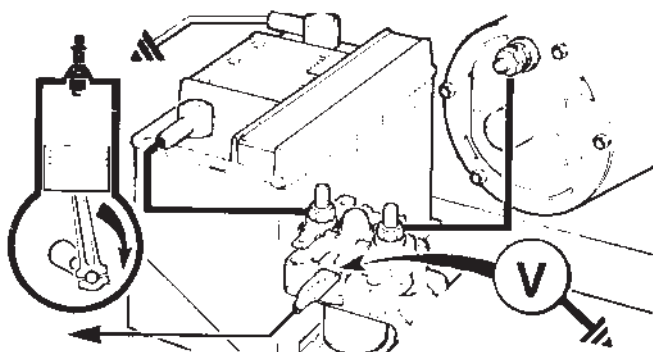

Should be:
Similar voltage to previous test
—————> Test 5
If voltage is lower than in previous test, check ignition/starter switch, all cables and connections, etc. Rectify.
—————> Test 5
See also note below

Lucas Archives - Starting System

Should be:
Within 0.5V of voltage
in test 3

→ Circuit
Satisfactory

Voltage more than 0.5V
below reading in test 3

→ Test 6

5 VOLTAGE AT STARTER, ON LOAD

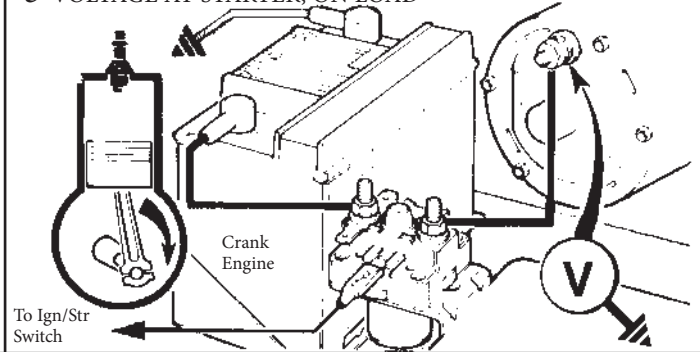

Should be:
Approx. zero voltage

→ Test 8

If above 0.5V

→ Test 7

6 VOLTAGE DROP, INSULATED LINE

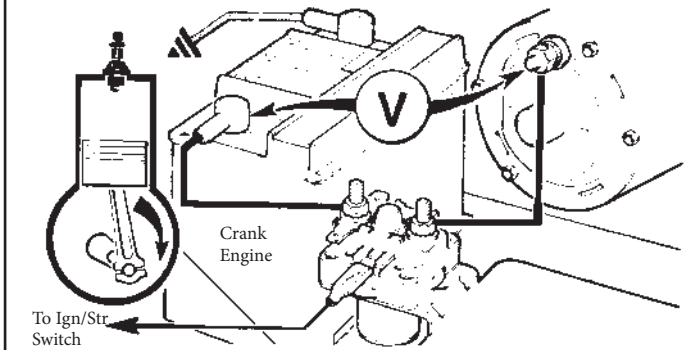

Should be:
Approx. zero voltage.
If shown, solenoid is
satisfactory and a fault
exists elsewhere in the
circuit. Check all insu-
lated line cables and
connections. Rectify.
Re-check as test 6

→ Test 8

If above 0.25 V, replace
solenoid

→ Test 8

7 VOLTAGE DROP, SOLENOID CONTACTS

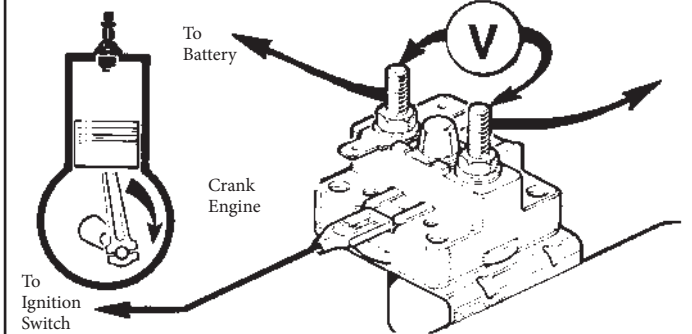

Should be:
Approx. zero voltage.

If above 0.25V, check
all earth connections
including chassis/
engine bonding strap.

8 VOLTAGE DROP, EARTH LINE

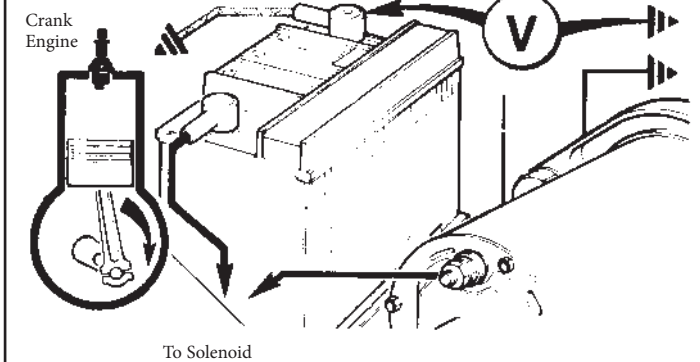

General Hardware & Fixings

Following is a listing of the common fasteners used on Austin-Healey cars. These fasteners are for general use and are not intended to replace those listed for specific applications elsewhere in this catalogue. To aid identification by terminology, a screw is threaded for its full length. A bolt is only part threaded with a plain unthreaded shank area between the head and the thread. The part number two letter prefix of SH means that the item is a Screw with a Hexagon head. The prefix BH means a Bolt with a Hexagon head. The first number defines the thread type, UNF = 6, UNC = 5. The second and third numbers give the thread diameter in increments of 1/16", e.g. 04 = 1/4", 05 = 5/16", 10 = 5/8". The fourth and fifth digits show the length in increments of 1/8", e.g. 04 = 1/2", 16 = 2", 23 = 2 7/8". The last digit defines finish, 1 = zinc plated. This coding system is only applicable to bolts and screws; nuts & washers are coded by a similar system that follows some of the above principles.

Bolts and Set Screws

3/16" UNF

Hexagon Headed 3/8" A.F. Spanner Size

Bolt	Length	Set Screw
	3/8"	HU503
	1/2"	HU504
	5/8"	HU505
	3/4"	HU506
	7/8"	HU507
	1"	HU508

1/4" UNF

Hexagon Headed 7/16" A.F. Spanner Size

Bolt	Length	Set Screw
	3/8"	SH604031
	1/2"	SH604041
	5/8"	SH604051
	3/4"	SH604061
	7/8"	SH604071
BH604081	1"	SH604081
BH604091	1 1/8"	SH604091
BH604101	1 1/4"	SH604101
BH604111	1 3/8"	SH604111
BH604121	1 1/2"	SH604121
BH604141	1 3/4"	SH604141
BH604161	2"	SH604161
BH604181	2 1/4"	
BH604201	2 1/2"	
BH604241	3"	

5/16" UNF

Hexagon Headed 1/2" A.F. Spanner Size

Bolt	Length	Set Screw
	3/8"	SH605031
	1/2"	SH605041
	5/8"	SH605051
	3/4"	SH605061
	7/8"	SH605071
	1"	SH605081
BH605091	1 1/8"	SH605091
BH605101	1 1/4"	SH605101
BH605111	1 3/8"	SH605111
BH605121	1 1/2"	SH605121
BH605141	1 3/4"	SH605141
BH605151	1 7/8"	SH605151
BH605161	2"	SH605161
BH605181	2 1/4"	SH605181
BH605201	2 1/2"	SH605201
BH605221	2 3/4"	SH605221
BH605241	3"	SH605241

3/8" UNF

Hexagon Headed 9/16" A.F. Spanner Size

Bolt	Length	Set Screw
	3/8"	SH606031
	1/2"	SH606041
	5/8"	SH606051
	3/4"	SH606061
	7/8"	SH606071
BH606081	1"	SH606081
BH606091	1 1/8"	SH606091

3/8" UNF (Continued)

BH606101	1 1/4"	SH606101
BH606111	1 3/8"	SH606111
BH606121	1 1/2"	SH606121
BH606141	1 3/4"	SH606141
BH606161	2"	SH606161
BH606181	2 1/4"	SH606181
BH606201	2 1/2"	SH606201
BH606221	2 3/4"	
BH606241	3"	
BH606281	3 1/2"	
BH606321	4"	

7/16" UNF

Hexagon Headed 5/8" A.F. Spanner Size

Bolt	Length	Set Screw
	5/8"	SH607051
	3/4"	SH607061
	7/8"	SH607071
	1"	SH607081
	1 1/8"	SH607091
	1 1/4"	SH607101
	1 3/8"	SH607111
BH607121	1 1/2"	SH607121
BH607141	1 3/4"	SH607141
BH607161	2"	SH607161
BH607181	2 1/4"	SH607181
BH607201	2 1/2"	
BH607241	3"	

1/2" UNF

Hexagon Headed 3/4" A.F. Spanner Size

Bolt	Length	Set Screw
	1/2"	SH608041
	5/8"	SH608051
	1"	SH608081
	1 1/2"	SH608121
BH608141	1 3/4"	SH608141
BH608161	2"	
BH608181	2 1/4"	
BH608201	2 1/2"	SH608201
BH608241	3"	

1/4" UNC

Hexagon Headed 7/16" A.F. Spanner Size

Bolt	Length	Set Screw
	3/8"	SH504031
	1/2"	SH504041
	5/8"	SH504051
	3/4"	SH504061
	7/8"	SH504071
	1"	SH504081
BH504091	1 1/8"	SH504091
	1 1/4"	SH504101
BH504111	1 3/8"	SH504111
BH504121	1 1/2"	SH504121
BH504141	1 3/4"	SH504141
BH504161	2"	
BH504181	2 1/4"	SH504181
BH504201	2 1/2"	

5/16" UNC

Hexagon Headed 1/2" A.F. Spanner Size

Bolt	Length	Set Screw
	3/8"	SH505031
	1/2"	SH505041
	5/8"	SH505051
	3/4"	SH505061
	7/8"	SH505071
	1"	SH505081
	1 1/8"	SH505091
	1 1/4"	SH505101
BH505101	1 1/4"	SH505101
BH505111	1 3/8"	SH505111
BH505121	1 1/2"	SH505121
BH505141	1 3/4"	SH505141
BH505161	2"	
BH505181	2 1/4"	
BH505201	2 1/2"	SH505201
BH505241	3"	

3/8" UNC

Hexagon Headed 9/16" A.F. Spanner Size

Bolt	Length	Set Screw
N/A	1/2"	SH506041
N/A	3/4"	SH506061

3/8" UNC (Continued)

	7/8"	SH506071
BH506081	1"	SH506081
	1 1/8"	SH506091
	1 1/4"	SH506101
BH506111	1 3/8"	SH506111
BH506121	1 1/2"	SH506121
BH506141	1 3/4"	
BH506161	2"	SH506161
BH506181	2 1/4"	
BH506201	2 1/2"	
BH506241	3"	SH506241

Screws

Self Tapping Screws

Pan Headed	Size	Length	Countersunk Headed
AB604021	No.4	1/4"	AC604021
AB606021	No.6	1/4"	
AB606031	No.6	3/8"	
AB606041	No.6	1/2"	GHF400
AB606061	No.6	3/4"	AC606061
AB606081	No.6	1"	AC606081
AB608041	No.8	1/2"	AC608041
AB608061	No.8	3/4"	AC608061
AB608081	No.8	1"	
GHF425	No.10	1/2"	AC610041
AB610061	No.10	3/4"	AC610061
AB610081	No.10	1"	AC610081
AB612041	No.12	1/2"	AC612041
AB612061	No.12	3/4"	
AB612081	No.12	1"	AC612081
AB614061	No.14	3/4"	AC614061
AB614081	No.14	1"	AC614081

B = Pan Head

C = Countersunk Head

1st digit = thread type (coarse or fine)

2nd/3rd digit = diameter

4th/5th = length in 1/8" increments

6th = finish (1 = zinc plated)

Screws (Cross Slot) UNC

Pan Headed	Size	Length	Countersunk Headed
PMZ204	No.6	1/4"	CMZ204
PMZ208	No.6	1/2"	CMZ208
PMZ304	No.10	1/4"	CMZ304
PMZ305	No.10	5/16"	CMZ305
PMZ306	No.10	3/8"	CMZ306
PMZ307	No.10	7/16"	CMZ307
PMZ308	No.10	1/2"	CMZ308
PMZ310	No.10	5/8"	CMZ310
PMZ312	No.10	3/4"	CMZ312
PMZ314	No.10	7/8"	
PMZ316	No.10	1"	CMZ316
SE604041	1/4"	1/2"	SF604041
SE604051	1/4"	5/8"	SF604051
SE604061	1/4"	3/4"	SF604061
SE604071	1/4"	7/8"	SF604071
SE604081	1/4"	1"	SF604081
SE604121	1/4"	1 1/2"	SF604121
SE605061	5/16"	3/4"	SF605061
SE605081	5/16"	1"	SF605081

Nuts

Plain Nuts UNF

Full Nut	Thread Size	Spanner Size	Half Nut
HN2003	No.6	5/16"	
HN2005	3/16"	3/8"	
GHF206	3/16"	5/16"	
HN2007	1/4"	7/16"	NJ2107
HN2008	5/16"	1/2"	JN2108
HN2009	3/8"	9/16"	JN2109
HN2010	7/16"	5/8"	JN2110
HN2011	1/2"	3/4"	JN2111
HN2012	9/16"	7/8"	JN2112
HN2013	5/8"	15/16"	JN2113

Plain Nuts UNC

Full Nut	Thread Size	Spanner Size	Half Nut
HN2057	1/4"	7/16"	JN2157
HN2058	5/16"	1/2"	JN2158
HN2059	3/8"	9/16"	JN2159

Nyloc Self Locking Nuts UNF

Full Nut	Thread Size	Spanner Size	Half Nut
YN2905	3/16"	5/16"	
YN2907	1/4"	7/16"	GHF271
YN2908	5/16"	1/2"	TN3208
YN2909	3/8"	9/16"	TN3209
YN2910	7/16"	5/8"	TN3210
YN2911	1/2"	3/4"	TN3211
YN2912	9/16"	7/8"	TN3212
YN2913	5/8"	15/16"	TN3213

Self Locking, 'Aero' or all metal, 'Phillidas' Nuts UNF

Full Nut	Thread Size	Spanner Size	Half Nut
AN3507	1/4"	7/16"	
AN3508	5/16"	1/2"	
AN3509	3/8"	9/16"	
AN3510	7/16"	5/8"	
AN3511	1/2"	3/4"	

Slotted Nuts UNF

Full Nut	Thread Size	Spanner Size	Half Nut
ND606041	3/8"	9/16"	LN2209
ND607041	7/16"	5/8"	NL607041
ND608041	1/2"	3/4"	LN2211
ND609041	9/16"	7/8"	LN2212
ND610041	5/8"	15/16"	NL610041

Plain Brass - Manifold Nuts

Full Nut	Thread Size	Spanner Size
GHF261	5/16" UNF	1/2"
GHF262	3/8" UNF	9/16"
GHF270	5/16" UNC	1/2"
GHF269	3/8" UNC	9/16"

Spring/Spire Nut

Flat Type	Screw Size	'U' Type
GHF700	No.6	GHF711
GHF701	No.8	GHF712
GHF702	No.10	GHF713
GHF703	No.12	GHF714
GHF704	No.14	N/A

Captive Nuts

Captive nuts consist of a square nut & cage which we supply individually as required. Always match nut & cage A.F. sizes.

Part Number	Description	Thread Size
NQ2707	Nut, 7/16" AF	1/4"
NQ2708	Nut, 5/8" AF	5/16"
CN4	Nut, fits CN3 cage	1/4"

Shake-Proof Washers (Cont.)

WF702101	3/16"	WE702101
WF600041	1/4"	WE600041
WF600051	5/16"	WE600051
WF600061	3/8"	WE600061
WF600071	7/16"	WE600071
WF600081	1/2"	WE600081
WF600091	9/16"	WE600091
WF600101	5/8"	WE600101

Locking Washers - Spring Type

Single Coil	Hole Size	Double Coil
WL700061	No.6	
WL700081	No.8	
WL700101	3/16"	AJD7721
GHF331	1/4"	AJD7722
GHF332	5/16"	AJD7731
GHF333	3/8"	AJD7742
GHF334	7/16"	
GHF335	1/2"	
GHF336	5/8"	

Plain Washers

Standard Type	Hole Size	Repair Type
	No.6	WP3
	No.8	WP4
GHF306	3/16"	WP5
GHF300	1/4"	WP120
GHF301	5/16"	WP105
GHF302	3/8"	WP130
GHF303	7/16"	WM69
GHF304	1/2"	
	9/16"	WP12
	5/8"	PWZ110

Sealing Washers

Fibre Washer	Hole Size	Copper Washer
WF505	3/16"	
GHF342	1/4"	GHF361
GHF343	5/16"	GHF362
GHF344	3/8"	GHF363
GHF345	7/16"	GHF364
GHF346	1/2"	GHF365
GHF347	9/16"	
GHF348	5/8"	

Studs

A stud is a length of round bar threaded at both ends. The length of thread at each end of the stud may vary for specific applications. The following list is of studs have fine (UNF) threads at both ends.

Part Number	Diameter	Overall length
TE604081	1/4"	1"
TE604091	1/4"	1 1/8"
TE604101	1/4"	1 1/4"
TE605101	5/16"	1 1/4"
TE605111	5/16"	1 3/8"
TE605121	5/16"	1 1/2"
TE605131	5/16"	1 5/8"
TE605141	5/16"	1 3/4"
TE605151	5/16"	1 7/8"
TE605181	5/16"	2 1/4"
TE605201	5/16"	2 1/2"
TE605221	5/16"	2 3/4"
TE605251	5/16"	3 1/8"
TE605291	5/16"	3 5/8"
TE606101	3/8"	1 1/4"
TE606111	3/8"	1 3/8"
TE606121	3/8"	1 1/2"
TE606141	3/8"	1 3/4"
TE606151	3/8"	1 7/8"

Note: The following studs have fine (UNF) threads at one end and course (UNC) at the other.

Part Number	Diameter	Overall length
TE504081	1/4"	1"
TE504131	1/4"	1 5/8"
TE505091	5/16"	1 1/8"
TE505111	5/16"	1 3/8"
TE505121	5/16"	1 1/2"
TE505131	5/16"	1 5/8"
TE505141	5/16"	1 3/4"
TE505151	5/16"	1 7/8"
TE505161	5/16"	2"
TE505181	5/16"	2 1/4"
TE505201	5/16"	2 1/2"
TE505221	5/16"	2 3/4"
TE505241	5/16"	3"
TE505261	5/16"	3 1/4"
TE505271	5/16"	3 3/8"
TE505281	5/16"	3 1/2"
TE505341	5/16"	4 1/4"
TE506101	3/8"	1 5/16"
TE506131	3/8"	1 5/8"
TE506141	3/8"	1 3/4"
TE506161	3/8"	2"
TE506201	3/8"	2 1/2"
TE506361	3/8"	3 1/2"

Note: The following studs have course (UNC) threads at both ends.

Part Number	Diameter	Overall length
101442	3/8"	1 5/8"
058688	3/8"	1 11/16"
115696	3/8"	1 13/16"
058917	3/8"	1 15/16"
102474	3/8"	2 1/16"
107055	3/8"	2 3/8"

Dowels

Part Number	Diameter	Overall length
DP204	1/8"	1/4"
DP205	1/8"	5/16"
DP306	3/16"	3/8"
DP407	1/4"	7/16"
DP408	1/4"	1/2"
DP410	1/4"	5/8"
DP411	1/4"	11/16"
DP414	1/4"	7/8"
DP508	5/16"	1/2"
DP514	5/16"	7/8"
DP608	3/8"	1/2"
DP610	3/8"	5/8"
DP610	3/8"	1 3/16"

Clevis Pins

(Measured from under head to end)

Part Number	Length	Diameter
108326	1/2"	1/8"
PJ8504	3/8"	3/16"
CLZ307	7/16"	3/16"
CLZ308	1/2"	3/16"
CLZ309	9/16"	3/16"
CLZ310	5/8"	3/16"
CLZ311	11/16"	3/16"
CLZ312	3/4"	3/16"
CLZ313	13/16"	3/16"
CLZ314	7/8"	3/16"
CLZ315	15/16"	3/16"
CLZ316	1"	3/16"
CLZ317	1 1/16"	3/16"
	3/8"	1/4"
	7/16"	1/4"
CLZ408	1/2"	1/4"
CLZ409	9/16"	1/4"
CLZ410	5/8"	1/4"
CLZ411	11/16"	1/4"
CLZ412	3/4"	1/4"
CLZ413	13/16"	1/4"

Clevis Pins (Continued)

CLZ414	7/8"	1/4"
CLZ415	15/16"	1/4"
CLZ416	1"	1/4"
CLZ417	1 1/16"	1/4"
CLZ427	1 11/16"	1/4"
	1/2"	5/16"
	9/16"	5/16"
CLZ510	5/8"	5/16"
CLZ511	11/16"	5/16"
CLZ512	3/4"	5/16"
CLZ513	13/16"	5/16"
CLZ514	7/8"	5/16"
CLZ515	15/16"	5/16"
CLZ516	1"	5/16"
CLZ517	1 1/16"	5/16"
CLZ518	1 1/8"	5/16"

Split Pins

Part Number	Length	Diameter
GHF500	1 1/2"	1/16"
GHF501	1 1/2"	5/64"
GHF502	1 1/2"	3/32"
GHF503	2 1/4"	7/64"
GHF504	2 1/4"	1/8"
GHF505	2 1/4"	9/64"
GHF506	2 1/4"	5/32"
GHF513	4"	3/16"

Pipes, Hardware & Fittings

Brake & Fuel Pipe

Supplied in 25 foot rolls.

Part Number	Material	Diameter
MPKF125	Cupro-nickel	3/16"
MPKF225	Cupro-nickel	1/4"
MPKF325	Cupro-nickel	5/16"
EF125	Steel	3/16"
EF225	Steel	1/4"
EF325	Steel	5/16"

Pipe Nuts (Male, Steel)

Part Number	Thread Size	Pipe Bore
TM606031	3/8" UNF	3/16"
TM110051	10mm x 1mm	3/16"
LK21994	3/8" BSF	3/16"
BCA4370	7/16" UNF	1/4"
BHA4706	7/16" UNF	3/16"
AUSU40A	1/2" UNF	5/16"

Pipe Nuts (Male, Brass)

Part Number	Thread Size	Pipe Bore
AEHU1	3/8" UNF	3/16"
AEHU2	10mm x 1mm	3/16"
AEHU3	3/8" BSF	3/16"
AEHU7	7/16" UNF	3/16"

Pipe Nuts (Female, Steel)

Part Number	Thread Size	Pipe Bore
TN606031	3/8" UNF	3/16"
SU2A	10mm x 1mm	3/16"
SU4A	7/16" UNF	1/4"
HU41A	1/2" UNF	5/16"

Pipe Nuts (Female, Brass)

Part Number	Thread Size	Pipe Bore
AEHU1A	3/8" UNF	3/16"
AEHU2A	10mm x 1mm	3/16"
AEHU4A	7/16" UNF	1/4"

Bleed Screws

Part Number	Thread Size
556508A	3/8" UNF
608400A	10mm metric
27H7166	3/8" BSF

Pipe Clips

Part Number	Capacity
GHF1191	SINGLE, 3/16"
GHF1192	SINGLE, 1/4"
624155	DOUBLE, 3/16"
	DOUBLE, 1/4"

Grease Nipples

Part Number	Thread Size	Angle
UHN400	1/8" BSP	straight,
short		
UHN445	1/8" BSP	450 angle
LN30041	1/8" BSP	900 angle
144825	1/8" BSP	straight,
long		
056935	1/4" BSP	straight
125361	1/4" BSP	450 angle
056934	1/4" BSP	900 angle

Hose Clamps

Petrol Pipe Clips (Metric) ('Enots' type)

Part Number	to suit diameter
GGT1108X	8mm
GGT1109X	9mm
GGT1110X	10mm
GGT1111X	11mm
GGT1112X	12mm
GGT1113X	13mm
GGT1114X	14mm
GGT1115X	15mm
GGT1116X	16mm
GGT1117X	17mm

Hose Clips ('Jubilee' type)

Mild Steel (Imperial)

Part Number	to suit diameter
GHC304	3/8" - 1/2"
GHC405	7/16" - 5/8"
GHC406	1/2" - 3/4"
GHC507	5/8" - 7/8"
GHC608	3/4" - 1"
GHC10414	5/8" - 1 1/8"
GHC811	1" - 1 3/8"
GHC10415	1 1/8" - 1 5/8"
GHC1015	1 3/8" - 2"
GHC1217	1 1/2" - 2 1/4"
GHC10418	2" - 2 3/4"
GHC2228	2 3/4" - 3 1/2"
GHC2632	3 1/4" - 4"
GHC3036	3 3/4" - 4 1/2"
GHC3340	4 1/8" - 5"

Stainless Steel Hose Clips (Metric)

Part Number	to suit diameter
GHC10408	8 - 12 mm
GHC10410	12 - 18 mm
GHC10411	8 - 16 mm
GHC10412	12 - 20 mm
GHC10413	16 - 25 mm
GHC10414	20 - 32 mm
GHC10415	25 - 40 mm
GHC10416	32 - 50 mm
GHC10417	46 - 60 mm
GHC10418	50 - 70 mm
GHC10419	60 - 80 mm
GHC10420	70 - 90 mm
GHC10421	80 - 100 mm

For your notes...

A series of horizontal dashed lines intended for taking notes, spanning the width of the page.

What's in our free catalogues?

- Full colour accessory parts section, with colour images, £ prices and comprehensive information of each product, including interior, exterior and performance parts.

- Detailed annotated diagrams of vehicle components with comprehensive text listings detailing each part.

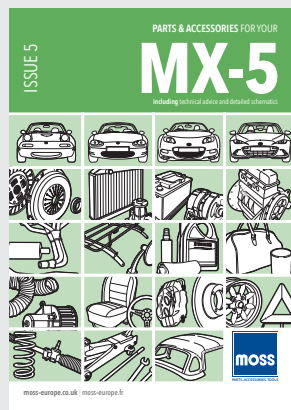
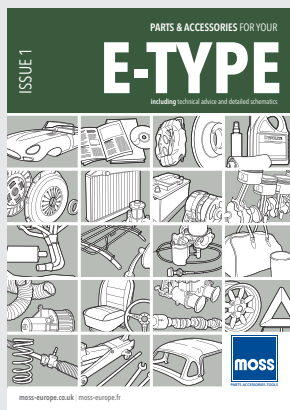
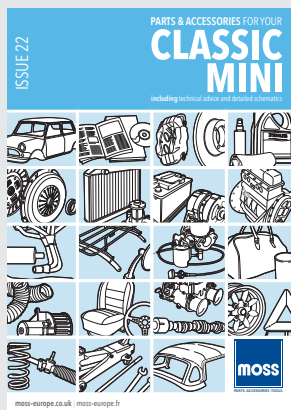
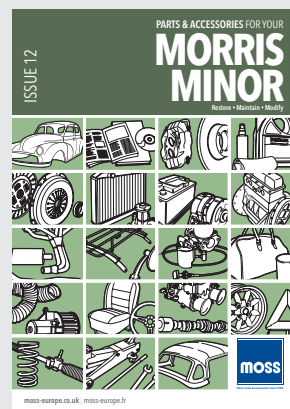
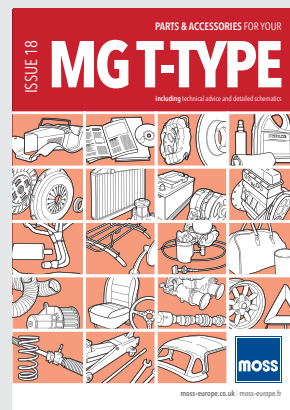
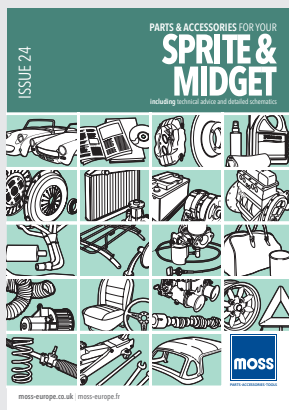
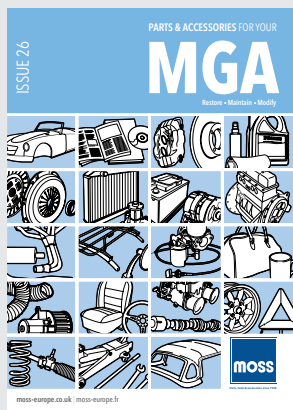

Our catalogues are absolutely free of charge, no matter where you are in the world, including delivery to UK, EU and the rest of the world. However, we will only pay the postal costs for one catalogue per customer. For online orders, your preferred catalogue must be 'added to basket' and an order placed in order for fulfilment. No payment details are required when placing this order. Moss reserve the right to refuse or withdraw an order at anytime should we consider that this offer is being unreasonably exploited.

DYNOLITE

EUROPE'S CLASSIC MOTOR OIL

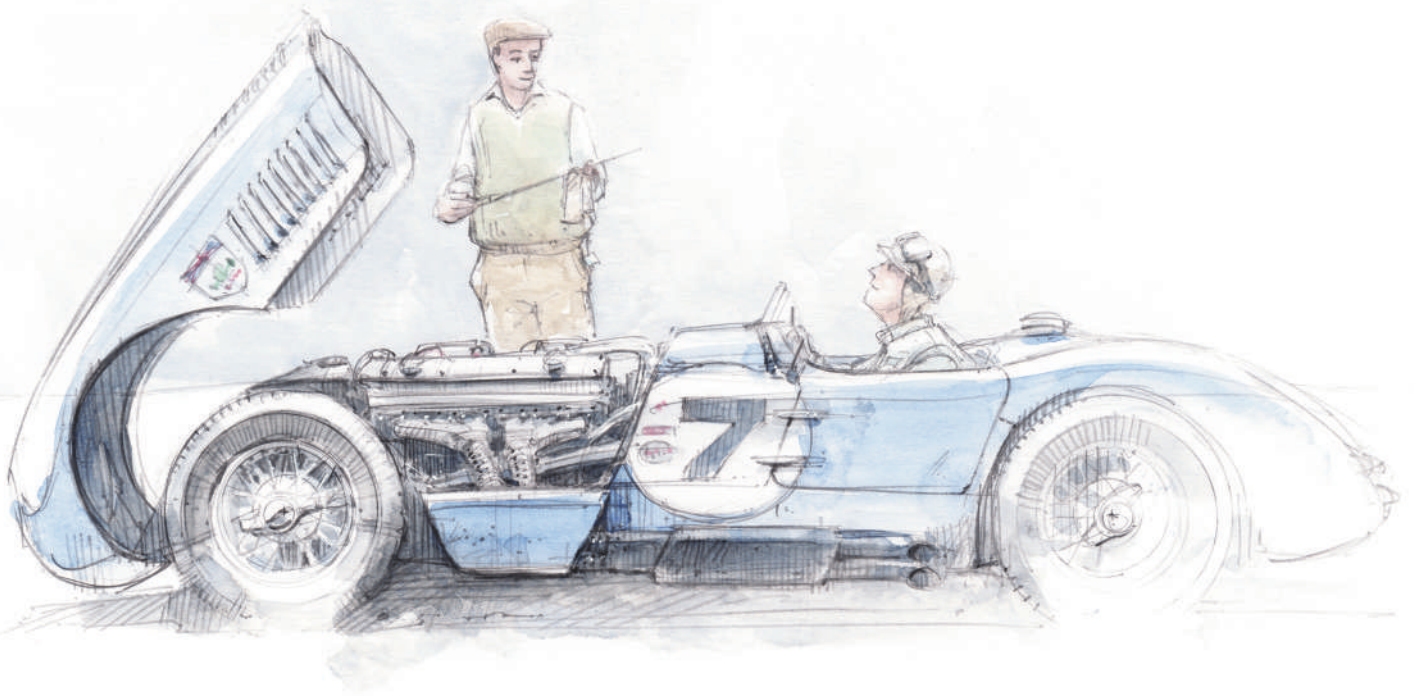

Dynolite Oil produces high quality oils and lubricants for vintage, classic and racing applications. Including lubricants for engines, gearboxes, steering boxes and greases. Dynolite lubricants are specially developed for historic vehicles to offer far superior mechanical protection.

Dynolite Stockist: Moss Europe Ltd.
www.dynolite.com



MOSS PARIS
7 rue Chaponval
Zac du Cornouiller
78870 Bailly, France

Paris Tel
+33 (0) 1 30 80 20 30

E-mail
sales@moss-europe.fr

[www Moss Websites](http://www.moss-websites.com)
moss-europe.eu | moss-europe.fr

 Facebook
facebook.com/mosseurope

 Instagram
instagram.com/mosseuropeltltd